

RES2DINVx64 ver. 4.08
with multi-core and 64-bit support

for Windows XP/Vista/7/8/10

Rapid 2-D Resistivity & IP inversion
using the least-squares method

Wenner (α, β, γ), dipole-dipole, inline pole-pole, pole-dipole, equatorial dipole-dipole, offset pole-dipole, Wenner-Schlumberger, gradient and non-conventional arrays
On land, aquatic, cross-borehole and time-lapse surveys

Geoelectrical Imaging 2-D & 3-D



GEOTOMO SOFTWARE SDN BHD

www.geotomosoft.com

May 2018

Geotomo Software Sdn Bhd

email : geotomosoft@outlook.com, support@aarhusgeosoftware.dk

Internet : www.geotomosoft.com

Notice of Copyright

RES2DINV is copyrighted by © M.H.Loke, 1995-2018. All rights reserved. No part of this document may be reproduced without written permission of Geotomo Software Sdn Bhd.

Table of Contents

Topic	Page No.
1 Introduction	1
2 Computer system requirements	2
3 Copy protection	3
4 Theory	4
5 Software installation	5
6 Using the program – a quick start	7
7 Data file format.....	8
7.1 Index based data format.....	8
7.1.1 Wenner, pole-pole, equatorial dipole-dipole arrays	8
7.1.2 Schlumberger, dipole-dipole and pole-dipole arrays.....	10
7.1.3 Topography data for index based format data files	12
7.2 General array data format	13
7.3 Remote electrodes of the pole-pole and pole-dipole arrays	18
7.4 Cross-borehole data format.....	21
7.5 I.P. data format.....	26
7.6 Time-lapse data files.....	29
7.7 Incorporating data noise estimates.....	30
7.8 Fixing resistivities	31
7.9 Aquatic surveys	32
7.9.1 Underwater surveys	33
7.9.2 Surveys with floating electrodes.....	37
7.10 Incorporating boundaries of known layers.....	39
7.10.1 Specifying and fixing resistivity of regions above and below a sharp boundary	41
7.11 Global or GPS coordinates	42
7.12 Extending the model horizontal range	45
8 File menu options	46
8.1 Read data file.....	46
8.2 Round up positions of electrodes	46
8.4 Cut-off factor to remove data.....	48
8.5 Calculate errors from repeated readings	48
8.6 Data Import	49
8.7 Collate data into RES3DINV format	49
8.8 Concatenate data into RES2DINV format	53
8.9 Combine 2-D files into a time-lapse file.....	54
8.10 Change buffer drive.....	55
8.11 Save sorted data after reading in data file	55
8.12 Trace program execution	55
9 Edit menu options	56
9.1 Exterminate bad data points.....	56
9.2 Splice large data sets	57
9.3 Trim large data set.....	58
9.4 Reverse pseudosection.....	59
9.5 Change location of first electrode	59
10 Change Settings menu options.....	60
10.1 Inversion Damping Parameters.....	60
10.1.1 Damping factors	60
10.1.2 Change of damping factor with depth	61
10.1.3 Limit range of model resistivity	61
10.1.4 Vertical to horizontal flatness filter ratio	62
10.1.5 Use diagonal filter	62
10.1.6 Use L-curve method to select damping factor	63
10.1.7 Reduce variations near boreholes	64
10.1.8 Use sensitivity values to damp variations near boreholes electrodes	65
10.2 Forward modeling settings	66
10.2.1 Horizontal mesh size	66
10.2.2 Vertical mesh size	67

10.2.3	Type of forward modeling method.....	67
10.2.4	Automatically adjust mesh grid size.....	67
10.3	Inversion progress settings	67
10.3.1	Line search local optimization.....	67
10.3.2	Convergence limit	67
10.3.3	Number of iterations.....	68
10.3.4	Model resistivity values check	68
10.4	Data/Display Selection	69
10.4.1	Option for contour intervals	69
10.4.2	Type of gradient array plot.....	69
10.5	Inversion parameters	72
10.5.1	Save inversion parameters.....	72
10.5.2	Read inversion parameters	72
11	Inversion menu options.....	73
11.1	Inversion options	73
11.2	Inversion Methods and Settings.....	74
11.2.1	Select robust inversion	74
11.2.2	Modify smoothness-constrained least-squares method.....	76
11.2.3	Choose logarithm of apparent resistivity	76
11.2.4	Type of method to solve least-squares equation	77
11.2.5	Use reference model in inversion	77
11.2.6	Fast inversion of long survey lines	78
11.2.7	Use fast Jacobian routines for dense data sets	79
11.2.8	Set time-lapse inversion settings	79
11.2.9	Floating electrodes survey inversion method	80
11.2.10	Limit water extent for underwater electrodes survey	82
11.2.11	Set DOI parameters	83
11.3	Model discretization	84
11.3.1	Display model blocks	84
11.3.2	Change thickness of layers	84
11.3.3	Modify depths to layers.....	85
11.3.4	Use extended model	86
11.3.5	Use model with blocks of same widths	86
11.3.6	Reduce effect of side blocks.....	86
11.3.7	Change width of blocks.....	87
11.3.8	Use model refinement	87
11.3.9	Set left and right limits of model.....	89
11.3.10	Type of cross-borehole model.....	89
11.4	Model Sensitivity Options	90
11.4.1	Display blocks sensitivity.....	90
11.4.2	Display subsurface sensitivity	90
11.4.3	Normalize sensitivity values.....	90
11.4.4	Generate model blocks	90
11.4.5	Calculate model resolution	90
11.5	I.P. Options.....	92
11.5.1	I.P. data and model weights.....	92
11.5.2	Cutoff for valid I.P. values	92
11.5.3	Change range of model I.P. values	93
11.5.4	Select type of I.P. transformation	93
11.5.5	Use I.P. model refinement.....	94
11.5.6	Type of I.P. smoothness constraint.....	94
11.5.7	Joint or separate of I.P. inversion	95
11.6	Batch mode options	96
11.6.1	Batch mode inversion.....	96
11.6.2	Save XYZ files in batch mode.....	96
11.7	Topography options.....	97
11.7.1	Display topography	97
11.7.2	Select type of trend removal.....	97

11.7.3	Type of topographic modeling	98
12	Print menu	100
13	Help menu	100
14	Displaying and exporting inversion model results	101
14.1	File menu options	101
14.1.1	Read file with inversion results	101
14.1.2	Read DOI pair of inversion files.....	101
14.1.3	Read second DOI inversion file.....	101
14.1.4	Model export.....	102
14.1.5	Trace program execution.....	102
14.2	Display sections menu options	103
14.2.1	Display data and model sections	103
14.2.2	Sensitivity displays.....	105
14.2.3	Time-lapse displays.....	107
14.2.4	Display region of investigation	109
14.3	Change display settings	109
14.3.1	Color settings	109
14.3.2	Display sections settings	110
14.3.3	Select fonts and units.....	113
14.4	Edit data	114
14.4.1	RMS error statistics.....	114
	Acknowledgements	116
	References	117
Appendix A	Array types in RES2DINV	120
Appendix B	Special OhmMapper Note	122
Appendix C	Converting data from the PASI instruments	123
Appendix D	Surveys with electrodes suspended in a water layer	125
Appendix E	Plotting with Surfer	127
Appendix F	Depth of investigation (DOI) calculations	132
	DISCLAIMER	133
	SUPPORT	133
	What's New.....	134

List of Figures

Figure 1. Sequence of measurements to build up a pseudosection using a computer controlled multi-electrode survey setup.	1
Figure 2. Two possible arrangements of the blocks used in a 2-D model together with the data points in the pseudosection.	2
Figure 3. Parameters that specify the location and length of an array in the index based data format.	8
Figure 4. Arrangement of electrodes for the equatorial dipole-dipole array.	8
Figure 5. Arrangement of the electrodes for the dipole-dipole and pole-dipole arrays. (a) Dipole-dipole array with integer 'n' factor. (b) Example of dipole-dipole array with non-integer "n" value. Arrangement of the electrodes for (c) the "forward" and (d) "reverse" pole-dipole arrays.	11
Figure 6. Arrangement of electrodes for the offset pole-dipole array.	12
Figure 7. Some possible non-conventional arrays. (a) Non-symmetrical four-electrode Wenner-Schlumberger or gradient type of array. (b) Dipole-dipole array with dipoles of unequal size. (c) A possible but probably non-viable electrode configuration. (d) Highly non-symmetrical dipole-dipole array.	13
Figure 8. Arrangement of the electrodes along a survey line such that the true horizontal distance between adjacent electrodes is constant regardless of the slope of the ground surface. Note that the distance between adjacent electrodes along the ground surface is greater at the steeper part of the slope.	17
Figure 9. A schematic diagram of the arrangement of the electrodes in an actual field pole-pole measurement.	18
Figure 10. A schematic diagram of the arrangement of the electrodes along the survey line in a pole-pole survey with positions of the C2 and P2 electrodes specified.	19
Figure 11. Arrangement of the electrodes in a cross-borehole survey. (a) The default standard model where the dimensions of the model blocks are equal to the spacing between the electrodes. (b) An alternative model with finer blocks with dimensions about half the spacing between the electrodes.	21
Figure 12. The model obtained after the inversion of the BOREHOLE.DAT data set. The option to use finer blocks with half the size of the spacing between the electrodes was used.	23
Figure 13. Model obtained from the inversion of data from a cross-borehole survey to map the flow of a saline tracer. Note the low resistivity zones near the surface (where the tracer was injected) and below a depth of 7 meters. The locations of the borehole electrodes are shown by small black dots.	23
Figure 14. Magusi River ore body resistivity and I.P sections. (a) Apparent resistivity pseudosection, (b) resistivity model section, (c) apparent metal factor pseudosection and (d) metal factor model section. ...	28
Figure 15. Fixing the resistivity of rectangular and triangular regions of the inversion model.	32
Figure 16. Five possible situations for aquatic surveys.	32
Figure 17. Hat Head land and underwater survey. (a) Apparent resistivity pseudosection (Wenner array) from the Hat Head tidal creek survey and (b) the inversion model. Note the creek between the 65 and 95 meters marks where the electrodes are underwater.	34
Figure 18. Lake Lelia underwater survey apparent resistivity pseudosection and model resistivity section. Courtesy of Technos Inc., USA.	34
Figure 19. Models for the Clifton survey from the different inversion methods are shown together. Note the boundary between the high resistivity sand layer and the underlying low resistivity clay layer is much better resolved in the blocky and sharp boundary inversion methods.	39
Figure 20. Example of a data set with a few bad data points. The data is displayed using the "Exterminate bad data points" option.	57
Figure 21. Example of a display using the splice data option for a data set in the indexed base format. ...	58
Figure 22. Types of roughness filters. (a) Horizontal and vertical components only. (b) Diagonal components as well.	62
Figure 23. Example L-curve plot to determine the optimum damping factor for the BLUERIDGE.DAT data set. (a) Variation of model roughness with data misfit for a range of spatial damping factor values (a few values are shown near the corresponding points), (b) variation of the curvature of the L-curve with the damping factor.	64
Figure 24. Schematic diagram of mesh and model cells used by forward modeling routine. This example has 4 nodes between adjacent electrodes.	66
Figure 25. Plot of a multiple gradient array data set in the form of profiles using exact pseudodepths for the CROMER2.DAT file.	70

Figure 26. Two different configurations of the gradient array with the same pseudodepth but with the potential electrodes at different sides of the array. Gradient array configuration with (a) right parity and (b) left parity.	70
Figure 27. Plot of a CROMER2.DAT multiple gradient array data set in the form of profiles using the approximate pseudodepth method.	71
Figure 28. The inversion result of the CROMER02.DAT data set with the apparent resistivity and model sections.	71
Figure 29. Example of inversion results using the smooth and robust inversion model constraint. (a) Apparent resistivity pseudosection. The inversion models produced by (b) the conventional least-squares smoothness-constrained method and (c) the robust or blocky inversion method.	75
Figure 30. Example of inversion model with a fixed water layer. The inversion results of the WATER_FLOAT.DAT data is shown where the resistivity water layer (represented by the top blue layer in the model section) is fixed and model extends from below the water bottom.	80
Figure 31. Arrangement of model blocks and the water bottom boundary for an arrangement with the water layer incorporated into the inversion model.	82
Figure 32. Inversion model for the survey with floating electrodes along the along the São Francisco River in Brazil. The thin black line indicates the water bottom boundary.	82
Figure 33. Different possible arrangement of model blocks for the same data set. (a) Using wider blocks at sides and bottom, (b) blocks of equal width, (c) model blocks extended to ends of survey line.	85
Figure 34. Example of inversion models using the standard and half-sized model blocks. (a) The apparent resistivity pseudosection for the PIPESCHL.DAT data set. The inversion models using (b) blocks with a width of 1.0 meter that is the same as the actual unit electrode, and (c) using narrower blocks with a width of 0.5 meter.	89
Figure 35. Two arrangements of model blocks using the extended model and sensitivity values methods. The arrangement of the model blocks used by the program for the inversion of the MIXEDWS.DAT data set using (a) the default extended model and (b) a model generated so that any single block the does not have a relative sensitivity value that is too small.	91
Figure 36. Topography linear trend removal for the Rathcrogan mound data set.	97
Figure 37. Example of the model for the Rathcrogan Mound data set. (a) Measured apparent resistivity pseudosection. (b) Inverse model section with topography.	98
Figure 38. Different methods to incorporate topography into a 2-D inversion model. (a) Schematic diagram of a typical 2-D inversion model with no topography. Model mesh discretization with a distorted grid to match the actual topography where (b) the subsurface nodes are shifted vertically by the same amount as the surface nodes, (c) the shift in the subsurface nodes are gradually reduced with depth or (d) rapidly reduced with depth, and (e) the model obtained with the inverse Schwartz-Christoffel transformation method.	99
Figure 39. Model resolution sections for the LANDFIL.DAT data set. (a) Apparent resistivity pseudosection. (b) Inversion model section. (c) Model resolution section. (d) The model resolution normalized by the cross-section area of the model block. (e) The model resolution index (after normalization by model block area) section.	106
Figure 40. Apparent resistivity and inversion model sections from the Birmingham time-lapse experiment. (a) The apparent resistivity and (b) inversion model sections from the survey conducted at the beginning of the Birmingham infiltration study. The data and model after 10 hours of irrigation are shown in (c) and (d).	108
Figure 41. Sections showing the change in the subsurface resistivity values with time obtained from the inversion of the data sets collected during the infiltration and recovery phases of the study.	108
Figure 42. Example of underwater survey. (a) Apparent resistivity pseudosection. (b) Model section with topography. Note the contoured model plot has been extended upwards to the water bottom interface, and the color of the water layer matches the contour scale used for the resistivity sections. This example is from an underwater riverbed survey by Sage Engineering, Belgium.	111
Figure 43. Histogram and scatter plots for the inversion results of the (a) RATHCRO.DAT and (b) IPMAGUSI.DAT data sets.	115
Figure 44. Arrangement of the electrodes for some commonly used arrays and their geometric factors.	120
Figure 45. Normal, reverse and offset pole-dipole array arrangements.	121
Figure 46. Example OhmMapper data set and inversion model. (a) Apparent resistivity pseudosection measured with an OhmMapper mobile resistivity surveying system. (b) Model section obtained by RES2DINV program.	122
Figure 47. Mesh used to model water layer.	125

Figure 48. Example data set and inversion model for a survey with a streamer suspended in a water layer. (a) Apparent resistivity pseudosection and (b) inversion model section.	125
Figure 49. Example display with topography for the RATCHRO.INV file.	127
Figure 50. Plot of the RATCHRO.INV file output using Surfer.	131
Figure 51. Example DOI plot for the beta.dat file.	132

List of Tables

Table 1. Partial list of files installed with the RES2DINVx64 program.	5
Table 2. Example Wenner array data file format.	9
Table 3. Example equatorial dipole-dipole array data file.	9
Table 4. Example Wenner-Schlumberger array data file.	10
Table 5. Example dipole-dipole array data file.	10
Table 6. Example pole-dipole array data file.	11
Table 7. Example offset pole-dipole array data file.	12
Table 8. Example of index based data file with topography.	13
Table 9. Example data file with general array format.	14
Table 10. Example general array format file with topography.	15
Table 11. Example general array data format file with topography in a separate section.	15
Table 12. Example gradient array data file.	18
Table 13. Pole-pole data file with remote electrodes specified.	20
Table 14. Example borehole data set.	24
Table 15. Example data set with inclined boreholes.	25
Table 16. Example borehole data set with topography.	26
Table 17. Example data file with I.P. values as chargeability.	27
Table 18. Example time-lapse data set with 3 time series.	29
Table 19. Example data file with noise estimates.	30
Table 20. Example data file with fixed regions.	31
Table 21. Example data file for aquatic survey with bottom electrodes.	33
Table 22. Underwater survey data file in general array format.	35
Table 23. Survey across a dam with only electrodes on the dam side underwater.	36
Table 24. Underwater survey data file with two water layers.	37
Table 25. Survey data file with floating electrodes.	38
Table 26. Example survey data file with known boundaries.	40
Table 27. Example data file with sharp boundary and specified resistivity of regions above and below boundary.	41
Table 28. Example data file with global coordinates.	42
Table 29. Example data file with index based format and topography and global coordinates.	43
Table 30. Example data file with general array format, topography and global coordinates.	43
Table 31. Example aquatic survey data file with global coordinates.	44
Table 32. Example data file with extended model range.	45
Table 33. Example script file to combine 2-D data files into a 3-D data file.	50
Table 34. Example script file to combine data from 2-D lines in different directions into a 3-D data file.	51
Table 35. Example data file with global coordinates for an array with offline electrodes.	52
Table 36. Example script file to concatenate 2-D data files.	53
Table 37. Example script file to combine 2-D data files into a time-lapse file.	54
Table 38. Data file with standard unit electrode spacing.	88
Table 39. Data file with half the standard unit electrode spacing.	88
Table 40. Array types and their number codes.	120
Table 41. Example data file for a survey electrodes suspended in a water layer.	126

1 Introduction

RES2DINVx64 is a computer program that will automatically determine a two-dimensional (2-D) resistivity model for the subsurface for data obtained from 2-D electrical imaging surveys (Dahlin 1996). It is a 64-bit Windows based program that supports multi-core CPUs.

Figure 1 shows an example of the electrodes arrangement and measurement sequence that can be used for a 2-D electrical imaging survey. Many different multi-electrode systems have been developed over the past 20 years using different arrangements of the cables and measurement strategies (Loke 2018, Loke et al. 2013). This program is designed to invert large data sets (with about 200 to 100000 data points) collected with a system with a large number (25 to 16000) of electrode positions along the survey line. The survey is usually carried out with a system where the electrodes are arranged along a line with a constant spacing between adjacent electrodes. However, the program can also handle data sets with a non-uniform electrode spacing.

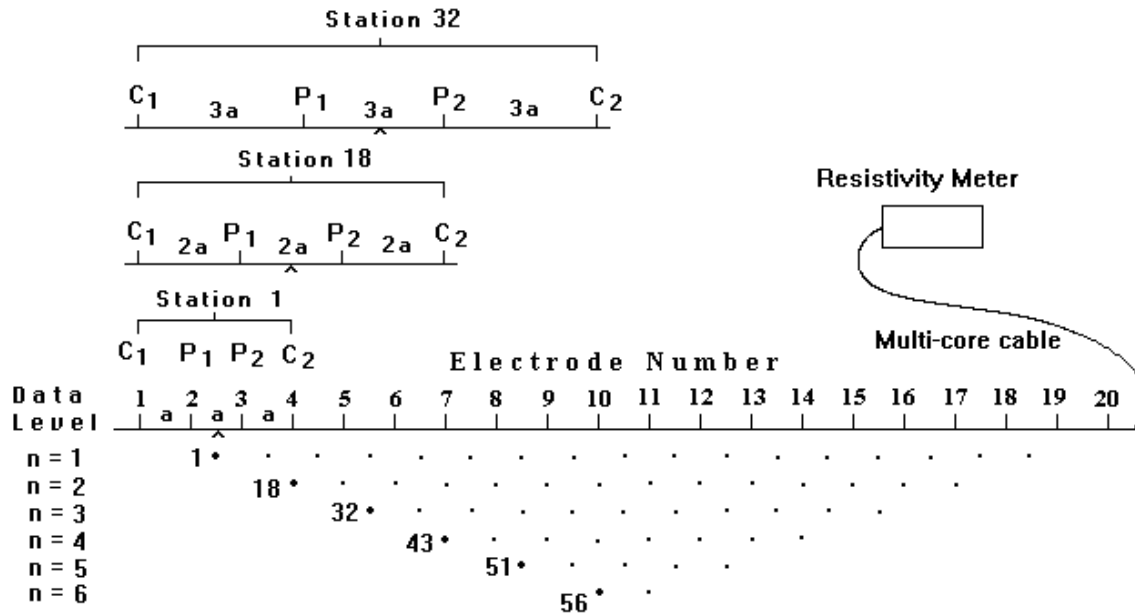

Sequence of measurements to build up a pseudosection

Figure 1. Sequence of measurements to build up a pseudosection using a computer controlled multi-electrode survey setup.

The 2-D model used by the inversion program consists of a large number of rectangular blocks. Figure 2a shows an arrangement of the blocks that is loosely tied to the distribution of the data points in the pseudosection. The distribution and size of the blocks are automatically generated by the program using the distribution of the data points as a rough guide. The depth of the bottom row of blocks is set to be approximately equal to the median depth of investigation (Edwards 1977) of the data points with the largest electrode spacing. Figure 2b shows an alternative arrangement with blocks of uniform width extending to the ends of the survey line.

A finite-difference or finite-element modelling subroutine is used to calculate the apparent resistivity values, and a non-linear smoothness-constrained least-squares optimization technique is used to calculate the resistivity of the model blocks (deGroot-Hedlin and Constable 1990). This program can be used for surveys using the Wenner, pole-pole, dipole-dipole, pole-dipole, Wenner-Schlumberger, gradient and equatorial dipole-dipole (rectangular) arrays (Appendix A). In addition to these common arrays, the program supports non-conventional arrays with an almost unlimited number of possible electrode configurations (Loke et al. 2010a,b). You can process pseudosections with up to 16000 electrode positions and 100000 data points at a single time on a computer with 8 gigabytes (GB) of RAM. Besides normal surveys carried out with the electrodes on the ground surface, the program also supports aquatic and cross-borehole surveys.

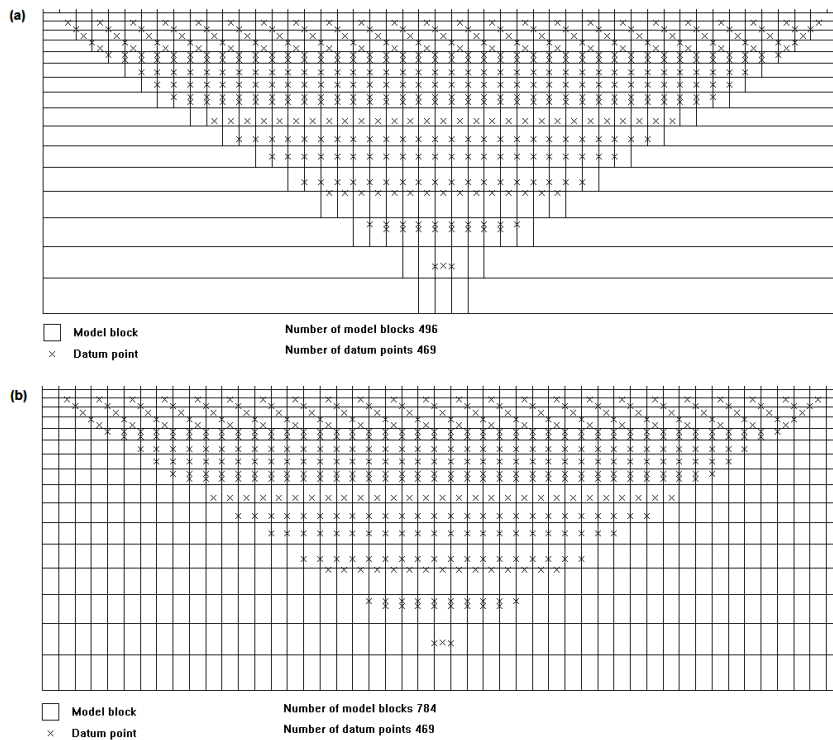

Figure 2. Two possible arrangements of the blocks used in a 2-D model together with the data points in the pseudosection.

2 Computer system requirements

This program is designed to run on microcomputers using the Windows XP/Vista/7/8/10 operating systems. On a modern multi-core PC, it will take less than a half a minute to invert the data set obtained from a survey with 100 electrodes.

System requirements : A PC with a 64-bit multi-core CPU, at least 4 GB RAM and a 64-bit version of Windows is required. However, it is recommended that you use a PC with at least 8 GB RAM. The program can access more than 8 GB RAM. This greatly increases the data and model size that can be processed.

It is recommended that you use a PC with an Intel (rather than an AMD) CPU as the RES2DINVx64 program is optimized for this type of CPU. These optimizations can significantly reduce the calculation time for large data sets. The program uses the hard-disk to store temporary swap files. If you have more than one hard-disk drive, the program will automatically select the drive with the largest amount of free space as the drive to store the swap files. The amount of free hard-disk space should be at least 4 times the RAM.

Practically all computers have an in-built power management system that slows down and eventually shuts down the computer system if the keyboard or mouse is not accessed after a certain time limit. This can interfere with the operation of the RES2DINVx64 program if you are inverting a large data set or using the batch mode to invert a large number of data files. Windows also has an in-built screen saver functions that replaces the contents of the screen with a screen saver program. Before running the RES2DINVx64 program, you will need to disable both the power management and screen saver programs.

There should not be too many background programs running while executing this program. The active background programs are usually shown on the 'Start' bar at the bottom of the screen. By shutting down the other programs, more memory will be available to this program. This will reduce memory to hard-disk swapping that slows down the program.

3 Copy protection

The program uses the Aarhus Geosoftware Internet based digital copy protections system for copy protection. Without the digital license, you can use the program to invert data sets with up to 84 electrodes (with a limit of 4 iterations in the inversion routine). With a license that has the RES2DINVx64 software license, the restrictions are removed. When the program is launched for the first time the user is prompted to supply a license code:

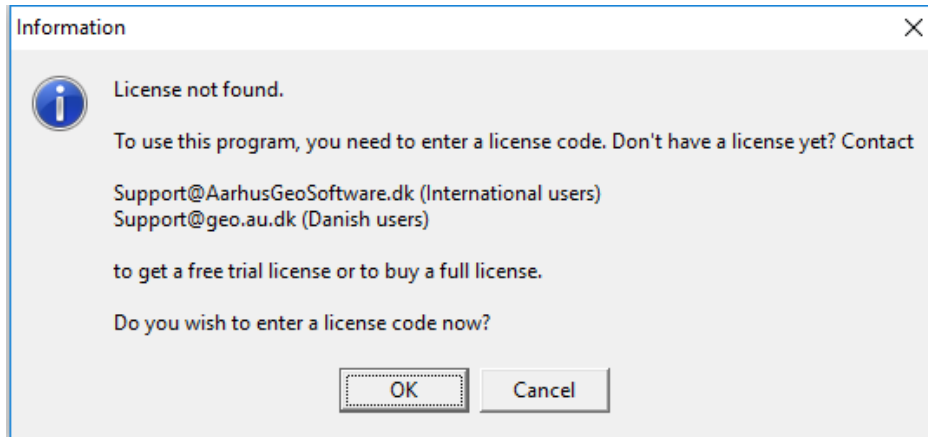

If “Cancel” is selected the program continues in demo mode with limited functionality. If “OK” is selected the user need to enter the license code in the following window and press “OK”.

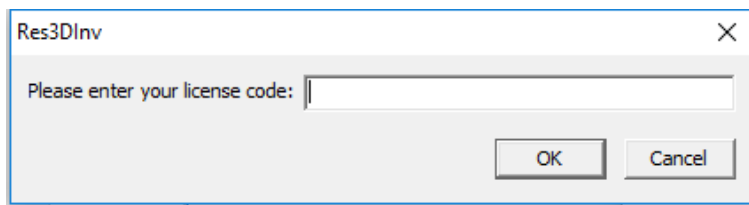

If the license code is valid the following screen with information about the PC and the license is seen:

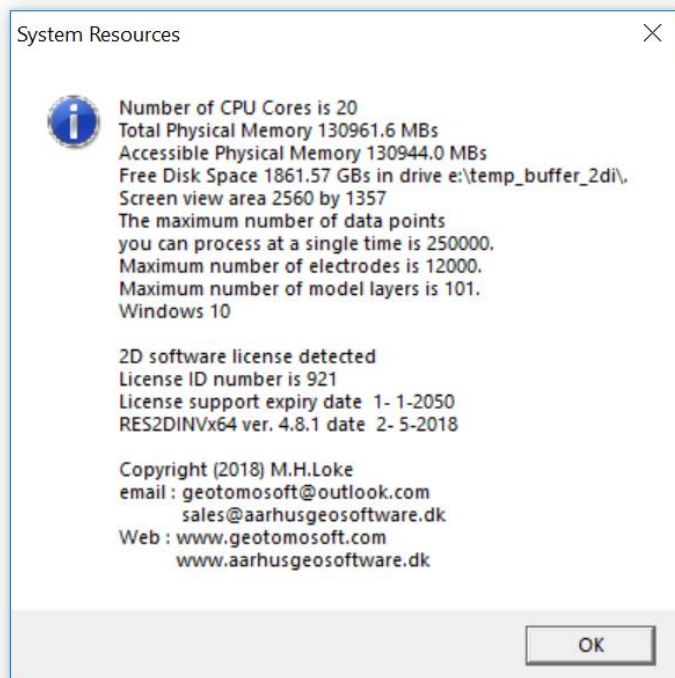

It is also possible to see the license information in ‘Help -> show AGS license file’ menu option.

The license can be unregistered to be moved to another PC, always remember to do this before unregistering the software as the computer will still take up the license if this is not done.

To unregister the license press 'Help → Unregister AGS license' option as shown below:



4 Theory

The inversion routine used by the program is based on the smoothness-constrained least-squares method (deGroot-Hedlin and Constable 1990, Sasaki 1992, Loke et al. 2003). The smoothness-constrained least-squares method is based on the following equation

$$(\mathbf{J}^T \mathbf{J} + \lambda \mathbf{F}) \Delta \mathbf{q}_k = \mathbf{J}^T \mathbf{g} - \lambda \mathbf{F} \mathbf{q}_k, \quad (4.1)$$

where

$$\mathbf{F} = \alpha_x \mathbf{C}_x^T \mathbf{C}_x + \alpha_z \mathbf{C}_z^T \mathbf{C}_z,$$

\mathbf{C}_x = horizontal roughness filters, \mathbf{C}_z = vertical roughness filter

\mathbf{J} = Jacobian matrix of partial derivatives, \mathbf{J}^T = transpose of \mathbf{J}

λ = damping factor, \mathbf{q} = model change vector, \mathbf{g} = data misfit vector

One advantage of this method is that the damping factor and roughness filters can be adjusted to suit different types of data. A detailed description of the different variations of the smoothness-constrained least-squares method can be found in the free tutorial notes by Loke (2018). The different program options are described in sections 10 and 11.

The optimization method tries to reduce the difference between the calculated and measured apparent resistivity values by adjusting the resistivity of the model blocks subject to the smoothness constraints used. A measure of this difference is given by the root-mean-squared (RMS) error. However, the model with the lowest possible RMS error sometimes show large and unrealistic variations in the model resistivity values and might not always be the "best" model from a geological perspective. In general, the most prudent approach is to choose the model at the iteration after which the RMS error does not change significantly. This usually occurs between the 3rd and 6th iterations.

5 Software installation

You can download the programs from the www.aarhusgeosoft.dk website. The RES3DINVx64 package comes in a single compressed installation file SETUP.EXE. It is a Windows-based installation program that will install the program files. The default folder for the program is C:\Program Files (x86)\Geotomo_Software\Res3dinvx64. Table 1 shows a list of some of the files that are installed when you run the SETUP.EXE program.

Table 1. Partial list of files installed with the RES2DINVx64 program.

RES2DINVx64.EXE	Main inversion program
RES2DINVx64_INTEL.EXE	Version of program optimized for recent Intel CPUs
RES2DINVx64.PDF	Manual in PDF format
RES2DINV.CHM	Windows Help file for this program
REGISTER.TXT	Registration file in text format
REGISTER.DOC	Registration file in MS Word format
LANDFILL.DAT	An example field data file for the Wenner array obtained by a survey with 50 electrodes. This example shows an interesting application of 2-D electrical imaging to map a pollution plume from a landfill site (Niederleithinger, 1994).
GRUNDFOR.DAT	Another field example for the Wenner array, but with a more irregular distribution of the data points.
ODARSLOV.DAT	A fairly large data set collected over a high resistivity dyke (Wenner array).
ROMO.DAT	Another fairly large data set (Wenner array).
DUFUYA.DAT	This is a large data set with nearly 300 electrodes and more than 1200 data points (Wenner array).
GLADOE2.DAT	An example data file with topographical information.
BLOCKWEN.DAT	Input test data file for Wenner array with a few bad data points.
BLOCKDIP.DAT	Example input data file for dipole-dipole array.
BLOCKTWO.DAT	Example input data file for pole-pole array.
RATHCRO.DAT	Wenner array data file from an archaeological survey which also contains topographical information.
RATHCRO.INV	Example inversion file.
RATHCRO_SURFER.ZIP	Example Surfer files.
RATCMIX.DAT	Same data set as above but in general array format.
RATCMIX_Sep_Topo.DAT	Same data set as above in general array format but with the topography section listed after the main data section.
RATCMIX_Global.dat	Example data set in general array format and global coordinates.
PIPESCHL.DAT	Example field data set for the Wenner-Schlumberger array.
WATER.DAT	Example data file for an underwater survey.
LAKELELIA.DAT	Example of an underwater field survey data set.
MODEL101.DAT	A moderately large test data set.
DIPOLEN5.DAT	Example dipole-dipole data file with non-integer values for the “ <i>n</i> ” factor.
BLUERIDGE.DAT	Example dipole-dipole data set with different “ <i>a</i> ” and “ <i>n</i> ” combinations.
WENSCHN5.DAT	Example Wenner-Schlumberger data set with non-integer values for the “ <i>n</i> ” factor.
PDIPREV.DAT	Example pole-dipole data file with the "forward" and "reverse" arrangement of the electrodes.
POLDPIN5.DAT	Example pole-dipole data set with non-integer values for the “ <i>n</i> ” factor.
OHMMAPPER.DAT	Example field data set from a mobile surveying system
IPMODEL.DAT	IP with data set with chargeability values
IPSHAN.DAT	Field survey IP data set with PFE values
IPMAGUSI.DAT	Field survey IP data set with metal factor values.

IPKENN.DAT	Field survey IP data set with phase angle values
BOREHOLE.DAT	Example cross-borehole data set.
BOREHIP.DAT	Example cross-borehole data set with IP measurements.
BORELANC.DAT	Cross-borehole field data set.
BOREDIFF.DAT	Example cross-borehole data set where the electrodes in the two borehole are not at the same depths.
BORERES.DAT	Example cross-borehole data set with measurements given as resistance values.
BOREHOLE_Global.dat	Example borehole data set with global coordinates.
BOREHOLE_TOPO.DAT	Example borehole data set with topography
TIMELAPS.DAT	Example time-lapse data set.
MIXED.DAT	Example data set in general array format with mixture of measurements with Wenner-Schlumberger and dipole-dipole arrays.
CROMER02.DAT	Gradient array data set.
LONG_RES.DAT	A synthetic resistivity data set with 600 electrodes (Wenner Alpha array).
LONG_IP.DAT	Long data set with I.P. values as well (Wenner Beta array).
HAT_HEAD.DAT	Example of a survey across a river with underwater electrodes.
DAM_SURVEY.DAT	Example data set of a survey across a dam with only electrodes in the dam underwater.
Suspended-Streamer-Aquatic-Survey.dat	Example data file with a suspended streamer in underwater survey.
COLLATE_2D_TO_3D-Arbitrary.zip	This contains a set of example files to collate data 2-D survey lines into the arbitrary electrodes format 3-D data file used by the RES3DINVx64 program.
RES2DINV.INI	Configuration file for the RES2DINVx64 program.
RES2DINV.IN2	Alternative configuration file.
README.TXT	Latest information about the current version of the 2-D inversion program.
RESIS.BTH	Example file for the batch processing mode option

The RES2DINVx64_INTEL.EXE program should only be used in PCs with the Intel Sandy Bridge, Ivy Bridge, Broadwell, Skylake and Kabylake CPUs.

6 Using the program – a quick start

Click the RES2DINVx64 icon to start the program. The program will first check the computer system to ensure that it has the necessary resources (such as memory and hard-disk space) that it requires. As an example, below is a typical initial information box displayed by the program.

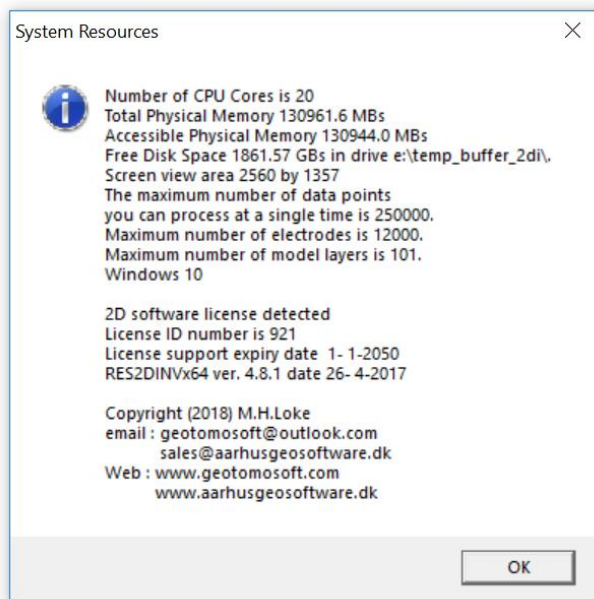

After checking the computer configuration, the program will then display the following Main Menu bar near the top of the screen.

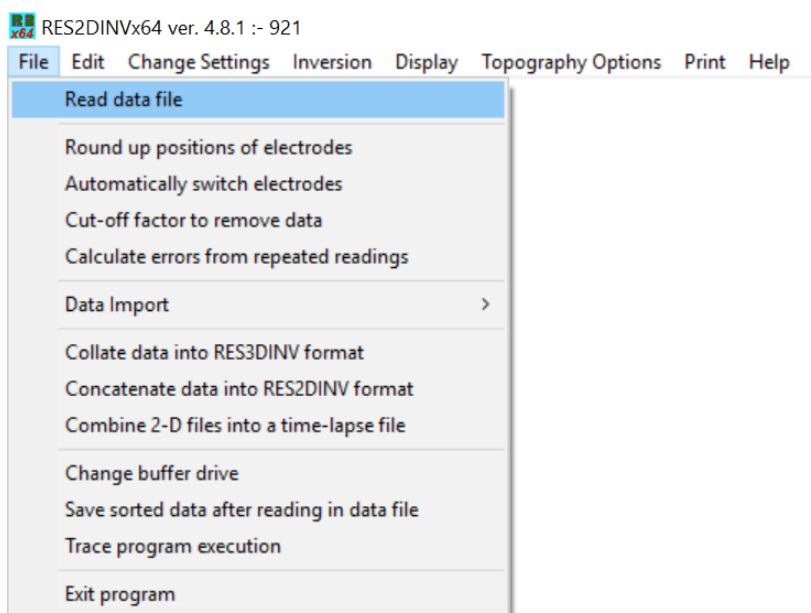

You can select an option by clicking it with the mouse cursor. If this is the first time you are using the program, try reading in one of the smaller files such as the BLOCKDIP.DAT provided with the program. Click the "File" choice, followed by the "Read data file" menu choice. After that, if necessary, navigate to the folder where the RES2DINV program is installed. After reading in the file, go to the "Inversion" option, and then choose the "Carry out inversion" option. The inversion subroutine will start. Wait for about a second for the data to be inverted. If you need to stop the inversion routine at any time, just click the 'Next' sub-window at the bottom-right of the screen and wait for a short while. By default, the program will carry out 6 iterations that can be increased if necessary.

After the inversion process has been completed, click the "Display" option that will open up a new window. In the new window, click the "Display sections - Display data and model sections" sub-option. You will then be asked to select the iteration number and type of contour intervals. After you have made the appropriate choices, the program will then display the apparent resistivity and inversion model sections.

7 Data file format

When you select the “**Read data file**” menu choice as described in the previous section, a list of files in the current folder that has an extension of DAT will be displayed. It is assumed that the files follow the format required by this program. If not, you have to convert the raw data file using the conversion program for the particular resistivity meter system. Most field equipment systems, such as the Abem and Iris Instrument systems, come with a utility program to convert the raw data into the format required by the RES2DINVx64 program. This program can also import data from a number of field systems (section 8.6). The apparent resistivity values are given in a text file. You can use any text editor, such as the Windows Notepad program, if you are creating the data file manually. The data are arranged in an ASCII delimited manner where a comma or blank space or LF/CR is used to separate different numerical data items. If there is a problem in running this program, one possible cause is that the input data were arranged in a wrong format.

There are two main types of data format used by this program, an index based and a general array format. The older index based format is only used for conventional arrays such as the Wenner, Wenner-Schlumberger, pole-pole, pole-dipole and dipole-dipole arrays. The general array format can be used for any array, including non-conventional arrays.

7.1 Index based data format

The index based data format use a maximum of three parameters to specify an array (Figure 3). The first parameter is the location of the first (leftmost) electrode or the mid-point of the array. The second parameter is the spacing between the P1 and P2 potential electrodes (the 'a' spacing). The third parameter (only applicable to the pole-dipole, dipole-dipole and Wenner-Schlumberger arrays) is the ratio of the distance of the current electrode from the nearest potential electrode to the P1-P2 spacing (the 'n' value). The three parameters are illustrated in Figure 3 for the dipole-dipole array as an example.

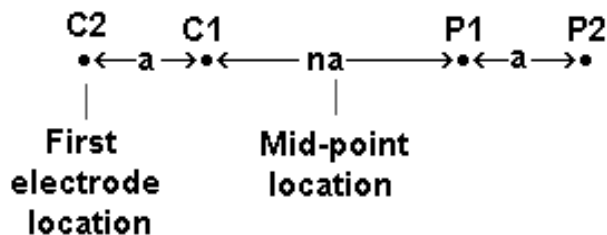

Figure 3. Parameters that specify the location and length of an array in the index based data format.

7.1.1 Wenner, pole-pole, equatorial dipole-dipole arrays

For the Wenner, pole-pole and equatorial dipole-dipole arrays (see **Error! Reference source not found.**), it is always assumed that the 'n' factor is always equals to 1 and thus need not be listed in the data file. As an example of a data file without the 'n' factor, Table 2 shows the data format for the example file LANDFILL.DAT with comments about information in the data lines.

The data file BLOCKPOL.DAT gives an example of a pole-pole array data set. The arrangement of the electrodes for the equatorial dipole-dipole array is shown in the Figure 4.

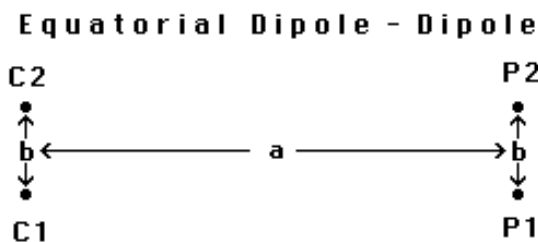

Figure 4. Arrangement of electrodes for the equatorial dipole-dipole array.

Table 2. Example Wenner array data file format.

<i>LANDFILL.DAT file</i>	<i>Comments</i>
LANDFILL SURVEY	<i>Name of survey line</i>
3.0	<i>Unit electrode spacing</i>
1	<i>Array type, 1 for Wenner</i>
334	<i>Number of data points</i>
1	<i>Type of x-location for data points, 1 for mid-point</i>
0	<i>Flag for I.P. data, 0 for none (1 if present)</i>
4.50 3.0 84.9	<i>First data point. For each data point, list the x-location,</i>
7.50 3.0 62.8	<i>'a' electrode spacing, apparent resistivity value</i>
10.50 3.0 49.2	<i>Third data point</i>
13.50 3.0 41.3	<i>Fourth data point</i>
...	<i>Same format for other data points</i>
...	
75.00 48.0 52.5	<i>Last data point</i>
0,0,0,0	<i>Ends with a few zeros. Flags for other options.</i>

The apparent resistivity value ρ_a for this array is given by

$$\rho_a = \frac{2\pi a s}{(s-a)} R \quad (7.1)$$

where $s = (a^2 + b^2)^{0.5}$ and R is the measured resistance. This array differs from other arrays where the electrodes are arranged in a single line. Each reading is characterized by two spacings. The first spacing, a , is the distance between the current electrodes pair C1-C1 and the potential pair P1-P2. The second spacing, b , is the spacing between the C1 and C2 electrodes. This program has a restriction that the spacing between the P1-P2 pair must be the same as that between the C1-C2 pair. An example of a data file for this array is the data file FAULTEQU.DAT in Table 3. For this array, it is necessary to include the 'b' spacing between the C1-C2 electrodes pair after the array number. It is assumed all the readings in the data file use the same 'b' spacing. If different 'b' spacings are used, please refer to Appendix B in the Res3dinvx64 manual.

Table 3. Example equatorial dipole-dipole array data file.

<i>FAULTEQU.DAT file</i>	<i>Comments</i>
Equatorial dipole-dipole array	<i>Name of survey line</i>
1.0	<i>Unit electrode spacing (a)</i>
8	<i>Array type, 8 for equatorial dipole-dipole</i>
1.5	<i>The 'b' spacing between the C1-C2 pair</i>
285	<i>Number of data points</i>
1	<i>Type of x-location for data points, 1 for mid-point</i>
0	<i>Flag for I.P. data, 0 for none (1 if present)</i>
0.50 1.00 2.74	<i>First data point. For each data point, list the</i>
1.50 1.00 2.74	<i>x-location, 'a' electrode spacing, and the</i>
...	<i>apparent resistivity value</i>
...	
..	<i>Same format for other data points</i>
..	
47.00 6.00 1.02	<i>Last data point</i>
0,0,0,0	<i>Ends with a few zeros. Flags for other options.</i>

7.1.2 Schlumberger, dipole-dipole and pole-dipole arrays

The dipole-dipole, pole-dipole and Wenner-Schlumberger arrays (**Error! Reference source not found.**) data sets have a slightly different format since an extra parameter, the dipole separation factor ' n ', is needed. Table 4 shows an example for the Wenner-Schlumberger array.

Table 4. Example Wenner-Schlumberger array data file.

<i>PIPESCHL.DAT file</i>	<i>Comments</i>
Underground pipe survey	<i>Name of survey line</i>
1.0	<i>Unit electrode spacing</i>
7	<i>Array type, 7 for Wenner-Schlumberger</i>
173	<i>Number of data points</i>
1	<i>Type of x-location for data points, 1 for mid-point</i>
0	<i>Flag for I.P. data, 0 for none (1 if present)</i>
1.50 1.00 1 641.1633	<i>First data point. For each data point, list the x-location,</i>
2.50 1.00 1 408.0756	<i>'a' electrode spacing, the 'n' factor and the</i>
3.50 1.00 1 770.0323	<i>apparent resistivity value</i>
4.50 1.00 1 675.3062	<i>Fourth data point</i>
...	
..	<i>Same format for other data points</i>
..	
2.50 1.00 2 206.2745	<i>31st data point, note 'n' value of 2</i>
...	
19.00 2.00 5 896.3058	<i>Last data point, note a=2.0 and n=5</i>
0,0,0,0	<i>Ends with a few zeros. Flags for other options.</i>

Table 5 describes the data file format for the dipole-dipole array.

Table 5. Example dipole-dipole array data file.

<i>BLOCKDIP.DAT file</i>	<i>Comments</i>
Block	<i>Name of survey line</i>
1.0	<i>Unit electrode spacing</i>
3	<i>Array type, 3 for dipole-dipole</i>
173	<i>Number of data points</i>
1	<i>Type of x-location for data points, 1 for mid-point</i>
0	<i>Flag for I.P. data, 0 for none (1 if present)</i>
1.50 1.00 1 641.1633	<i>First data point. For each data point, list the x-location,</i>
2.50 1.00 1 408.0756	<i>'a' electrode spacing, the 'n' factor and the</i>
3.50 1.00 1 770.0323	<i>apparent resistivity value</i>
...	
..	<i>Same format for other data points</i>
..	
2.50 1.00 2 206.2745	<i>31st data point, note 'n' value of 2</i>
...	
19.00 2.00 5 896.3058	<i>Last data point, note a=2.0 and n=5</i>
0,0,0,0	<i>Ends with a few zeros. Flags for other options.</i>

In most cases, the ' n ' dipole separation factor is an integer value. However, it is possible for the ' n ' factor to have non-integer values although all the electrodes still have a constant inter-electrode spacing. This can occur when the spacing ' a ' between the P1-P2 pair is twice (or more) the unit electrode spacing. For the example shown in Figure 5b, the unit electrode spacing for the survey line is 1 meter. The ' a ' spacing has a value of 2 meters, while the distance between the C1 and P1 electrodes is 3 meters. In this case, the ' n ' factor has a value of 1.5. The data file, DIPOLEN5.DAT, gives an example of a dipole-dipole data set with non-integer ' n ' values. For cases where the fractional part of the n factor has an infinite series in decimal notation, the ' n ' value should be given to at least four decimal places. For example, if the ' n ' value is one and one-third, it should be given as 1.3333.

If the location of the first electrode is used in the data format, it should be the leftmost electrode; such as the C2 electrode in Figure 5a and Figure 5b, C1 in Figure 5c and P2 in Figure 5d.

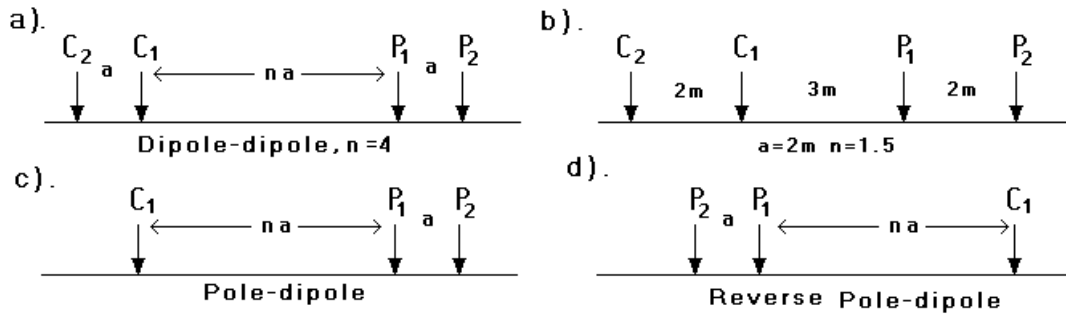

Figure 5. Arrangement of the electrodes for the dipole-dipole and pole-dipole arrays. (a) Dipole-dipole array with integer 'n' factor. (b) Example of dipole-dipole array with non-integer "n" value. Arrangement of the electrodes for (c) the "forward" and (d) "reverse" pole-dipole arrays.

There are two other issues involved with the pole-dipole array. The first is that the current electrode can be to the left (normal arrangement) or to the right (reverse arrangement) of the potential electrodes. To distinguish between the two arrangements, a positive value is used for the 'n' factor in the normal arrangement, and a negative value for the 'reverse' arrangement. The pole-dipole array is an asymmetrical array, and over symmetrical structures the apparent resistivity anomalies in the pseudosection are also asymmetrical. In some situations, the asymmetry in the measured apparent resistivity values could influence the model obtained after inversion. One method to eliminate the effect of this asymmetry is to repeat the measurements with the electrodes arranged in the reverse manner. By combining the measurements with the "forward" and "reverse" pole-dipole arrays, any bias in the model due to the asymmetrical nature of this array would be removed. The file PDIPREV.DAT is an example data set that combines measurements made with the "forward" and "reverse" pole-dipole arrays (Table 6). There is no common standard to define the position of the pseudosection x plotting position for the pole-dipole array as it is a non-symmetrical array. There are two possible conventions, to use the mid-point between the P1-P2 electrodes or the mid-point between the C1-P2 electrodes. This program uses the mid-point between the C1-P2 electrodes to define the x -location of the array.

Table 6. Example pole-dipole array data file.

<i>PDIPREV.DAT file</i>	<i>Comments</i>
Forward and reverse pole-dipole array	<i>Name of survey line</i>
7.0	<i>Unit electrode spacing</i>
6	<i>Array type, 6 for pole-dipole</i>
162	<i>Number of data points</i>
0	<i>Type of x-location for data points, 0 for first electrode</i>
0	<i>Flag for I.P. data, 0 for none (1 if present)</i>
0,63,1,0.8277	<i>x-location, 'a' spacing, 'n' factor, apparent resistivity,</i>
0,56,1,0.8236	<i>2nd data point</i>
0,49,1,0.8888	<i>3rd data point</i>
..	<i>Same format for other data points</i>
..	
0,63,-1,2.298	<i>82nd data point, 'n' value of -1 for reverse pole-dipole</i>
...	
0,7,-1,102.4	<i>Last data point, note a=7.0 and n=-1</i>
0,0,0,0	<i>Ends with a few zeros. Flags for other options.</i>

Another variation of the pole-dipole array is the offset pole-dipole array. This array was originally designed to carry out 3-D I.P. surveys rapidly (White *et al.*, 2003), thus data from such surveys are normally processed with the 3-D inversion program RES3DINVx64. Support is provided for the array in this program so that users have the option of inverting each line individually. The arrangement of the

electrodes is shown in the Figure 6. The arrangement is similar to that used by the normal pole-dipole array except that the current electrode is not on the same line as the potential electrodes but offset at a distance “ b ” from the survey line. This arrangement was used to reduce the EM coupling between the current electrode and the potential dipole. The RES2DINVx64 program does not support the case when the C1 electrode is immediately below the P1 electrode (i.e. $n=0$). For a data set with this arrangement, you will need to use the RES3DINVx64 program. Another restriction is that the ‘ b ’ offset distance is the same for all the data points. If different ‘ b ’ values are used in the survey, you will also need to use the RES3DINVx64 program. The file OFF_PDP.DAT gives an example of the data format for this array. Table 7 shows the initial part of this data file with comments about the format. The data format is essentially the same as the normal pole-dipole array, except the array number is 10 and the offset distance is given immediately after the array number.

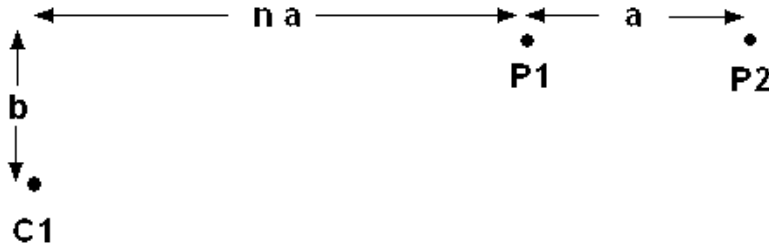

Figure 6. Arrangement of electrodes for the offset pole-dipole array.

Table 7. Example offset pole-dipole array data file.

<i>OFF_PDP.DAT file</i>	<i>Comments</i>
Blocks with IP	<i>Title</i>
2.00	<i>Unit electrode spacing</i>
10	<i>Array type (10 for offset pole-dipole)</i>
1.00	<i>Offset of current electrode from survey line</i>
530	<i>Number of data points</i>
1	<i>1 for mid-point of array given as x-location</i>
1	<i>1 to indicate IP present</i>
Chargeability	<i>Type of IP data</i>
Msec	<i>IP unit</i>
0.10,1.00	<i>Delay, integration time</i>
2.0 2.0 1.0 100.7976 -0.9118	<i>For each data point, we have</i>
4.0 2.0 1.0 102.0548 -1.8678	<i>x-location, “a” dipole spacing, “n” factor,</i>
6.0 2.0 1.0 104.9487 -4.3391	<i>apparent resistivity, apparent IP</i>
8.0 2.0 1.0 111.0159 -9.0335	
.....	<i>Other data points</i>
.....	
53.0 2.0 -10.0 109.3857 5.5469	<i>Last data point</i>
0,0,0,0,0	<i>A few zeros to end the file</i>

7.1.3 Topography data for index based format data files

The topography data is entered immediately after the main section with the apparent resistivity values. The file GLAD0E2.DAT is an example with topographical data. The bottom section of this file with a description of the format for topographical data is given in Table 8. Note that the topography data is placed immediately after the apparent resistivity data points. The first item is a flag to indicate whether the file contains topography data. If there is no topography data, its value is 0. Enter 1 or 2 if topographical data is present. In the case where the actual horizontal and vertical coordinates of topography data points along the survey line are given, enter 1. Even if the actual horizontal distances are given in the topography data section, you must still use the x -distance along the ground surface in the apparent resistivity data section. In most surveys the distances of the points along the ground surface, and not true horizontal distances, are actually measured with a tape or using a cable with takeouts at regular intervals. In this case, enter a value of 2 for the topography data flag. This is followed by the number of topographical data points.

It is not necessary to measure the elevation for each electrode. For example, the data in the GLADOE2.DAT file involves 161 electrodes but only the elevations at 26 points are given. The maximum number of topographical data points you can have is 4000. For each data point, the horizontal location and the elevation is entered into the data file. After the last topographical data point, the number of the topographical data point where the first electrode is located is given. In the above example, the first electrode was located at -40 meters, which corresponds to the 2nd topographical data point. Note that the elevation of the first electrode is required. If this was not measured in the field, you can estimate it from the elevations of the neighboring data points. In most cases, the first topographical data point corresponds to the first electrode and the last topographical data point corresponds to the last electrodes. An example data file with this arrangement is RATHCRO.DAT. By tying the first and last topographical data points to the first and last electrodes, this will help to avoid errors in the data format.

Table 8. Example of index based data file with topography.

<i>GLADOE2.DAT file</i>	<i>Comments</i>
237 2 39.207	<i>Last four data points</i>
203 2 14.546	<i>with x-location of the data point, electrode spacing</i>
227 2 31.793	<i>and measured apparent resistivity values</i>
233 2 30.285	
2	<i>Topography data flag. If no topography data, place 0 here.</i>
26	<i>Number of topography data points</i>
-100 33	<i>Horizontal and vertical coordinates of 1st,</i>
-40 34.5	<i>2nd topography data point</i>
-20 35.0	<i>This is followed by similar data for</i>
0 35.209	<i>the remaining topography data points</i>
..	
..	
..	
300 33	<i>Last topography data point</i>
2	<i>The topography data point number with the first electrode</i>
0,0,0,0,0	<i>A few zeros to end the file</i>

7.2 General array data format

This feature is to cater for electrode arrangements that do not fall under the usual array types or electrode arrangements, or unusual ways of carrying out the surveys. There are probably an infinite number of possible electrode configurations that are limited only by the imagination of the user but in most cases they are likely to be slight variations of the standard arrays. Figure 7 shows four possible non-standard configurations. One possibility is a non-symmetrical variation of a symmetrical array, such as the Wenner-Schlumberger or the dipole-dipole array (Figure 7a,b,d). Such a configuration could arise from surveys with multi-channel resistivity meters where measurements are made with several pairs of potential electrodes for a common pair of current electrodes. While the program gives the user greater latitude in the electrode arrangement, some arrays that are technically possible but would have very low potential signals should be avoided.

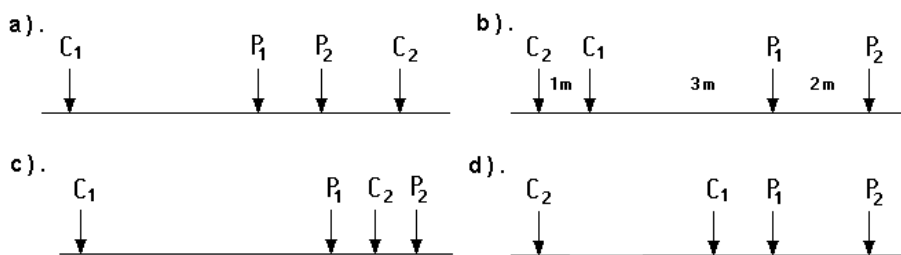

Figure 7. Some possible non-conventional arrays. (a) Non-symmetrical four-electrode Wenner-Schlumberger or gradient type of array. (b) Dipole-dipole array with dipoles of unequal size. (c) A possible but probably non-viable electrode configuration. (d) Highly non-symmetrical dipole-dipole array.

To accommodate the various possibilities, a general array data format where the positions of all the four electrodes are listed is used. The x -location as well as the elevation of all the electrodes used in a measurement must be given. The file MIXED.DAT is an example data file with such a format. This is actually a synthetic data set with a mixture of measurements using the Wenner-Schlumberger and dipole-dipole arrays. The initial part of this data file with comments about the format is given in Table 9.

The sub-array type indicator is used when the electrode configuration follows one of the conventional arrays, for example the Wenner-Schlumberger array. As an example, the file MIXEDWS.DAT has the data for a Wenner-Schlumberger array only but the information is arranged in a general array format. In this case the sub-array number is 7. The file RATHCMIX.DAT (Table 10) has the data for the Rathcroghan mound (Waddell and Barton, 1995) for the Wenner array but in a general array format (thus it has sub-array number of 1). For these data sets, the apparent resistivity values can be displayed in the form of a pseudosection. Table 10 lists the data format used for this data set. The file MIXED.DAT is a combined data set with measurements using the Wenner-Schlumberger and dipole-dipole array. In this case, there is no consistent array type, so the sub-array number is given as 0.

Table 9. Example data file with general array format.

<i>MIXED.DAT file</i>	<i>Comments</i>
Mixed array	<i>Name of survey line</i>
1.0	<i>Unit electrode spacing</i>
11	<i>Array type (11 for general array)</i>
0	<i>Array type, 0 non-specific</i>
Type of measurement (0=app. resistivity, 1=resistance)	<i>Header</i>
0	<i>0 to indicate apparent resistivity</i>
407	<i>Number of data points</i>
1	<i>Type of x-location, 0 for true horizontal distance</i>
0	<i>Flag for I.P. data, 0 for none (1 if present)</i>
4 0.0 0.0 3.0 0.0 1.0 0.0 2.0 0.0 10.158	<i>The format for each data point is :-</i>
4 1.0 0.0 4.0 0.0 2.0 0.0 3.0 0.0 10.168	<i>Number of electrodes used,</i>
4 2.0 0.0 5.0 0.0 3.0 0.0 4.0 0.0 10.184	<i>x- and z-location of C1, C2, P1, P2,</i>
4 3.0 0.0 6.0 0.0 4.0 0.0 5.0 0.0 10.225	<i>Apparent resistivity or resistance value</i>
4 4.0 0.0 7.0 0.0 5.0 0.0 6.0 0.0 10.337	
..	
..	<i>Same format for other data points</i>
..	
4 27.0 0.0 26.0 0.00 33.0 0.0 34.0 0.0 6.765	<i>Last data point</i>
0,0,0,0	<i>Ends with a few zeros.</i>

Concerning the indicator for the type of x -location, there are two possible values. A value of 1 is used if the x -location values are the true horizontal distances, while a value of 2 is used if it is the distance along the ground surface. This is similar to the convention used for topography data for the index based format (Section 7.1.3).

In the RATHCMIX.DAT file, the topography information is included as the elevation for each electrode in every data line. In some cases, it might be more convenient to enter the topography information in a separate list, much like for data in the index based format. One example with data in the general array format but with the topography in a separate list after the apparent resistivity data lines is given in the file RATHCMIX_Sep_Topo.DAT. Part of the file is shown in Table 11. Note the addition of an extra header line “*Topography in separate list*” that indicates the topography information is in a separate list after the apparent resistivity data lines. Note also in the data lines, the elevation for each electrode is given as 0.00. The program will calculate the elevation for the electrodes from the topography information.

Table 10. Example general array format file with topography.

<i>RATHCMIX.DAT file</i>	<i>Comments</i>
Rathcrogan	<i>Name of survey line</i>
2.0	<i>Unit electrode spacing</i>
11	<i>Array type (11 for general array)</i>
1	<i>Sib-array type, 1 for Wenner</i>
Type of measurement (0=app. resistivity,1=resistance)	<i>Header</i>
0	<i>0 to indicate apparent resistivity</i>
399	<i>Number of data points</i>
2	<i>Type of x-location, 2 for surface distance</i>
0	<i>Flag for I.P. data, 0 for none (1 if present)</i>
4 -36.0 0.044 -30.0 0.503 -34.0 0.134 -32.0 0.311 116.0	<i>First data point, note non-zero elevation after x-location of each electrode.</i>
4 -34.0 0.134 -28.0 0.712 -32.0 0.311 -30.0 0.503 118.0	<i>Second data point</i>
..	<i>Same format for other data points</i>
..	
..	
4 58.0 0.385 94.0 -3.270 70.0 -2.095 82.0 -2.853 1160.0	<i>Second last data point</i>
4 60.0 -0.093 96.0 -3.340 72.0 -2.274 84.0 -2.914 1680.0	<i>Last data point</i>
0,0,0,0	<i>Ends with a few zeros.</i>

Table 11. Example general array data format file with topography in a separate section.

<i>RATCMIX_Sep_Topo.DAT file</i>	<i>Comments</i>
Rathcrogan	<i>Name of survey line</i>
2.0	<i>Unit electrode spacing</i>
11	<i>Array type (11 for general array)</i>
1	<i>Sib-array type, 1 for Wenner</i>
Type of measurement (0=app. resistivity,1=resistance)	<i>Header</i>
0	<i>0 to indicate apparent resistivity</i>
399	<i>Number of data points</i>
2	<i>Type of x-location, 2 for surface distance</i>
0	<i>Flag for I.P. data, 0 for none (1 if present)</i>
4 -36.0 0.0 -30.0 0.0 -34.0 0.0 -32.0 0.0 116.0	<i>First data point, note non-zero elevation after x-location of each electrode.</i>
4 -34.0 0.0 -28.0 0.0 -32.0 0.0 -30.0 0.0 118.0	<i>Second data point</i>
..	<i>Same format for other data points</i>
..	
..	
4 58.0 0.0 94.0 0.0 70.0 0.0 82.0 0.0 1160.0	<i>Second last data point</i>
4 60.0 0.093 96.0 0.0 72.0 0.0 84.0 0.0 1680.0	<i>Last data point</i>
Topography in separate list	<i>Extra header required for general array</i>
2	<i>2 to indicate surface distance</i>
67	<i>Number of topography data points</i>
-36,0.044	<i>Horizontal and vertical coordinates of 1st,</i>
-34,0.134	<i>2nd topography data point</i>
..	<i>This is followed by similar data for</i>
..	<i>the remaining topography data points</i>
96,-3.34	<i>Last topography data point</i>
1	<i>The topography data point number with the first electrode</i>
0,0,0,0	<i>Ends with a few zeros.</i>

The measurement can be given in terms of resistance or apparent resistivity. If there is no topography, i.e. the z -locations are all equal to zero or the same, the conventional formula can be used to calculate the apparent resistivity. The geometric factor k is given by the following equation

$$k = \frac{2\pi}{\left(\frac{1}{r_1} - \frac{1}{r_2} - \frac{1}{r_3} + \frac{1}{r_4}\right)} \quad (7.2)$$

where r_1 is the distance between the C1 and P1 electrodes, r_2 is the distance between the C1 and P2 electrodes, r_3 is the distance between the C2 and P1 electrodes and r_4 is the distance between the C2 and P2 electrodes. In the case when there is no topography, the distance between two electrodes is simply the difference in the x -locations of the two electrodes.

In the case where topography is present, there is no widely accepted convention. To be consistent with the format used earlier, two different conventions are used depending on the type of x -location given in the data file. If the x -locations are given as distances along the surface (i.e. not true horizontal distances), the distance between two electrodes is calculated by using the difference in the values of the x -locations only.

If the x -locations are true horizontal distances, the default option is that the true distance between two electrodes is used in the calculation of the geometric factor. For example, if the C1 and P1 electrodes are located at (x_1, z_1) and (x_2, z_2) respectively, then

$$r_1 = \sqrt{r_x^2 + r_z^2} \quad (7.3)$$

where

$$r_x = x_1 - x_2$$

$$r_z = z_1 - z_2$$

In the case where the ground surface has a constant slope, both conventions will give the same geometric factor.

To accommodate a situation where the x -locations are true horizontal distances, but the geometric factor was calculated using only the x -positions, a couple of extra lines must be inserted in the data file just after the flag to indicate the type of measurement, as shown in the table below. A flag value of '0' is used to indicate only the horizontal distances between the electrodes are used to calculate the geometric factor.

<i>Example file</i>	<i>Comments</i>
....	<i>Initial part of file is same</i>
....	<i>as in previous examples</i>
11	<i>Array type (11 for general array)</i>
0	<i>Sib-array type, 1 for Wenner</i>
Type of measurement (0=app. resistivity, 1=resistance)	<i>Header</i>
0	<i>0 to indicate apparent resistivity</i>
Type of geometric factor (0=Horizontal distance, 1=Linear distance)	<i>Extra header for situation where horizontal distances are used for the geometric factor</i>
0	<i>0 for horizontal distance, 1 for linear distance</i>
300	<i>Number of data points</i>
1	<i>Type of x-location, 1 for true horizontal distances</i>
0	<i>Flag for I.P. data, 0 for none</i>
....	<i>Rest of file follows normal format</i>
....	

Note that in the general array data format, the z -location is the elevation of the electrode which is positive in the upwards direction. This unfortunately is different from the format for the borehole data set where the z -values are positive in the downwards direction.

Figure 8 shows an interesting arrangement where the electrodes are arranged such that the *true horizontal* distances between adjacent electrodes are constant. When the slope of the ground surface is not constant, this results in an arrangement where the distance between adjacent electrodes as measured along the ground surface is not constant but depends on the slope. In areas where the slope is steeper, the distance between adjacent electrodes along the ground surface is greater. To accommodate such an arrangement, the general array format can be used. In this case, the indicator for the type of x -location must be 1 since the true horizontal distances are given in the data. Very often, the survey is carried out with one of the conventional arrays, such as the Wenner-Schlumberger, so the appropriate sub-array number should also be given.

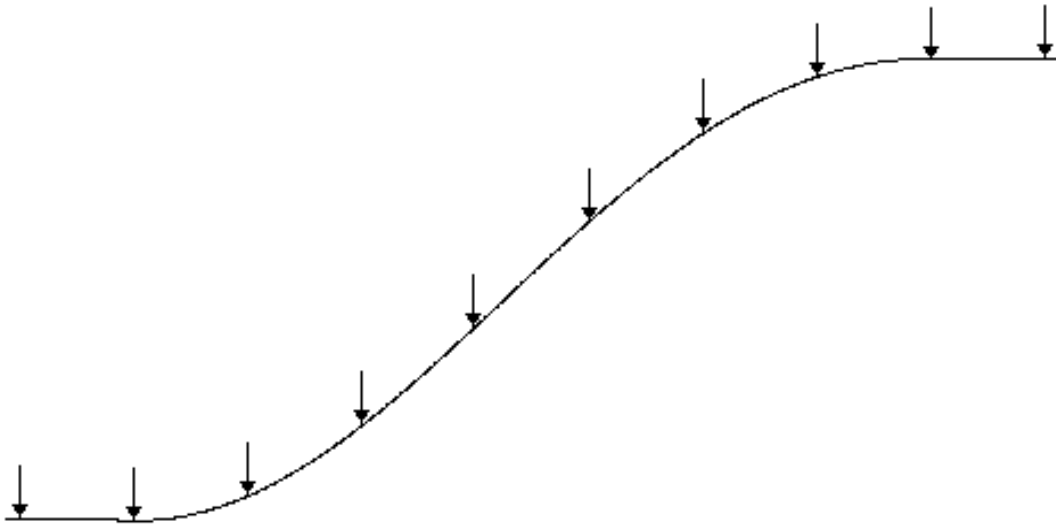

Figure 8. Arrangement of the electrodes along a survey line such that the true horizontal distance between adjacent electrodes is constant regardless of the slope of the ground surface. Note that the distance between adjacent electrodes along the ground surface is greater at the steeper part of the slope.

In some cases, the 2-D data set is generated from a series of collinear 1-D sounding lines. In such a situation, the distance between adjacent electrodes is not constant, whether as measured along the surface or in the true horizontal direction. For such a case, the general array format (with a sub-array type of 0) can be used.

For data sets with a sub-array type of 0, the data cannot be displayed in the form of a pseudosection, nor can it be edited with the "Exterminate bad data points" option. To remove bad data points from the data set, you need to first carry out an inversion of the entire data set. However, you should use the "Robust data constrain" (see section 11.2.1) to ensure that bad data points do not have a large effect on the inversion results. Next, go to the "Display" window and read in the file with the inversion results. Select the "RMS error statistics" sub-option under the "Edit data" menu (section 14.4.1). This will display a histogram where the data points are grouped according to the difference between the measured and calculated apparent resistivity values. This allows you to remove the data points where a large difference occurs, for example more than 100 percent. After removing the noisier data points, save the trimmed data set in a file and carry out the inversion again with the trimmed data set.

The multiple gradient array (**Error! Reference source not found.**) is becoming popular with multi-channel systems (Dahlin and Zhou 2006). The data for the gradient array must be given in the general array format with a sub-array number of 15. A listing of the example GRADIENT.DAT file with comments about the format is given in Table 12.

Table 12. Example gradient array data file.

<i>GRADIENT.DAT file</i>	<i>Comments</i>
Gradient array	<i>Name of survey line</i>
1.0	<i>Unit electrode spacing</i>
11	<i>Array type (11 for general array)</i>
15	<i>Sib-array type, 1 for Wenner</i>
Type of measurement (0=app. resistivity, 1=resistance)	<i>Header</i>
0	<i>0 to indicate apparent resistivity</i>
1792	<i>Number of data points</i>
1	<i>Type of x-location, 2 for surface distance</i>
0	<i>Flag for I.P. data, 0 for none</i>
4 0.0,0.0 9.0,0.0 1.0,0.0 2.0,0.0 5.0588	<i>First data point</i>
4 1.0,0.0 10.0,0.0 2.0,0.0 3.0,0.0 5.0724	<i>Second data point</i>
..	
..	<i>Same format for other data points</i>
..	
4 46.0,0.0 118.0,0.0 78.0,0.0 86.0,0.0 4.2571	<i>Second last data point</i>
4 48.0,0.0 120.0,0.0 80.0,0.0 88.0,0.0 4.2258	<i>Last data point</i>
0,0,0,0	<i>Ends with a few zeros.</i>

7.3 Remote electrodes of the pole-pole and pole-dipole arrays

In theory, the pole-pole array has only 2 electrodes, the positive current electrode C1 and the positive potential electrode P1. In practice, such an array does not exist since all field measurements are made using an array with 4 electrodes (Figure 9).

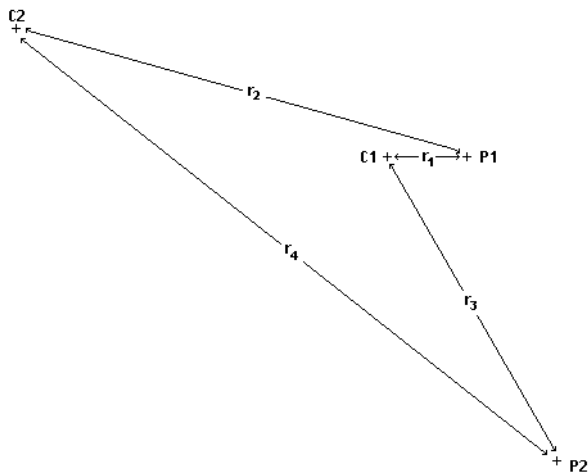

Figure 9. A schematic diagram of the arrangement of the electrodes in an actual field pole-pole measurement.

To minimize the effects of the C2 and P2 electrodes, it is generally recommended that the distance of these two electrodes from the C1 and P1 electrodes should be at least 10 times (and preferably 20 times) the maximum C1-P1 spacing r_1 . In some cases, when large spacings between the C1 and P1 electrodes are used, this requirement is not met for all measurements. This could lead to distortions in the inversion model (Robian et al. 1997). To overcome this problem, the RES2DINV program allows the user to incorporate the effects of the C2 and P2 electrodes in the inversion.

To calculate the apparent resistivity value measured with the non-ideal pole-pole array, two possible geometric factors can be used. One method is to use the same equation as the ideal pole-pole array. This gives an approximate geometric factor since the resulting apparent resistivity value is not the same as the true resistivity for a homogeneous half-space. Alternatively, the exact geometric factor that takes into account the positions of the C2 and P2 electrodes can be used.

$$\begin{aligned} \text{Approximate Geometric factor (ideal pole-pole array)} &= 2 \cdot \pi \cdot r_1 \\ \text{Exact Geometric factor} &= 2 \pi / [(1/r_1) - (1/r_2) - (1/r_3) + (1/r_4)] \end{aligned} \quad (7.4)$$

The program supports both conventions. A possible arrangement of the electrodes in a pole-pole survey is shown in Figure 10. In this case, the C2 and P2 electrodes are fixed throughout the survey. The measurements are made by using different pairs of electrodes along the survey line as the C1 and P1 electrodes. For a survey line with n electrodes, there are $n(n+1)/2$ possible combinations. For example, if there are 25 electrodes in the survey line, there are 300 possible combinations. In practice, not all the possible measurements are made. Instead a maximum distance between the C1 and P1 electrodes is set depending on the maximum depth of investigation needed (Edwards 1977). In many cases, this maximum distance is 6 to 10 times the unit electrode spacing along the survey line. To avoid the possibility of negative or zero apparent resistivity values, the distance of the C2 and P2 electrodes must be at least 3 times the maximum C1 to P1 spacing used. For example, if the unit electrode spacing is 1 meter, and the maximum C1-P1 spacing is 10 meters, then the C2 and P2 electrodes must be at least 30 meters from the survey line. Note that as the distance of the C2 and P2 electrodes from the survey line decreases, the effective maximum depth of investigation of the survey also decreases. It might be significantly less than the depth of investigation for the ideal pole-pole array (Edwards 1977).

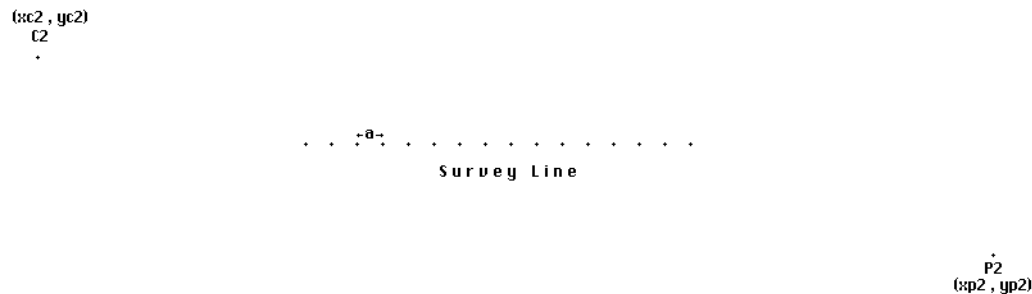

Figure 10. A schematic diagram of the arrangement of the electrodes along the survey line in a pole-pole survey with positions of the C2 and P2 electrodes specified.

The file POLPOLFX.DAT is an example data file with pole-pole measurements where the locations of the C2 and P2 remote electrodes are specified. A description of the format used is given in Table 13. Although the z -locations of the electrodes are also included in the file data format for completeness, the values are presently not used by the program. The program at present estimates the heights at the remote electrodes from the heights of the electrodes along the survey line. However, in future, they might be used to accommodate extreme cases where slope of the ground at the remote electrodes is very different from that along the survey line.

The data format is the same as that for normal pole-pole surveys except for the section (after the array number) which contains information about the location of the second current and potential electrodes. The data line “Exact Geometric factor used” is used to indicate that the apparent resistivity values in the data file were calculated using the exact geometric factor. If the approximate geometric factor was used, this data line should be given as “Approximate Geometric factor used”. The file POLDPLFA.DAT is an example data file for a pole-dipole survey where the approximate geometric factor was used in calculating the apparent resistivity values. Note that in this file, only the location of the second current electrode C2 is given.

For the pole-pole array, the effect of the C2 electrode is approximately proportional to the ratio of the C1-P1 distance to the C2-P1 distance. If the effects of the C2 and P2 electrodes are not taken into account, the distance of these electrodes from the survey line must be at least 20 times the largest C1-P1 spacing used to ensure that the error is less than 5%. In surveys where the inter-electrode spacing along the survey line is more than a few meters, there might be practical problems in finding suitable locations for the C2 and P2 electrodes to satisfy this requirement. Thus, the error in neglecting the effects of the remote electrodes is greatest for the pole-pole array. As a general guide, if the distances of the C2 and P2 electrodes from the survey line are more than 20 times the largest C1-P1 spacing used, the array can be treated as an ideal pole-pole array for interpretation purposes. Otherwise, the coordinates of the C2 and P2 electrodes should be recorded so that their effects can be determined by this program. However, it should be noted that as the distance of the P2 electrode from the survey line increases, the telluric noise

picked up by the P1-P2 pair also increases. This factor should also be taken into account when positioning the P2 electrode.

For the pole-dipole array, the effect of the C2 electrode is approximately proportional to the *square* of ratio of the C1-P1 distance to the C2-P1 distance (Loke 2018). Thus, the pole-dipole array is less affected by the C2 remote electrode. If the distance of the C2 electrode is more than 5 times the largest C1-P1 distance used, the error caused by neglecting the effect of the C2 electrode is less than 5% (the exact error also depends on the location of the P2 electrode for the particular measurement). So, as a general guide, if the distance of C2 electrode from the survey line is more than 5 times the largest C1-P1 spacing, it can be treated as an ideal pole-dipole array. Otherwise, enter the coordinates of the C2 electrode into the data file. For the pole-dipole array, only the header and coordinates of the C2 electrode is required in the data file.

Table 13. Pole-pole data file with remote electrodes specified.

<i>POLPOLFX.DAT file</i>	<i>Comments</i>
Blocks Model	<i>Name of survey line</i>
2.0	<i>Unit electrode spacing</i>
2	<i>Array type (2 for pole-pole)</i>
Remote electrodes included	<i>Header to indicate position of remote electrodes included in data file</i>
C2 remote electrode X, Y and Z location	<i>Header for C2 electrode location</i>
-50.000,20.000,0.0	<i>x-, y- and z-location of C2 electrode</i>
P2 remote electrode X, Y and Z location	<i>Header for P2 electrode location.</i>
120.000,0.000,0.0	<i>x-, y- and z-location of P2 electrode</i>
Exact Geometric factor used	<i>Type of geometric factor used</i>
295	<i>Number of data points</i>
1	<i>1 indicates center of array is given</i>
0	<i>0 for no IP</i>
1.00 2.00 10.13	<i>x-location, electrode spacing apparent resistivity for 1st data point</i>
3.00 2.00 10.18	<i>Second data point</i>
..	<i>The rest follows standard index based</i>
..	<i>format.</i>
..	

7.4 Cross-borehole data format

The resolution of electrical surveys carried out with electrodes on the ground surface decreases exponentially with depth. One method to obtain reasonably good resolution at depth is by making measurements with the electrodes in boreholes. Cross-borehole surveys are much less frequently carried out compared to surface based surveys, so unlike surface surveys, there are at present no common standards with regards to the arrangement of the electrodes. The cross-borehole option in this program is intended for shallow surveys with the arrangement of the electrodes placed in a certain general pattern (Sasaki 1992). The basic arrangement of the electrodes is shown in the Figure 11. The RES2DINVx64 programs support up to 100 boreholes.

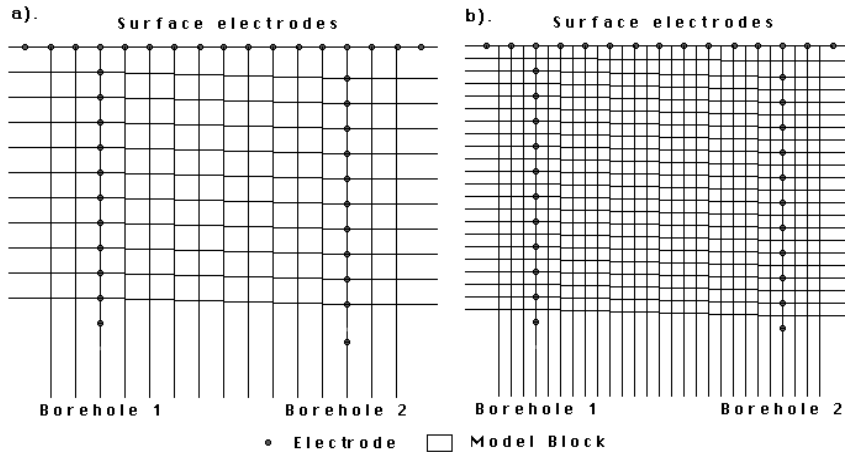

Figure 11. Arrangement of the electrodes in a cross-borehole survey. (a) The default standard model where the dimensions of the model blocks are equal to the spacing between the electrodes. (b) An alternative model with finer blocks with dimensions about half the spacing between the electrodes.

The electrodes are divided into 2 sets with (i) the surface electrodes, (ii) electrodes in the boreholes. It is assumed that the boreholes do not have a metal casing which would severely alter the pattern of the current flow. The program divides the subsurface into a number of quadrilateral blocks (Figure 11). Note that the positions of the surface and borehole electrodes control the manner in which the subsurface is divided into the model blocks. The file BOREDIF.F.DAT is an example data file with cross-borehole measurements. A description of the format used is given in Table 14. Note that in this example, the measurements are made with the pole-dipole array where only the C1, P1 and P2 electrodes are used. It is assumed the boreholes are vertical. Thus, the x -locations of all the electrodes in the same borehole are the same in Table 14. The array number is 12 for cross-borehole survey data with the measurements given as apparent resistivity values. You can also enter the data as resistance measurements, in which case the array number is 13. This might be more convenient as most resistivity meters give the readings as a resistance value in ohm, and furthermore the geometric factor for arrays with subsurface electrodes is different from the geometric factor for conventional surface arrays. The file BORERES.DAT gives an example where the measurements are given as resistance values. An interesting field data set where the pole-pole array was used, and the measurements are also given as resistance values, is BORELUND.DAT from Lund University, Sweden.

If only two electrodes are used in a measurement, only the x - and z -locations of the C1 and P1 electrodes are given in the data file (see the file BOREHIP.DAT which also contains IP measurements). However, if all four electrodes are used, the x - and z -locations of the C1, C2, P1 and P2 electrodes must be given in this order. You can combine measurements made with different numbers of electrodes in the same data file.

When the program reads in a file with resistance values, you have a choice of inverting the data set using apparent resistivity values, or directly use the resistance values. Using resistance values directly in the inversion has the advantage of allowing you to use readings where the apparent resistivity value does not exist (due to an infinite geometric factor). After reading in a data file, the program will attempt to filter out suspicious readings with potentially high noise levels if the measurements are given as apparent resistivity values, or if you had chosen the option to use apparent resistivity values in the inversion. If you choose to carry out the inversion using resistance values, the readings are not filtered.

The geometric factor for subsurface electrodes is different from that used for surface electrodes. As an example, the geometric factor for a measurement where only two electrodes are used is as follows.

If the C1 and P1 electrodes are located at (x_1, z_1) and (x_2, z_2) respectively, the geometric factor k is then given by

$$k = 4\pi / \left(\frac{1}{r_1} + \frac{1}{r_1'} \right) \quad (7.5)$$

where $r_1 = \sqrt{dx^2 + dz^2}$, $dx = x_1 - x_2$, $dz = z_1 - z_2$
 $r_1' = \sqrt{Dx^2 + dz^2}$, $Dz = z_1 + z_2$

Similar equations for measurements with 3 or 4 electrodes can be easily obtained by adding the appropriate terms.

The depth of the electrodes in Borehole 1 can be different from the corresponding electrodes in Borehole 2. In practice, to get the best results the depths should not differ too much. This program requires that the number of electrodes in both boreholes must be the same. In practice, this restriction is not a significant problem. You can be easily overcome this restriction by inserting dummy electrodes into the data set if the number of electrodes in one borehole is less (in the section where the x - and z -location of the electrodes in the borehole are given).

The program also requires that a surface electrode is located at the top of both boreholes. If they do not physically exist, just insert dummy electrodes at the appropriate locations in the data file. Also, there should be at least a few surface electrodes between the two boreholes, as well as at least two surface electrodes to the left of borehole 1, and another two to the right of borehole 2. If such electrodes were not used in the field survey, just insert dummy electrodes into the data file to satisfy the requirements of this program.

By default, the program will subdivide the subsurface into quadrilateral blocks such that the dimensions of the blocks are equal to the spacing between the electrodes (Figure 11a). However, you can also choose to use a model where the dimensions of the blocks are about half the spacing between the electrodes (Figure 11b). Using the model with a finer discretization could significantly improve the inversion results in some cases (Sasaki 1992). Please refer to section 11.3.10 to set the type of borehole model to use. In theory, it is possible to further subdivide the subsurface into even smaller blocks. However, since the resolution of electrical measurements decreases rapidly with distance from the measuring electrodes, this is unlikely to significantly improve the results. In fact, it could result in unnatural oscillations in the model resistivity values, particularly near the electrodes. This is as a result of the well-known trade-off between model resolution and model variance in geophysical inversion.

Figure 12 shows the model obtained after the inversion of the BOREHOLE.DAT data set. This is a synthetic data set produced by a forward modeling program with a high resistivity block in between the two boreholes. The option to use finer blocks with half the size of the spacing between the electrodes was used in the inversion of this data set. Figure 13 shows the inversion results from an interesting field data set. This data set is one from a number that were collected by a survey to study the flow of fluids through the UK Chalk aquifer in east Yorkshire by using a saline tracer (Slater et al. 1997). There is a low resistivity zone near the surface where the saline solution was irrigated onto the ground, and also prominent low resistivity zones below a depth of 7 meters due to the saline tracer that had flowed downwards. Another interesting feature of this data set is that no surface electrodes were used. All the surface electrodes given in the BORELANC.DAT data file are dummy electrodes; two to the left of borehole 1 and another two to the right of borehole 2.

If I.P. measurements were also made, you need to enter a value of 1 at the 6th line in the data file, and two more data lines after that which gives the type of IP measurement used and the two parameters associated with it (see section 7.5). Next, enter the I.P. value after the apparent resistivity value for each data point. The file BOREHIP.DAT is an example cross-borehole data file with IP measurements.

The file boreholes_inclined.dat gives an example of the data format with non-vertical boreholes (Table 15). Note the addition of an additional header line 'Inclined boreholes present' just before the section with the positions of the boreholes to indicate that non-vertical boreholes are present. For inclined boreholes, the subdivision of the subsurface into model blocks is no longer tied directly to the positions of the electrodes. You can also use this format for vertical boreholes are where the corresponding electrodes at different boreholes are at different depths. This avoids inclined or skewed model blocks when there are significant differences in the borehole electrodes depths.

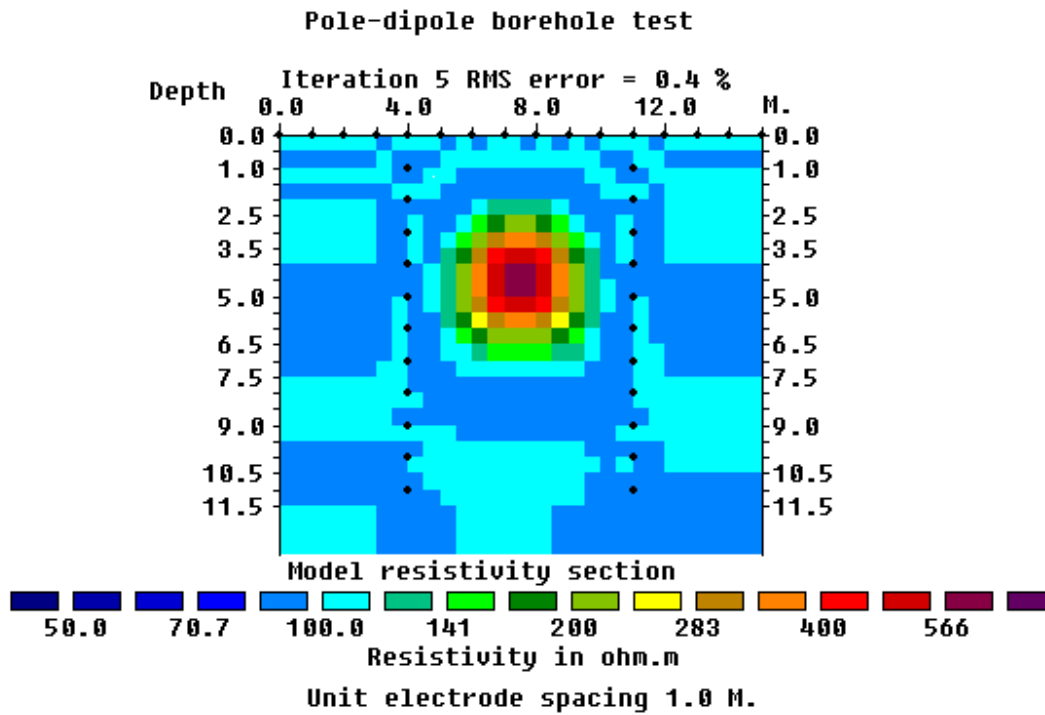

Figure 12. The model obtained after the inversion of the BOREHOLE.DAT data set. The option to use finer blocks with half the size of the spacing between the electrodes was used.

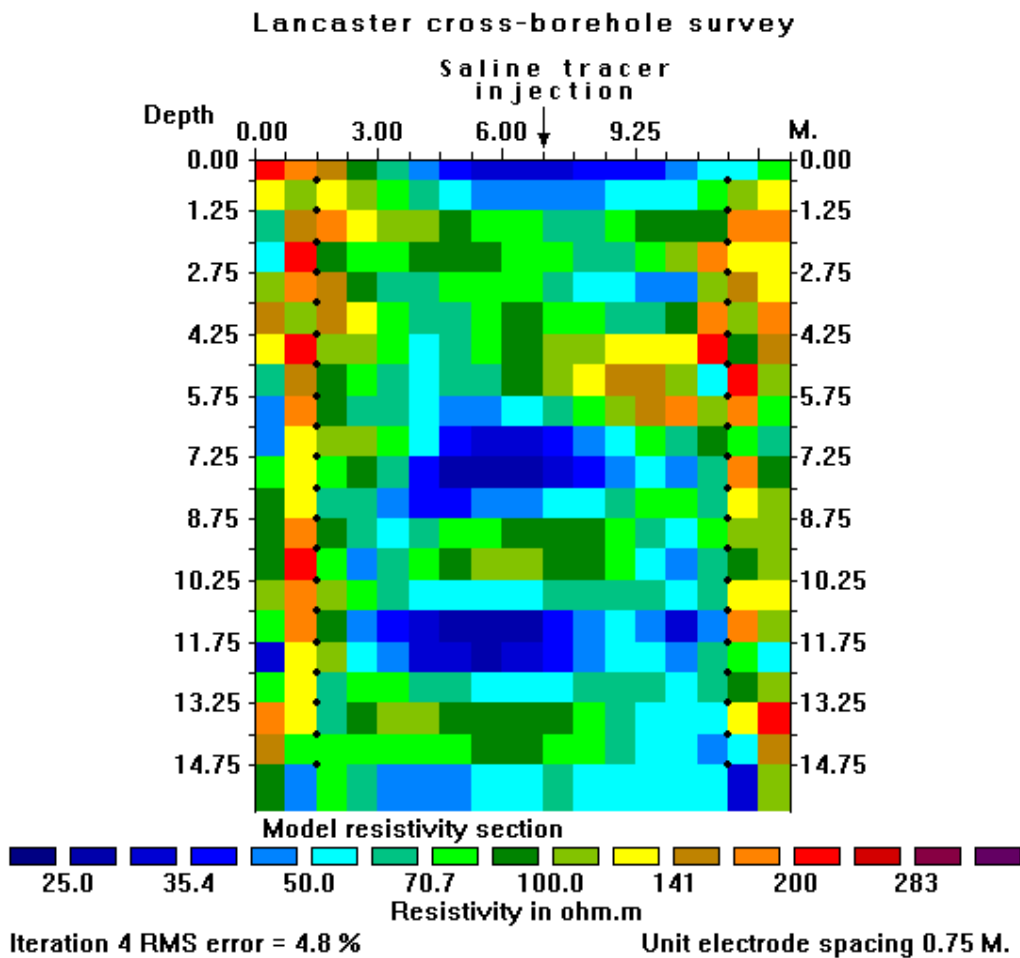

Figure 13. Model obtained from the inversion of data from a cross-borehole survey to map the flow of a saline tracer. Note the low resistivity zones near the surface (where the tracer was injected) and below a depth of 7 meters. The locations of the borehole electrodes are shown by small black dots.

Table 14. Example borehole data set.

<i>BOREDIFF.DAT file</i>	<i>Comments</i>
Borehole electrodes at different depths	<i>Name of survey line</i>
1.0	<i>Unit electrode spacing</i>
12	<i>Array number 12 for cross-borehole survey</i>
840	<i>Number of data points</i>
2	<i>2 to indicate XZ location format is used</i>
0	<i>0 for no I.P.</i>
Surface Electrodes	<i>Header for surface electrodes</i>
16	<i>Number of surface electrodes</i>
0.0, 0.0	<i>x- and z-location of first surface electrode</i>
1.0, 0.0	<i>Location of second surface electrode</i>
..	<i>Note 0.0 z value for surface electrode</i>
..	<i>Similar format for other surface electrodes</i>
..	
15.0, 0.0	<i>Last surface electrode</i>
Number of boreholes	<i>Header</i>
2	<i>Two boreholes in this data set</i>
Borehole 1 Electrodes	<i>Header for first borehole</i>
10	<i>Number of electrodes in first borehole</i>
4.0, 1.0	<i>x- and z-location of first electrode</i>
4.0, 2.0	<i>x- and z-location of second electrode</i>
4.0, 3.0	<i>Note electrodes are listed from the topmost</i>
..	<i>below the surface downwards</i>
..	<i>Similar format for other borehole electrodes</i>
..	
4.0, 10.0	<i>Last electrode in first borehole</i>
Borehole 2 Electrodes	<i>Header for second borehole</i>
10	<i>Number of electrodes in second borehole</i>
11.0, 1.5	<i>x- and z-location of first electrode</i>
11.0 2.5	<i>x- and z-location of second electrode</i>
..	
..	<i>Similar format for other borehole electrodes</i>
11.0, 10.5	<i>Last electrode in second borehole</i>
Measured data	<i>Header for section with the measurements</i>
3 0.0 0.0 1.0 0.0 2.0 0.0 101.5718	<i>The format for each data point is :-</i>
3 0.0 0.0 2.0 0.0 3.0 0.0 99.5150	<i>Number of electrodes used in measurement,</i>
3 0.0 0.0 3.0 0.0 4.0 0.0 99.2303	<i>x- and z-location of C1, C2, P1, P2</i>
3 0.0 0.0 4.0 0.0 5.0 0.0 99.1325	<i>electrodes, apparent resistivity value.</i>
..	
..	<i>Same format for other data points</i>
...	
3 11.0 11.0 11.0 3.5 11.0 2.50 120.8297	<i>Last data point</i>
0,0,0,0	<i>End with a few zeros.</i>

Table 15. Example data set with inclined boreholes.

<i>boreholes_inclined.dat file</i>	<i>Comment</i>
Example bipole-bipole configurations	<i>Title</i>
4.0	<i>Unit electrode spacing</i>
12	<i>Array number for borehole survey</i>
2555	<i>Number of data points</i>
2	<i>2 to indicate XZ location format used</i>
0	<i>0 for o I.P.</i>
Surface Electrodes	<i>Header</i>
26	<i>Number of surface electrodes</i>
0.0, 0.0	<i>x, z location of 1st surface electrode</i>
4.0, 0.0	<i>x, z location of 2nd surface electrode</i>
..	
..	
100.0, 0.0	<i>Last surface electrode</i>
Inclined boreholes present	<i>Extra header to indicate inclined boreholes</i>
Number of boreholes	<i>Header</i>
2	<i>Two boreholes present</i>
Borehole 1 Electrodes	<i>Header for first borehole</i>
20	<i>Number of electrodes in first borehole</i>
20.0, 4.0	<i>x, z location of 1st electrode in borehole 1</i>
20.0, 8.0	<i>x, z location of 2nd electrode in borehole 1</i>
..	
..	<i>Same format for other borehole electrodes</i>
..	
20.0, 80.0	<i>Last electrode in first borehole</i>
Borehole 1 Electrodes	<i>Header for second borehole</i>
20	<i>Number of electrodes in borehole</i>
80.0, 4.0	<i>First electrode in second borehole</i>
80.0, 8.0	<i>Second electrode in second borehole</i>
80.0, 12.0	
80.0, 16.0	
80.0, 20.0	
80.0, 24.0	
80.5, 28.4	<i>Note x-location is different, non-vertical</i>
80.0, 32.0	
..	
..	<i>Other borehole electrodes</i>
..	
80.0, 80.0	<i>Last electrode in second borehole</i>
Measured Data	<i>Header for start of apparent resistivity data</i>
4 4.0, 0.0 0.0,0.0 8.0,0.0 12.0, 0.0 101.6895	<i>First data value</i>
...	<i>Format is the same as before</i>

The file BOREHOLE_TOPO.DAT is a field example of a cross-borehole data set with topography. The initial part of this data file with a description of the format is given in Table 16.

Table 16. Example borehole data set with topography.

<i>BOREHOLE_TOPO.DAT file</i>	<i>Comment</i>
BOREHOLE WITH TOPOGRAPHY	<i>Name of survey line</i>
1.0	<i>Unit electrode spacing</i>
12	<i>Array number 12 for cross-borehole survey</i>
570	<i>Number of data points</i>
2	<i>2 to indicate XZ location format used</i>
0	<i>0 for o I.P.</i>
Topography Present	<i>Header to indicate topography is present</i>
Topography information mode (0=wrt to surface electrodes)	<i>Header</i>
0	<i>Indicates depths of borehole electrodes are given with respect to the surface electrode at the top of the borehole</i>
Type of x-distances	<i>Header</i>
2	<i>2 to indicate x-distances are along the surface</i>
Surface Electrodes	<i>Header</i>
31	<i>Number of surface electrodes</i>
-14.0000 0.00	<i>x, z location of 1st surface electrode</i>
-13.0000 0.03	<i>x, z location of 2nd surface electrode</i>
-12.0000 0.05	<i>Note non-zero z value</i>
..	
..	<i>Same format for other electrodes</i>
..	
16.0000 0.95	<i>Last surface electrode</i>
Borehole 1 electrodes	<i>Header for first borehole</i>
17	<i>Number of electrodes in borehole</i>
-14.0000 1.0000	<i>x, z location of 1st electrode in borehole 1</i>
-14.0000 2.0000	<i>x, z location of 2nd electrode in borehole 1</i>
..	<i>Rest of the file follows the usual format</i>
..	<i>for a cross-borehole data file</i>

Note that the topography information is given in the z-coordinates of the surface electrodes. The file BOREHOLE_Global.dat is an example where the true or GPS coordinates (section 7.11) of the electrodes on the surface are also available.

7.5 I.P. data format

The data collected from I.P. (Induced Polarization) surveys consists of two sets, the normal apparent resistivity measurements and an apparent I.P. data. The files IPMODEL.DAT, IPMAGUSI.DAT, IPSHAN.DAT and IPKENN.DAT are example data files with both resistivity and I.P. data. This program supports four different types of I.P. data; (i) time domain chargeability measurements, (ii) frequency domain percent frequency effect measurements, (iii) phase angle measurements and (iv) metal factor I.P. values.

The file IPMODEL.DAT has the I.P. data as chargeability values using the index based format for the positions of the electrodes. The first part of the file with comments is listed in Table 17. A value of "1", instead of "0", is entered into the sixth line to indicate that I.P. data is present. This is followed by 3 data lines that give information about the nature of the I.P. data. The seventh line with the word 'Chargeability' shows that the I.P. data is given in terms of chargeability. Many I.P. instruments measured the chargeability by integrating the area under the I.P. decay curve. In this case, the unit is in msec (millisecond). The chargeability value obtained by this method is normally calibrated to the Newmont $M_{(331)}$ standard (Summer 1976) so that the chargeability value in msec has the same numerical value as the chargeability given in mV/V. The chargeability in mV/V is defined as the ratio of the secondary voltage immediately after the current is cut off to the primary DC voltage.

Table 17. Example data file with I.P. values as chargeability.

<i>IPMODEL.DAT file</i>	<i>Comments</i>
Fault and block model	<i>Name of survey line</i>
1.0	<i>Unit electrode spacing</i>
3	<i>Array type (3 for dipole-dipole)</i>
432	<i>Number of data points</i>
1	<i>1 indicates center of array is given</i>
1	<i>1 to indicate IP present</i>
Chargeability	<i>Type of I.P. data</i>
msec.	<i>I.P. unit</i>
0.1,1.0	<i>Delay, integration time</i>
1.50 1.00 1 12.04 7.2038	<i>1st data point : - x-loc., a, n, app. res., app. IP</i>
2.50 1.00 1 12.03 7.1983	<i>2nd data point</i>
..	
..	<i>Same format for other data points</i>
..	

I.P. surveys have traditionally been used in the mineral exploration industry, particularly for metal sulfides, where generators producing high currents of the order of 10 Amperes are used. The apparent I.P. values from such surveys are usually less than 100 msec. (or mV/V). One recent development is the addition of IP capability to battery based systems used in engineering and environmental surveys where currents of 1 Ampere or less are normally used. An accompanying phenomenon is the observation of I.P. values of over 1000 msec. (or less than -1000 msec.) in some data sets. Such values are almost certainly caused by noise due to a very weak I.P. signal. To check whether such high I.P. values are real, first check the apparent resistivity pseudosection. If it shows unusually high and low values that vary in an erratic manner, the data is noisy. If the apparent resistivity values are noisy, then the apparent I.P. values are almost certainly unreliable. Next check the apparent I.P. pseudosection. If the apparent I.P. values show an erratic pattern (frequently with anomalous values lined up diagonally with an apex at a doubtful electrode), then the I.P. values are too noisy to be interpretable.

I.P. values that are given in other units are converted into chargeability values internally by the program during the inversion process. The relevant conversion equations may be found in the papers by Van Voorhis et al. (1973) and Nelson and Van Voorhis (1973). For frequency domain measurements, the I.P. value is usually given in Percent Frequency Effect (PFE). This is given as

$$\text{PFE} = 100 (\rho_{\text{DC}} - \rho_{\text{AC}}) / \rho_{\text{AC}} \quad (7.6)$$

where ρ_{DC} and ρ_{AC} are the apparent resistivity values measured at low and high frequencies. The file IPSHAN.DAT is an example of a frequency domain I.P. data set. In the seventh line, the type of I.P. data is given as "Percent Frequency Effect". The 9th data line contains the values of the low and high frequencies used in the measurement. This data set is from a field survey in Burma where the measurements were made with 20 and 40 meter dipoles (Edwards 1977). Like many field data sets, it has a very complex distribution of the data points in the pseudosection. The survey target is a galena deposit in meta-sediments. The geology is rather complex with massive galena deposits together with quartz veins, silicified marbles and clay zones. There is a very wide range of resistivity values.

I.P. values are also given as phase angles. In this case the unit normally used is milli-radians (mrad). An example of an I.P. data set with phase angles is given in the file IPKENN.DAT with values from the paper by Hallof (1990). In the seventh line, the type of I.P. data type is given as "Phase Angle". The second parameter in the ninth data line contains the values of the frequency at which the phase angles were measured. The first parameter is not used and is normally set to 0. Many modern I.P. survey instruments can measure the phase angle for several frequencies. In this case, the inversion of is repeated for the phase angle data at each frequency. This will give an idea of the change of the subsurface I.P. phase angle with frequency for complex resistivity studies.

I.P. data is sometimes given as a metal factor (MF) value. The MF value can be calculated from either time domain or frequency domain measurements. In the time domain, the metal factor is value is given by

$$MF = 1000 M / \rho_{DC} \quad (7.7)$$

where the chargeability M is given in terms of millisecond (Witherly and Vyselaar 1990). In the frequency domain, it is given as

$$MF = 100000 (\rho_{DC} - \rho_{AC}) / \rho_{AC}^2 \quad (7.8)$$

The file IPMAGUSI.DAT is from a survey over the Magusi River ore body (Edwards 1977) where the survey was conducted with 30.5 meter (100 feet), 61.0 meter (200 feet) and 91.4 meter (300 feet) dipoles. Again, the resulting pseudosection has a very complex distribution of the data points. The measured apparent resistivity and I.P. pseudosections, together with the model sections obtained are shown in Figure 14. The ore body shows up as a distinct low resistivity body with high IP values near the middle of the survey line in the model sections. In the inversion of this data set, the robust inversion (L1-norm) method was used (see section 11.2.1) to sharpen the boundary between the ore body and the surrounding rocks. This program uses the complex resistivity method (Kenma *et al.* 2000) for the inversion of I.P. data.

The inversion program tries to minimize the difference between the observed and calculated equivalent apparent chargeability values. IP values in percent frequency effect and phase angles are directly proportional to the equivalent chargeability values. However, the metal factor value also involves a resistivity value. The model that gives a minimum RMS error for the chargeability values sometimes does not give a minimum RMS error for the metal factor values. However, the actual effect on the inversion model is usually very small.

The file IPGENERAL8.DAT is an example I.P. data file using the general array data format. The I.P. data parameters are also given just before the main data section with the apparent resistivity and I.P. values.

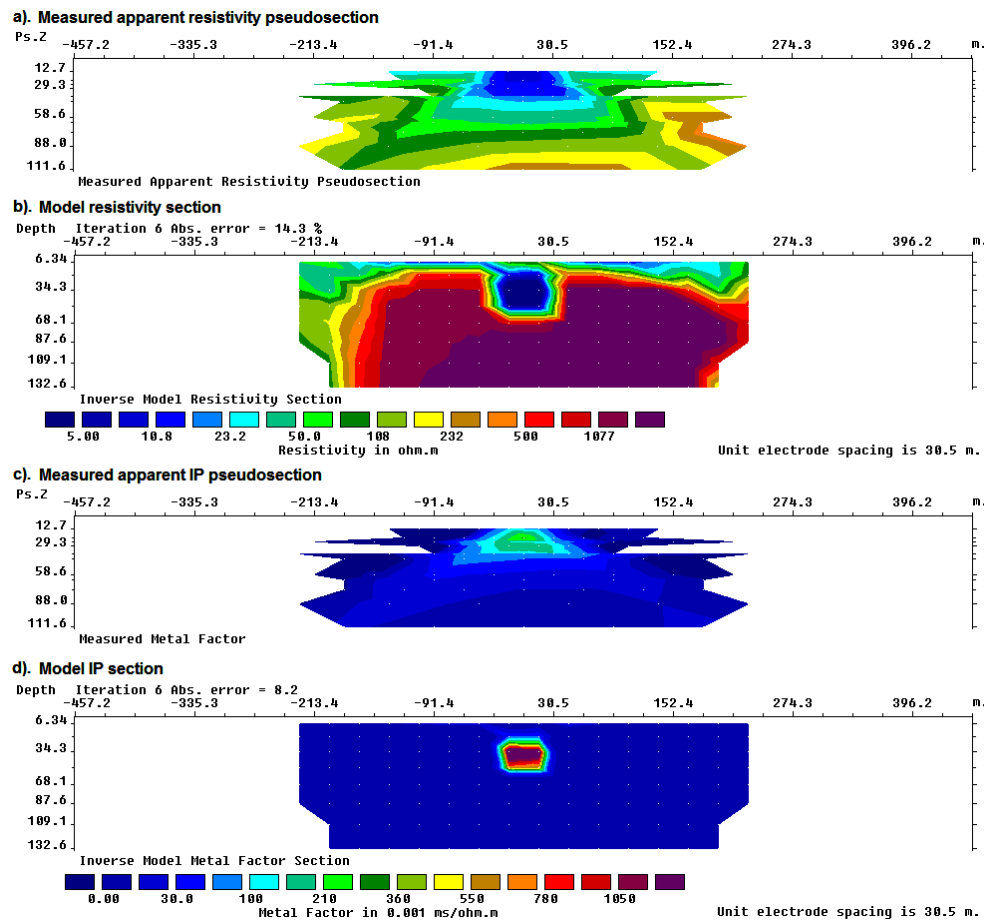

Figure 14. Magusi River ore body resistivity and I.P. sections. (a) Apparent resistivity pseudosection, (b) resistivity model section, (c) apparent metal factor pseudosection and (d) metal factor model section.

7.6 Time-lapse data files

In studying the changes of the subsurface resistivity with time, two-dimensional resistivity imaging surveys are often repeated over the same line at different times. Such studies include the flow of water through the vadose zone, changes in the water table due to water extraction (Barker and Moore 1998), flow of chemical pollutants and leakage from dams.

The file TIMELAPS.DAT is an example data file with three sets of apparent resistivity data. The upper part of the file together with comments about the data format is listed in Table 18. The data format is largely similar to the normal data set with only one set of readings. For a time-lapse data file, the main difference is the extra section just before the data block with the apparent resistivity values. Here the header "Time sequence data" is used to indicate the presence of the extra data sets corresponding to the later time measurements. The following part of this extra section contains information on the number of time series measurements (3 in this example). The maximum number of time series data sets allowed is 21 (30 for RES2DINVx64 with 16GB RAM). For each data point, the format for the initial part is identical to that used for the normal data sets. The only addition is that after the apparent resistivity value for the first data set, the corresponding apparent resistivity values for the later time data sets are given.

Table 18. Example time-lapse data set with 3 time series.

<i>TIMELAPS.DAT file</i>	<i>Comment</i>
Example time-lapse data	<i>Title</i>
1.0	<i>Unit electrode spacing</i>
7	<i>Array type, Wenner-Schlumberger in this example</i>
350	<i>Number of data points</i>
1	<i>Mid-point of x-location of array is given</i>
0	<i>No I.P. data</i>
Time sequence data	<i>Header to indicate time-lapse data</i>
Number of time sections	<i>Header</i>
3	<i>Number of time series</i>
Time unit	<i>Header</i>
Hours	<i>Unit used in time measurement</i>
Second time section interval	<i>Header</i>
1.0	<i>Time difference for second time data set</i>
Third time section interval	<i>Header</i>
2.0	<i>Time difference for third time data set</i>
1.50 1.00 1.0 11.868 11.868 11.868	<i>The format for each datum point is as follows :</i>
2.50 1.00 1.0 11.867 11.867 11.867	<i>x-location, "a" electrode spacing, "n" factor,</i>
3.50 1.00 1.0 11.863 11.863 11.863	<i>apparent resistivity for first data set, apparent</i>
4.50 1.00 1.0 11.859 11.860 11.860	<i>resistivity for second data set,</i>
5.50 1.00 1.0 11.855 11.856 11.856	<i>apparent resistivity for third data set.</i>
6.50 1.00 1.0 11.851 11.851 11.851	
...	<i>Same format for other data points</i>

If a measurement was missing from a time series, enter 0.0 as the value of the apparent resistivity for that particular time series. The program will assume that a zero value is an indication of a missing data point.

7.7 Incorporating data noise estimates

Some types of resistivity surveying instruments record an estimate of the random noise for each measurement. This is usually made by repeating the same measurement several times. The data error estimate is then calculated from the standard deviation in the readings. This actually gives a measure of the repeatability in the readings, i.e. the random noise. Note that this data error estimate does not include sources of systematic errors such as coupling between the cables. A better method to estimate the data error is by using reciprocal measurements.

To include the data error estimate in a data file, the error values are entered after the apparent resistivity value. The file MODEL35_N.DAT is an example of a data file from a surface survey with the error values. Part of the file is shown in Table 19 with an explanation of the changes needed. Note there are two new additions in the data format. Firstly, just before the section of the file with the measured apparent resistivity data points, there are 3 extra lines. The first line 'Error estimate for data present' is a header to indicate that the data file contains the data error estimates. The second new line is a header to explain the use of the next line. The third line contains a flag to indicate to the program the units used in the error estimate. At present, use a value of '0' to indicate that the error value has the same units as the data value. For example, if the measurements are given as ohm.m, then the error values must also be in ohm.m. Measurements in most instruments are given as resistance values (i.e. ohm), or voltage plus current values which can be converted to resistance values. To calculate the apparent resistivity value, the resistance value is multiplied by a geometric factor. The error value recorded by the instrument is probably in the form of a resistance (ohm) value. Thus, the error estimate recorded by the instrument must also be multiplied by the same geometric factor before it is entered into the DAT file format used by this program. The file modelip_5%_noise.dat gives an example of an I.P. data set with noise estimates. The use of the flag for the unit used by the error value makes it possible for future versions of the program to allow the use of other units for the error value, for example the data in ohm.m while the error in ohm. Another possibility is the error given as a percentage value.

Table 19. Example data file with noise estimates.

<i>MODEL35_N.DAT file</i>	<i>Comments</i>
Block Model	<i>Title</i>
1.00	<i>Unit electrode spacing</i>
7	<i>Array type, 7 for Wenner-Schlumberger</i>
230	<i>Number of data points</i>
1	<i>Mid-point of x-location of array is given</i>
0	<i>No I.P. data</i>
Error estimate for data present	<i>Header to indicate error values present</i>
Type of error estimate (0=same unit as data)	<i>Header for type of error</i>
0	<i>0 to indicate it is same unit as data vaue</i>
1.500 1.000 1.000 10.0145 0.1434	<i>x-loc., 'a' value, 'n' value, apparent resistivity, data point error value</i>
2.500 1.000 1.000 9.9706 0.1882	
3.500 1.000 1.000 10.3357 0.1761	
..	
..	<i>Other data points follow same format</i>
..	

To invert data with noise estimates, the least-squares equation in (4.1) is modified to the following equation

$$\left(\mathbf{J}^T \mathbf{W}_d^T \mathbf{W}_d \mathbf{J} + \mu \mathbf{F}\right) \mathbf{d} = \mathbf{J}^T \mathbf{W}_d^T \mathbf{W}_d \mathbf{g} - \mu \mathbf{F} \mathbf{q}_k \quad (7.9)$$

where \mathbf{w}_d is a diagonal weighting matrix that incorporates the effect of the data errors. Data points with a smaller error are given a greater weight in the inversion process. In an ideal situation, the noise estimate should be measured (for example by reciprocal measurements). However, in most field surveys such

noise estimates are not measured due to time constraints. In such a situation, the best option is probably to use the ‘Robust data constraint’ option (section 11.2.1) so that the effect of outliers in the data on the inversion model is minimized. With this option, a linear weight is given to the difference between the measured and calculated apparent resistivity values. This makes the inversion result less sensitive to outliers compared to the normal least-squares constraint where the square of the difference between the measured and calculated apparent resistivity values is used.

7.8 Fixing resistivities

In some cases, the true resistivity of a section of the subsurface might be known, for example from borehole resistivity measurements. This program allows you to fix the resistivity of up to 1000 sections of the subsurface. The shape of the section to be fixed must be rectangular or triangular. The data to fix the model resistivity values are entered into the input data file after section with the topography information.

As an example, part of the example data file MODELFIX.DAT is listed Table 20. The first item after the topography data section is the number of regions where the resistivity is to be specified. In the example above, 2 regions are specified. If a value of 0 is given (default value), then there are no regions where the resistivity is specified by the user. Next, the shape of the region is given, R for rectangular or T for triangular. If a rectangular region is specified, then the X and Z coordinates of the top-left and bottom-right corners of the rectangle are given, as shown in Figure 15.

Table 20. Example data file with fixed regions.

<i>MODELFIX.DAT file</i>	<i>Comments</i>
25.0 10.0 12.81	<i>Last data point</i>
0	<i>Topography flag, 0 for no topography</i>
2	<i>Number of regions to fix, put 0 if none</i>
R	<i>Type of first region, R for rectangular</i>
24,0.7	<i>X and Z coordinates of top-left corner of rectangle</i>
28,2.3	<i>Coordinates of bottom-right corner of rectangle</i>
2.0	<i>Resistivity value of rectangular region</i>
2.0	<i>Damping factor weight</i>
T	<i>Type of second region, T for triangular</i>
30,0.0	<i>X and Z coordinates of first corner of triangle</i>
30,3.0	<i>X and Z coordinates of second corner of triangle</i>
45,3.0	<i>Coordinates of third corner of triangle</i>
10.0	<i>Resistivity value of triangular region</i>
2.5	<i>Damping factor weight</i>
0,0,0	<i>Ends with a few zeros for other options</i>

If a triangular region is chosen, the X and Z coordinates of the 3 vertices of the triangle must be given in an anti-clockwise order. After the coordinates of the region to be fixed are given, the next data item is the resistivity of the region. After that, the damping factor weight for the resistivity of the region is needed. This parameter allows you control the degree in which the inversion subroutine can change the resistivity of the region. There is usually some degree of uncertainty in resistivity of the region. Borehole measurements can only give the resistivity of a very limited zone near the borehole. Thus, it is advisable that the program should be allowed (within limits) to change the resistivity of the region. If a damping factor weight of 1.0 is used, the resistivity of the region is allowed to change to the same extent as other regions of the subsurface model. The larger the damping factor weight is used, the smaller is the change that is allowed in the resistivity of the "fixed" region. Normally, a value of about 1.5 to 2.5 is used. If a relatively large value is used, for example 10.0, the change in the resistivity of the region would be very small during the inversion process. Such a large value should only be used if the resistivity and shape of the region is accurately known.

Fixing model resistivities

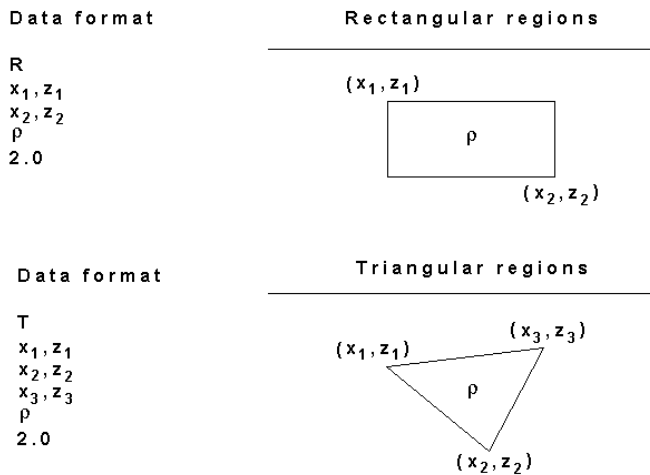

Figure 15. Fixing the resistivity of rectangular and triangular regions of the inversion model.

7.9 Aquatic surveys

(a) Single water layer

The possible situations for aquatic surveys are shown in Figure 16. In ‘Case 1’ all the electrodes are on the surface of the river or sea bottom and are underwater. In ‘Case 2’ the water layer covers a limited region and the ground rises above the water surface at some places, such as a survey across a river. In ‘Case 4’ the water region is limited by a barrier such as a dam wall or levee, and although the electrodes on the right side are below the water surface level, it is known that they are not covered by the water layer. ‘Case 3’ is for a survey with the electrodes floating on the water surface, such as on a streamer pulled by a boat. ‘Case 5’ is variation of this type of survey where the electrodes are on a streamer suspended between the surface and the bottom. This places the electrodes closer to the sub-bottom which is being surveyed but is not dragged along the bottom (as in ‘Case 1’) where it could encounter obstacles.

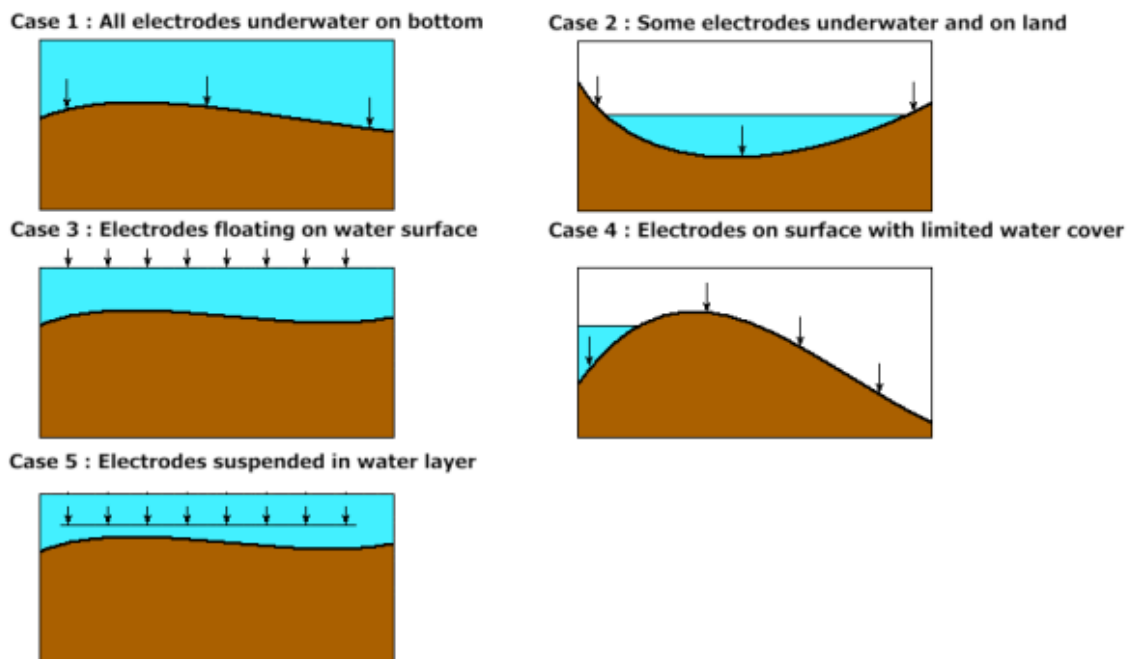

Figure 16. Five possible situations for aquatic surveys.

The information with the aquatic survey parameters are entered in the data file after the main section with the apparent resistivity data, topography and fixed regions.

7.9.1 Underwater surveys

The data format for surveys with electrodes planted on the water bottom for both cases 1 and 2 are the same. An example data file is HAT_HEAD.DAT that uses the index based format is listed in Table 21. Note that a flag is included to indicate that the normal geometric factor (as used for a surface survey) is used to calculate the apparent resistivity values. If a value of 0 is used for this flag, the exact geometric factor (which includes the thickness of the water layer) must be used to calculate the apparent resistivity values. In the HAT_HEAD.DAT file, some of the electrodes are above the water (Figure 17). In most surveys, all the electrodes are underwater as in the following LAKELELIA.DAT example (Table 22). The program will automatically calculate the thickness of the water layer from the elevation of the sea or river bottom and the elevation of the water surface. This format allows for the second situation shown in Figure 17 where some of the electrodes are above the water surface (i.e. on normal dry land) and some of the electrodes underwater. A common situation where this occurs is a survey that crosses a river. In this case, the program will assume that an electrode with an elevation that is less than the elevation of the water surface is underwater. For the case when some of the electrodes are above the water surface, the surface geometric factor must be used for calculating the apparent resistivity values for all the data points. The topographic modelling is automatically carried out by the program when you invert the data set. The program will automatically adjust the surface of the finite-element grid used to model the subsurface so that it matches the surface of the sediment below the water layer. Figure 18 shows the apparent resistivity pseudosection and inversion model for the LAKELELIA.DAT data set where all the electrodes are underwater. Mobile surveying systems typically produce survey lines that are very long compared to the depth of investigation of the cable array system used.

Table 21. Example data file for aquatic survey with bottom electrodes.

<i>HAT_HEAD.DAT file</i>	<i>Comments</i>
LR5 Marine	<i>Title</i>
2.5	<i>Unit electrode spacing</i>
1	<i>Array type, Wenner in this example</i>
392	<i>Number of data points</i>
0	<i>First electrode x-location of array is given</i>
0	<i>No I.P. data</i>
0.0 2.5 20.445599	<i>First data point</i>
7.5 2.5 167.579387	<i>Second data point</i>
..	
..	<i>Same format for other data points</i>
..	
2.5 40 25.202095	<i>Last data point</i>
2	<i>Topography flag, surface distance used</i>
50	<i>Number of topography points</i>
0.0 2.36	<i>x-location and elevation of 1st topography point</i>
2.5 2.41	<i>x-location and elevation of 2nd topography point</i>
..	
..	<i>Same format for other topography points</i>
77.5 0.55	
80.0 0.00	<i>A few points below water surface</i>
82.5 0.05	
..	
122.5 2.51	<i>Last topography point</i>
1	<i>Indicates first electrode is at first topography data point</i>
0	<i>Flag for fixed regions, 0 for no fixed regions in this case</i>
1	<i>Flag to indicate aquatic survey with bottom electrodes</i>
0.18	<i>Resistivity of water layer</i>
0, 122.5	<i>Left and right limits of water layer</i>
1.5	<i>Elevation of water surface</i>
1	<i>1 to indicate normal surface geometric factor used</i>
0,0,0	<i>Ends with a few zeros for other options</i>

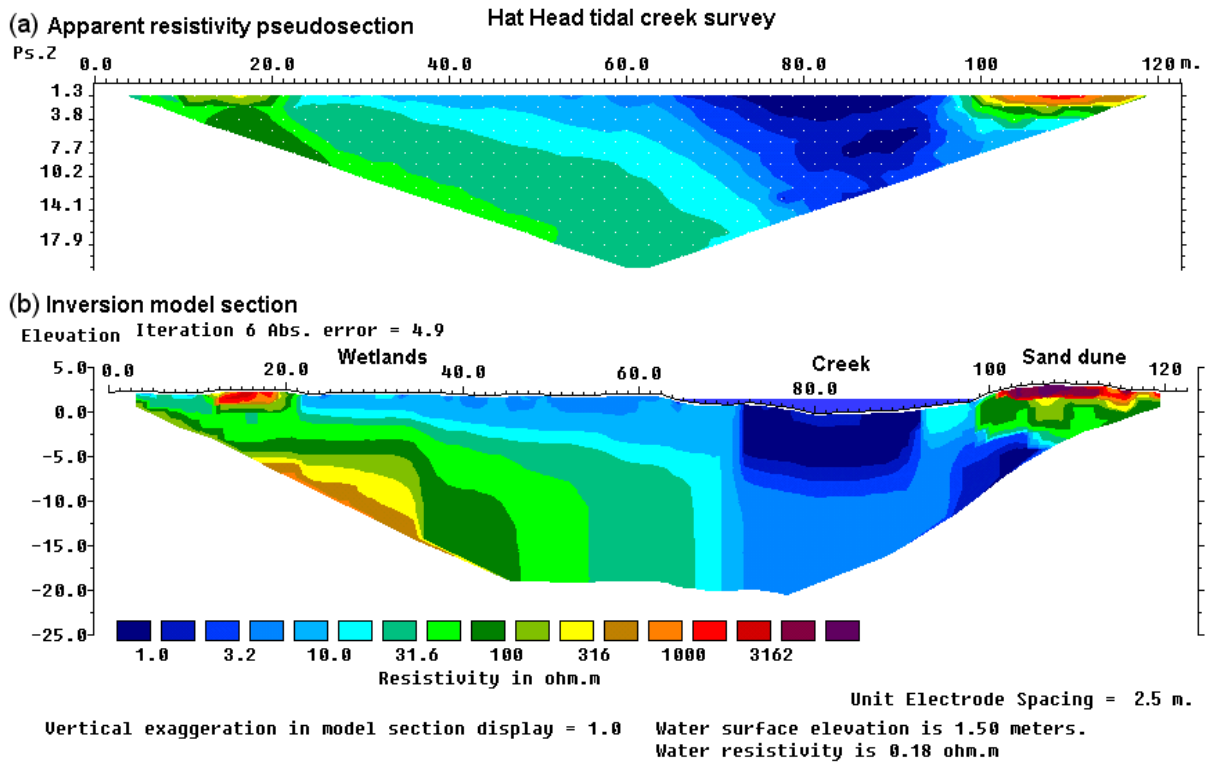

Figure 17. Hat Head land and underwater survey. (a) Apparent resistivity pseudosection (Wenner array) from the Hat Head tidal creek survey and (b) the inversion model. Note the creek between the 65 and 95 meters marks where the electrodes are underwater.

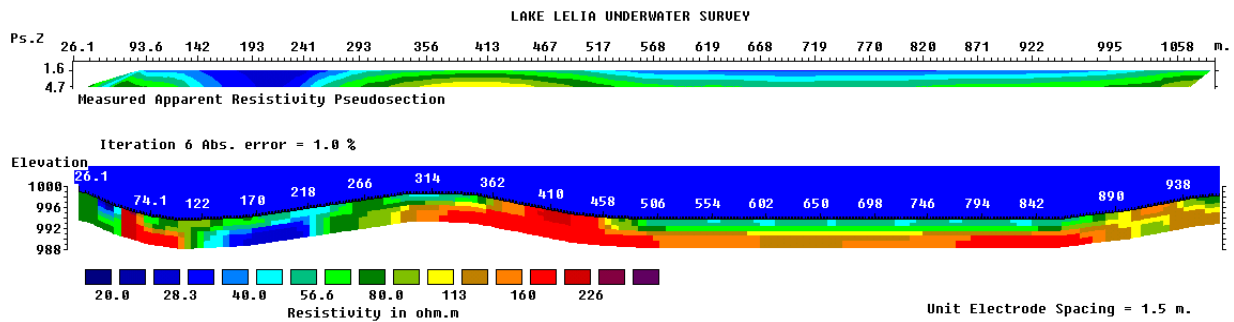

Figure 18. Lake Lelia underwater survey apparent resistivity pseudosection and model resistivity section. Courtesy of Technos Inc., USA.

Table 22. Underwater survey data file in general array format.

<i>LAKELELIA.DAT file</i>	<i>Comments</i>
LAKE LELIA UNDERWATER SURVEY	<i>Title</i>
1.50	<i>Unit electrode spacing</i>
11	<i>General array type</i>
1	<i>Wenner sub-array</i>
Type of measurement (0=app. resistivity.1=resistance)	<i>Header</i>
0	<i>0 to indicate apparent resistivity given</i>
291	<i>Number of data points</i>
2	<i>Indicates surfaces x-distances</i>
0	<i>No I.P. data</i>
4 82.37,0.0 91.37,0.0 85.37,0.0 88.37,0.0 43.137	<i>First 4 data points in general</i>
4 89.55,0.0 98.55,0.0 92.55,0.0 95.55,0.0 36.599	<i>array data format. Note</i>
4 96.74,0.0 105.74,0.0 99.74,0.0 102.74,0.0 36.458	<i>value of 0.0 for electrode</i>
4 103.92,0.0 112.92,0.0 106.92,0.0 109.92,0.0 37.019	<i>elevation as it is listed later.</i>
..	<i>Similar format for other data</i>
..	<i>points</i>
4 1050.25,0.0 1077.25,0.0 1059.25,0.0 1068.25,0.0 93.072	<i>Last 2 data points</i>
4 1056.35,0.0 1083.35,0.0 1065.35,0.0 1074.35,0.0 95.383	
Topography in separate list	<i>Header to indicate elevation is given separately</i>
2	<i>2 to indicate surface x-distances</i>
38	<i>Number of topography data points</i>
26.12 999.09	<i>Topography x and z values</i>
..	
..	
1127.76999.09	
1	<i>First electrode coincides with first topography data point</i>
0	<i>Put 0 here in place of usual topography data</i>
0	<i>0 for no fixed regions</i>
1	<i>1 indicates underwater survey</i>
58.00	<i>Resistivity of water layer</i>
-2000.00,2000.00	<i>Left and right limits of water layer</i>
1000.0	<i>Elevation of water surface</i>
1	<i>Indicates surface geometric factor used for apparent resistivities</i>
0,0,0,0	<i>End with a few zeros</i>

A possible situation where the water layer has a limited extent is shown as ‘Case 4’ in Figure 16. In this example the water is limited to the left side and is blocked by a barrier. Although some electrodes on the right side are below the water surface level, they are not covered by the water layer. Any electrode which is located outside the left and right limits of the water layer specified in the data file is assumed to be not covered by the water. An example data file is the DAM_SURVEY.DAT file (Table 23).

Table 23. Survey across a dam with only electrodes on the dam side underwater.

<i>DAM_SURVEY.DAT file</i>	<i>Comments</i>
Survey across a dam	<i>Title</i>
5.0	<i>Unit electrode spacing</i>
7	<i>Wenner-Schlumberger array type</i>
3025	<i>Number of data points</i>
0	<i>Indicates first electrode position given</i>
0	<i>No I.P. data</i>
0.0000, 5.0000, 1.00000, 13.2933	<i>First 4 data points in general</i>
5.0000, 5.0000, 1.00000, 11.5155	<i>array data format. Note</i>
10.0000, 5.0000, 1.00000, 10.4964	<i>value of 0.0 for electrode</i>
15.0000, 5.0000, 1.00000, 9.8681	<i>elevation as it is listed later.</i>
..	<i>Similar format for other data points</i>
540.0000, 5.0000, 1.00000, 24.8984	
..	
10.0000, 5.0000, 54.00000, 18.2645	<i>Last 2 data points</i>
0.0000, 5.0000, 55.00000, 18.1088	
2	<i>2 to indicate surface x-distances</i>
112	<i>Number of topography data points</i>
0.0000, 30.0000	<i>Topography x and z values</i>
..	
..	
555.0000, 0.0000	<i>Last topography point</i>
1	<i>1st electrode coincides with 1st topography data point</i>
0	<i>0 for no fixed regions</i>
1	<i>1 indicates underwater survey</i>
20.00	<i>Resistivity of water layer</i>
0.0,130.0	<i>Left and right limits of water layer, note right limit of 130.0 is less than length of line</i>
71.5000	<i>Elevation of water surface</i>
1	<i>Indicates surface geometric factor used for apparent resistivities</i>
0,0,0,0	<i>End with a few zeros</i>

Note in the above table, the right limit of the water layer (130.0 m) is much less than the right end of the line at 555.0 m. When the program reads in such a file where the limits of the water layer is less than the line coverage, it will automatically detect such a situation and display a ‘Water layer has limited extent’ message and set the proper inversion settings.

Another possible situation is shown in Figure 16 (case 5) where the electrodes are on a streamer suspended between the water surface and the bottom. The data format for this case is described in Appendix D.

(b) Stratified water layer

In areas near the coast, the water layer resistivity might have a significant variation with depth. A common situation that arises is a freshwater (higher resistivity) layer overlying a denser more saline (lower resistivity) near the bottom. In some surveys the depth to the water bottom might change significantly along the survey line that makes it important to include the variation of the water resistivity with depth in the model. The example file water-2-layers-diff-a6-n6.dat (Table 24) shows the data format used when there is more than one water layer. Note the slight change in the data format in the bottom section of the file to accommodate more than one water layer. It is assumed that the boundary between

the layers is always horizontal. The program allows up to a maximum of 12 water layers that should be sufficient to model almost any water resistivity variation with depth. A field example where it was necessary to use more than 5 water layers to accurately model the water resistivity variation with depth in a survey across a river is described in Dahlin *et al.* (2014).

Table 24. Underwater survey data file with two water layers.

<i>water-2-layers-diff-a6-n6.dat file</i>	<i>Comments</i>
Model with two water layers	<i>Title</i>
1.00	<i>Unit electrode spacing</i>
3	<i>Dipole-dipole array type</i>
1143	<i>Number of data points</i>
1	<i>Indicates array mid-point given</i>
0	<i>No I.P. data</i>
1.500 1.000 1.000 32.0955	<i>First 2 data points</i>
3.500 1.000 1.000 32.2777	
..	<i>Similar format for other data</i>
..	<i>Points</i>
25.000 6.000 6.000 87.8598	<i>Last 2 data points</i>
26.000 6.000 6.000 87.6574	
2	<i>Topography flag 2 to indicate surface x-distances</i>
3	<i>Number of topography data points</i>
0.000, -4.000	<i>Topography x and z values</i>
25.500, -4.001	
50.000, -4.000	
1	<i>First electrode coincides with first topography data point</i>
0	<i>0 for no fixed regions</i>
Number of water layers	<i>Header to indicate more than 1 water layer</i>
2	<i>Shows 2 layers</i>
Layer 1 parameters	<i>Header for first water layer</i>
80.000,-100.000, 200.000,0.000	<i>Resistivity, left and right limits of water layer, elevation at top of water layer</i>
Layer 2 parameters	<i>Header for second water layer</i>
50.000,-100.000, 200.000, -1.620	<i>Resistivity, left and right limits of water layer, elevation at top of 2nd water layer</i>
1	<i>Indicates surface geometric factor used for apparent resistivities</i>
0,0,0,0	<i>End with a few zeros</i>

7.9.2 Surveys with floating electrodes

Another possible arrangement for an aquatic survey is a boat dragging a cable with the electrodes floating on the water surface. The main disadvantage of this arrangement is that a large part of the current flows within the water layer, compared to the portion of the current that flows into the material below the water bottom. The main advantage is that the survey is easier and faster to carry out and avoids problems such as the cable being snagged by obstacles on the river bottom. It could be an efficient method in shallow areas where the screening effect due to the water layer is not too large.

One possible way of interpreting such a data set is to treat it as a standard surface data set where the water layer is included as part of the model. This probably gives acceptable results where there is a strong contrast between the water layer and the topmost layer of the sub-bottom materials, and where the data has a low noise level.

However, if the depth of the water bottom was measured during the course of the survey (usually with an echo sounder), and the water resistivity was also measured, the effect of the water layer could be calculated and included in the model. The file WATER_FLOAT.DAT is a synthetic data set which gives an example of the data format. The initial part of the file is identical with that used for normal surface surveys or surveys with electrodes on the water bottom. The difference is in the final section of the file where the water layer parameters are given in Table 25. While this example gives the data in the general array format (section 7.2), the program can also accept data in the index based format (section 7.1). Most

systems for surveys with floating electrodes take measurements at a finer spacing compared to the spacing between the electrodes takeouts on the cable. Please refer to section 8.2 for methods to handle such data from mobile survey systems.

As a final note, it has been observed that in some data sets there is mismatch between the coordinates of the electrodes for the measurements and the bottom topography as measured using a profiler and a GPS system. This shows up when using the option to incorporate the water layer in the inversion model by a horizontal shift (usually of 5 to 10 meters) between the bottom topography and steep structures in the inversion model such as small gullies and peaks. This is probably due to differences in the locations of the depth sounder system and the cable with the electrodes.

In a 2-D data file, it is assumed that the survey line is straight. This might be difficult in some areas with strong water currents. If there are significant deviations in the direction of the line, it might be better to use the Res3dinvx64 program to treat the survey as a 3-D data set.

Table 25. Survey data file with floating electrodes.

<i>WATER_FLOAT.DAT file</i>	<i>Comments</i>
Survey on water layer and floating electrodes	<i>Title</i>
2.0	<i>Unit electrode spacing</i>
11	<i>General array type</i>
0	<i>Non-specific sub-array</i>
Type of measurement (0=app. resistivity.1=resistance)	<i>Header</i>
0	<i>0 to indicate apparent resistivity given</i>
942	<i>Number of data points</i>
1	<i>Indicates true horizontal x-distances</i>
0	<i>No I.P. data</i>
4 2.0,0.0 0.0,0.0 4.0,0.0 6.0,0.0 1.86738	<i>First 3 data points in general</i>
4 4.0,0.0 2.0,0.0 6.0,0.0 8.0,0.0 1.86843	<i>array data format. Note water</i>
4 6.0,0.0 4.0,0.0 8.0,0.0 10.0,0.0 1.87070	<i>surface at 0.0 meter elevation</i>
..	
..	<i>Similar format for other data</i>
..	<i>points</i>
4 46.0,0.0 34.0,0.0 94.0,0.0 106.0,0.0 14.91776	<i>Last 2 data points</i>
4 48.0,0.0 36.0,0.0 96.0,0.0 108.0,0.0 15.51526	
0	<i>No topography information</i>
0	<i>No fixed regions</i>
3	<i>3 indicates floating electrodes survey</i>
Water resistivity	<i>Header</i>
1.5	<i>Water resistivity value</i>
Water elevation	<i>Header</i>
0.0	<i>Elevation of water surface</i>
18	<i>Number of water bottom depth points</i>
0 -1.5	<i>x-location and elevation of water</i>
10 -1.5	<i>bottom below water surface given</i>
20 -1.5	<i>for each point</i>
26 -1.5	
28 -2.0	
30 -2.5	
..	
..	<i>Similar format for other points</i>
..	
108 -1.5	<i>last depth point</i>
1	<i>Indicates first electrode is at first depth point</i>
0,0,0,0	<i>End with a few zeros</i>

7.10 Incorporating boundaries of known layers

In some cases, the depth profile of a boundary between two layers with very different resistivity values is known from other sources; such as borehole data, seismic refraction or GPR surveys. Very frequently, there is a rapid and sharp change across the boundary, such as between a clay and sand layer. If the depth to the boundary is known, this information can be incorporated into the inversion so that the resistivities of the layers can be more accurately determined.

The file CLIFLAYER4.DAT is an example data file where the boundary between a gravel and underlying clay layer is known from a seismic refraction survey (Scott *et al.* 2000). Part of the file is shown in Table 26 with an explanation of the changes needed. In this example there are two boundaries. The program allows up to 30 boundaries that should be sufficient for almost all practical cases. The file MODEL_BOUNDARY_GENERAL.DAT gives an example of a data file with the general array format with only one boundary. Figure 19 shows the inversion of the CLIFLAYER4.DAT data set using different inversion options. The first model using the smooth inversion method (section 11.2) shows a gradational transition between the sand and underlying lower resistivity clay layer (Figure 19b). The depth to the boundary is not well determined. The use of the blocky or robust inversion method (section 11.2) gives a much sharper boundary (Figure 19c). The addition of the boundary from the seismic refraction survey helps to further sharpen the boundary (Figure 19d).

The greatest limitation of this option at present is that the depths to the layers are fixed throughout the inversion. An option to allow the depths to be automatically changed might be added in a future update.

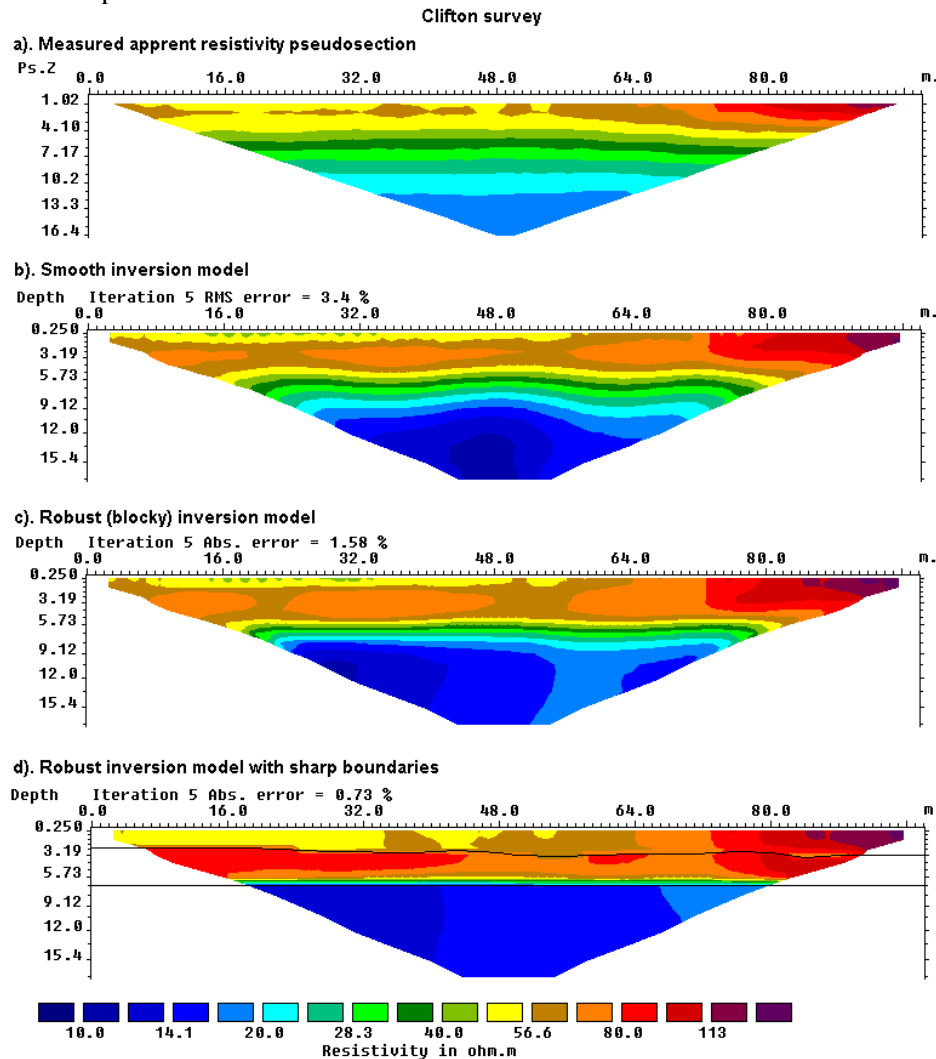

Figure 19. Models for the Clifton survey from the different inversion methods are shown together. Note the boundary between the high resistivity sand layer and the underlying low resistivity clay layer is much better resolved in the blocky and sharp boundary inversion methods.

Table 26. Example survey data file with known boundaries.

<i>CLIFLAYER4.DAT file</i>	<i>Comments</i>
Clifton	<i>Title</i>
2	<i>Unit electrode spacing</i>
1	<i>Indicates Wenner array</i>
392	<i>Number of data points</i>
1	<i>Type of x-location (center)</i>
0	<i>No I.P.</i>
3 2 58.63305	<i>First data point in index based format</i>
5 2 56.77204	<i>Second data point</i>
..	
..	<i>Other data points</i>
50 32 17.94035	<i>Last data point</i>
0	<i>No topography</i>
0	<i>No fixed regions</i>
0	<i>No aquatic survey</i>
Sharp layers present	<i>Header to indicate sharp boundaries present</i>
Number of boundaries	<i>Header</i>
2	<i>Number of boundaries, two in this case</i>
Boundary 1 parameters	<i>Header for first boundary</i>
Boundary type	<i>Header for type of boundary</i>
Layer	<i>Layer type</i>
Group weight	<i>Header for weight, for future use</i>
1.0	<i>Enter 1.0 here, not used at present</i>
Number of points on boundary	<i>Header</i>
16	<i>16 points for this boundary</i>
x and z coordinates of pts	<i>Header</i>
0.0 2.3	<i>x-location and depth of 1st point</i>
18.0 2.3	<i>x-location and depth of 2nd point</i>
..	
..	<i>x-location and depth of other points</i>
..	
92.0 3.2	<i>x-location and depth of last point</i>
Boundary 2 parameters	<i>Header for second boundary</i>
Boundary type	<i>Header for type of boundary</i>
Layer	<i>Layer type</i>
Group weight	<i>Header for weight, for future use</i>
1.0	<i>Enter 1.0 here, not used at present</i>
Number of points on boundary	<i>Header</i>
3	<i>3 points for this boundary</i>
x and z coordinates of points	<i>Header</i>
0.0 6.7	<i>x-location and depth of 1st point</i>
45 6.7	<i>x-location and depth of 2nd point</i>
92 6.7	<i>x-location and depth of 3rd point</i>
0,0,0,0	<i>End with a few zeros</i>

7.10.1 Specifying and fixing resistivity of regions above and below a sharp boundary

In some special cases, the resistivity of the regions above and below the sharp boundary might be known or can be estimated. To estimate the resistivity, an inversion of the data set can be first carried out without the specifying the resistivity of the regions. A common situation is an insulating liner below a landfill. The material within the landfill can have relatively low resistivity values (such as about 100 ohm.m), and the main purpose of the survey is to map the resistivity variations in the landfill materials. The landfill liner might be essentially an insulating boundary where the current cannot penetrate through it, so the resistivity of the region below the liner can be considered more than several thousand ohm.m. This information can be incorporated into the inversion by specifying the depth profile of the liner and the resistivity of the region below it. The bottom part of an example data file is listed in Table 27. The 'Group Weight' value sets the damping factor for the region. A value of 1.0 means the resistivity is allowed to vary freely during the data inversion. A much higher value, such as 20.0, greatly reduces the variations allowed and essentially fixes the resistivity value. This ensures the resistivity of the selected region is kept fixed during the inversion, and in this example the program only changes the resistivity of the region above the boundary to fit the measured data.

Table 27. Example data file with sharp boundary and specified resistivity of regions above and below boundary.

<i>Sharp-Boundary-Resistivity.dat file</i>	<i>Comments</i>
21.00 6.00 5.00 325.20636	<i>Last</i>
22.00 6.00 5.00 317.22330	<i>three</i>
23.00 6.00 5.00 330.36230	<i>data points</i>
0	<i>Topography flag, 0=no topography</i>
0	<i>No fixed regions</i>
0	<i>No aquatic survey</i>
Sharp layers present	<i>Header to indicate sharp boundaries present</i>
Number of boundaries	<i>Header</i>
1	<i>1 boundary in this example</i>
Boundary 1 parameters	<i>Third coordinate point</i>
Boundary type	<i>Zeros to indicate other options,</i>
Layer	<i>such as fixed regions etc.</i>
Group Weight	
1.000	
Fix resistivity? (0=No,1=Yes)	
1	
Resistivity value	
100.0	
Number of points on boundary	
3	
x and z coordinates of points	
0.000, 4.740	
20.000, 4.741	
44.000, 4.740	
Fix resistivity of region below last boundary? (0=No,1=Yes)	
1	
Group Weight	
20.000	
Fix resistivity?	
1	
Resistivity value	
4000.0	
0,0,0,0	

7.11 Global or GPS coordinates

Two-dimensional resistivity surveys are carried out with the electrodes arranged along a straight line. The coordinates of the electrode positions, and thus the subsurface model resistivity values, are given with respect to the ends of the line in the form of local coordinates. In order to incorporate the results in a map, the true coordinates (in terms of latitudes and longitudes, or northings and eastings) are required. The positions of points along the line can now be easily obtained using Global Positioning System (GPS) receivers. In order to obtain the true coordinates for the model values, the GPS coordinates must first be entered into the data file read by the RES2DINV program. The results can later be extracted from the XYZ file generated from the data inversion file.

The information concerning the GPS coordinates is given in the section immediately after the topography information in the data file. An example for a data file (without topography) using the index based format for the resistivity data is given in the file BETA_GLOBAL.DAT. The section of the file containing the GPS information is shown in Table 28.

Table 28. Example data file with global coordinates.

<i>BETA_GLOBAL.DAT file</i>	<i>Comments</i>
8.750 4.500 10.132	<i>Last</i>
7.500 5.000 9.601	<i>three</i>
8.000 5.000 9.601	<i>data points</i>
0	<i>Topography flag, 0=no topography</i>
Global Coordinates present	<i>Header to indicate GPS information present</i>
Number of coordinate points	<i>Header</i>
3	<i>Number of coordinate points</i>
Local Longitude Latitude	<i>Header</i>
0.0 20.0 10.0	<i>First coordinate point given as Local position along line, GPS Longitude, GPS Latitude</i>
8.0 26.93 14.0	<i>Second coordinate point</i>
15.5 33.42 17.75	<i>Third coordinate point</i>
0	<i>Zeros to indicate other options,</i>
0	<i>such as fixed regions etc.</i>
0	<i>not present</i>

An example for a data file with topography using the index based format is given in the file RATCHRO_GLOBAL.DAT. The section of the file containing the GPS information given after the topography section is shown in Table 29. The file IP_MAGUSI_MF_GLOBAL.DAT is an example of a data file with IP values as well the GPS information.

The file MIXED_GLOBAL.DAT and RATHMIX_GLOBAL.DAT are examples of data files using the general array format containing GPS coordinates. Both data sets have the topography information within each data point line. The section of the RATHMIX_GLOBAL.DAT with the GPS information is shown in Table 30. The file LAKELELIA_GLOBAL.DAT is an example with data in the general array format for an underwater survey with GPS coordinates. It also has the topography information in a separate list from the apparent resistivity data lines. Part of this file is shown in Table 31.

To make use of the GPS coordinates, you need to first run an inversion of the data set. Next read the inversion file in the 'Display' window, and then save the model values in an XYZ file using the 'File - Model export - Save data in XYZ format' option (section 14.1.2). The model values with the GPS coordinates will be listed in the last section of the XYZ file.

Table 29. Example data file with index based format and topography and global coordinates.

<i>RATHCRO_GLOBAL.DAT file</i>	<i>Comments</i>
..	<i>Initial section with main data section and</i>
..	<i>topography</i>
..	
92,-3.207	<i>Last</i>
94,-3.27	<i>Three topography</i>
96,-3.34	<i>data points</i>
1	<i>First topography point same as first electrode</i>
Global Coordinates present	<i>Header to indicate GPS information present</i>
Number of coordinate points	<i>Header</i>
3	<i>Number of coordinate points</i>
Local Longitude Latitude	<i>Header</i>
-36.0 80100.0 200300.0	<i>First coordinate point given as Local position along line, GPS Longitude, GPS Latitude</i>
20.0 80148.1 200327.8	<i>Second coordinate point</i>
96.0 80213.3 200365.4	<i>Third coordinate point</i>
0	<i>Zeros to indicate other options,</i>
0	<i>such as fixed regions etc.</i>
0	<i>not present</i>

Table 30. Example data file with general array format, topography and global coordinates.

<i>RATHMIX_GLOBAL.DAT file</i>	<i>Comments</i>
...	<i>Initial part with main data section</i>
4 60.0 -0.093 96.0 -3.34 72.0 -2.274 84.0 -2.914 1680.0	<i>Last apparent resistivity data point</i>
0	<i>Put zero for topography flag</i>
Global Coordinates present	<i>Header to indicate GPS information present</i>
Number of coordinate points	<i>Header</i>
3	<i>Number of coordinate points</i>
Local Longitude Latitude	<i>Header</i>
-36.0 80100.0 200300.0	<i>Local position along line, GPS Longitude and Latitude</i>
20.0 80148.1 200327.8	<i>Second coordinate point</i>
96.0 80213.3 200365.4	<i>Third coordinate point</i>
0	<i>Zeros to indicate other options,</i>
0	<i>such as fixed regions etc.</i>
0	<i>not present</i>

Table 31. Example aquatic survey data file with global coordinates.

<i>LAKELELIA_GLOBAL.DAT file</i>	<i>Comments</i>
...	<i>Initial part with main data section</i>
Topography in separate list	<i>Header for topography information</i>
2	<i>Topography flag</i>
38	<i>Number of topography points</i>
26.12 999.09	<i>First topography point</i>
.....	<i>Other topography data points</i>
1127.76999.09	<i>Last topography point</i>
1	<i>1st topography point at 1st electrode</i>
Global Coordinates present	<i>Header to indicate GPS information present</i>
Number of coordinate points	<i>Header</i>
4	<i>Number of coordinate points</i>
Local Longitude Latitude	<i>Header</i>
26.0 100000.0 200000.0	<i>First coordinate point given as local position along line, GPS Longitude and Latitude</i>
126.0 100086.6 200086.6	<i>Second coordinate point</i>
500.0 100410.5 200237.0	<i>Third coordinate point</i>
1092.0 100923.2 200533.0	<i>Last coordinate point</i>
0	<i>Zeros to indicate other options,</i>
0	<i>such as fixed regions etc. not present</i>
1	<i>Indicates water layer present</i>
58.00,-2000.00,2000.00,1000,1	<i>The water layer information</i>
0,0,0	<i>End with a few zeros</i>

7.12 Extending the model horizontal range

The program automatically sets the left and right ends of the model at the first and last electrode locations for surveys with surface electrodes only. In some situations, there might be large resistivity contrasts just beyond the ends of the survey line. This option allows the user to extend the horizontal range of the inversion model used by the program. The data must be given in the general array data format (section 7.2) for this option to be used. The table below shows the data format using the example MIXEDWS_EXT2.DAT file.

Table 32. Example data file with extended model range.

<i>MIXEDWS_EXT2.DAT file</i>	<i>Comments</i>
Mixed array with extended model range	<i>Title</i>
1.0	<i>Unit electrode spacing</i>
11	<i>General array type</i>
7	<i>Sub-array type, Wenner-Schlumberger</i>
Type of measurement	<i>Header</i>
0	<i>Indicates apparent resistivity given</i>
Additional model blocks added beyond ends of survey line	<i>Header to indicate model extended beyond ends of line</i>
Number of additional blocks on both sides	<i>Header</i>
2	<i>Indicates 2 blocks added at both ends</i>
Positions of left additional blocks	<i>Header for left side</i>
-2.0,0.0	<i>x and z position of first extended point on left side</i>
-1.0,0.0	<i>x and z position of second extended point on left side</i>
Positions of right additional blocks	<i>Header for right side</i>
35.0,0.0	<i>x and z position of first extended point on right side</i>
36.0,0.0	<i>x and z position of second extended point on right side</i>
230	<i>Number of data points</i>
1	<i>True horizontal distance</i>
0	<i>No I.P. data</i>
4 0.0 0.0 19.0 0.0 9.0 0.0 10.0 0.0 10.644	<i>First data point</i>
4 1.0 0.0 20.0 0.0 10.0 0.0 11.0 0.0 10.281	<i>Second data point</i>
..	
..	<i>Same format for other data points</i>
0,0,0,0	<i>Ends with a few zeros for other options</i>

Note the format for the additional horizontal positions. Firstly, the x positions must be given starting from the left side, or the lowest value. The z positions must also be given. If there is no topography, a value of 0.0 is given as in the example. If there is topography, the elevation at the point must be given. The files RATMIX_Ext.dat and RATCMIX_Sep_Ext.dat are examples of the data format with topography.

8 File menu options

This covers the list of sub-options under the 'File' menu option, as shown below.

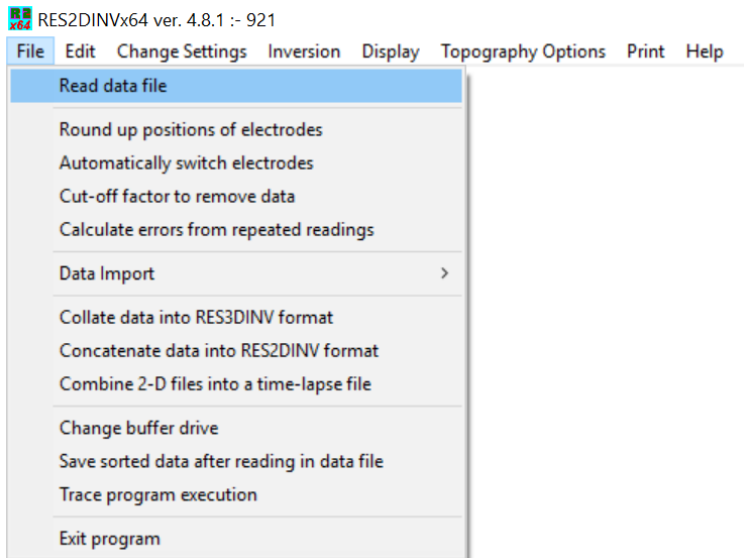

8.1 Read data file

This option reads in a data file which is in the RES2DINV DAT format (see section 7). It assumes the data is arranged in the format used by this program.

8.2 Round up positions of electrodes

This option is intended for data from long survey lines, particularly those collected using a mobile measuring system such as the Geometrics OhmMapper system or an aquatic surveying system such as the Iris Instruments Syscal Pro Deep Marine system. Such mobile surveying systems have a fixed spacing between the electrodes nodes in the cable, typically 5 meters or more. However, measurements are usually made at irregular intervals depending on the speed at which the cable is towed. Thus, the spacing between consecutive measurements do not have a fixed value and is usually less than the spacing between the electrode nodes on the cable. The positions of the measurements are usually measured with a GPS system. The processing software for some systems digitize the raw data collected to a fixed interval such as to the nearest 1 meter (i.e. rounds up the position of the electrodes to the nearest 1 meter), compared to the electrode takeouts on the cable that are 5 meters or more apart. The array probably cannot resolve such fine structures. A coarser discretization, such as to every 1.25 to 2.5 meters (i.e. one-quarter to half the spacing between the electrodes takeouts), is probably sufficient. This reduces the number of electrode positions in the inversion model, and consequently greatly reduces the inversion time without significantly affecting the results. Another situation arises when the data conversion program supplied with the survey system does not have an option to change the data discretization interval and records the positions as measured by the GPS system. You can set the electrode position discretization interval by changing the unit electrode spacing value in line 2 of the data file (eg. from 1.0 to 2.5). Before reading in the data file, select the 'File – Round up positions of electrodes' option where the following dialog box will be shown.

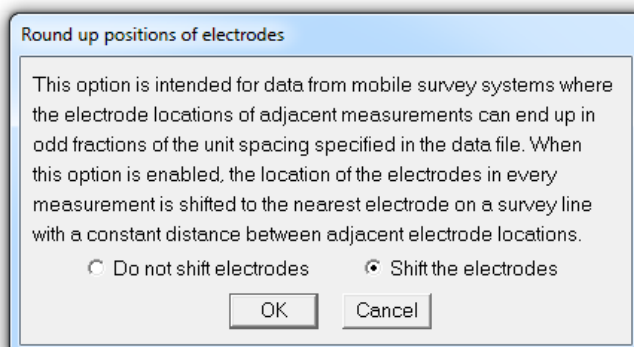

Select the 'Shift the electrodes' option, and then read in the data file. The program will automatically adjust the positions of the electrodes so that the distance of each electrode from the first electrode position is an integer multiple of the unit electrode spacing. In the process of shifting the positions of the electrodes, some measurements might end up having the same electrode positions. When this occurs, the program will display the following dialog box.

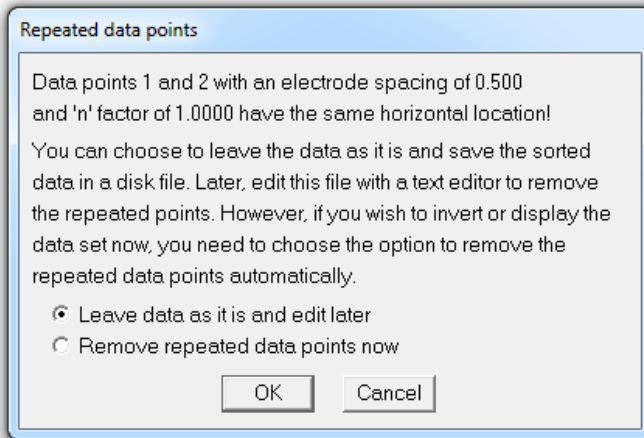

If the 'Remove repeated data points now' option is selected, the program will combine readings with the same electrode positions into a single data point.

8.3 Automatically switch electrodes

Clicking this option will bring up the following dialog box. This option has two functions.

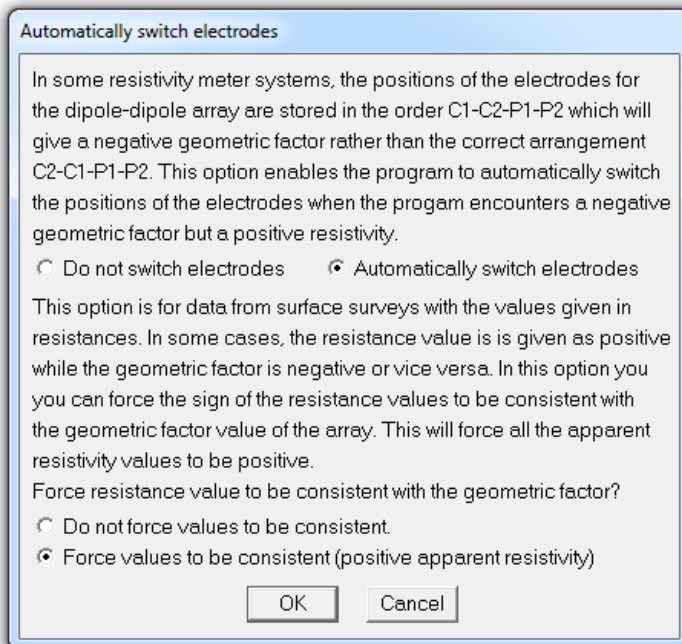

Firstly, it allows the user to automatically switch the positions of the C1 and C2 electrodes for dipole-dipole array data given in the general array format (section 7.2). The positions of the electrodes are frequently listed in the C2-C1-P2-P1 order although this will result in a negative geometric factor. Selecting the 'Automatically switch electrodes' option will swap the positions of the C1 and C2 electrodes so that the array configurations will have a positive geometric factor.

The second option deals with data in the general array format where the measurements are given as resistance values. One common mistake of measurements in resistance values is that the sign of the measurement is sometimes not recorded, i.e. it is always listed as positive. This will result in the sign of the resistance value being inconsistent with the arrangement of the electrodes for cases with a negative geometric factor. If the option to force the apparent resistivity to be positive is chosen, the program will change the sign of the measurements so that when multiplied with the geometric factor a positive apparent resistivity values is always obtained.

8.4 Cut-off factor to remove data

This option is used to filter data with very high geometric factors (and consequently low potentials) that are likely to be noisy. Selecting the menu option will bring up the following dialog box. If the option is enabled, data values below the threshold will be filtered out.

Cutoff value for readings

To avoid possibly very noisy readings, the program will automatically eliminate readings where the potential values are probably very small. The parameter used is the ratio of the smallest to the largest geometric factor. This ratio is usually between 0.0007 to 0.02 (i.e. a ratio of 1400 to 50 times). To change the cutoff value, enter the new value below.

This cutoff value will not be used to eliminate readings if the data is given as resistance values, and the user does not select the option to change the data into apparent resistivity values.

If you wish, you can disable this feature and the program will not filter the input data. In extreme cases this could result in negative calculated apparent resistivity values. If this happens, you can enable this feature or use the apparent resistivity or resistance values directly in the inversion instead of the logarithm of the apparent resistivity.

Do you want to filter the input data? Yes No

8.5 Calculate errors from repeated readings

Clicking this option will bring up the following dialog box. This option calculates an estimated of the data error using repeated or reciprocal measurements.

Estimate error from repeated readings

For data sets with a large number of repeated or reciprocal readings, you can use the difference between the values as an estimate of the data error. Do you calculate the data error automatically?

Yes - calculate error No - do not calculate

8.6 Data Import

Clicking this option will show the following list of sub-options. Use this option to read in the raw data file from different instruments and convert the data into the format used by RES2DINVx64.

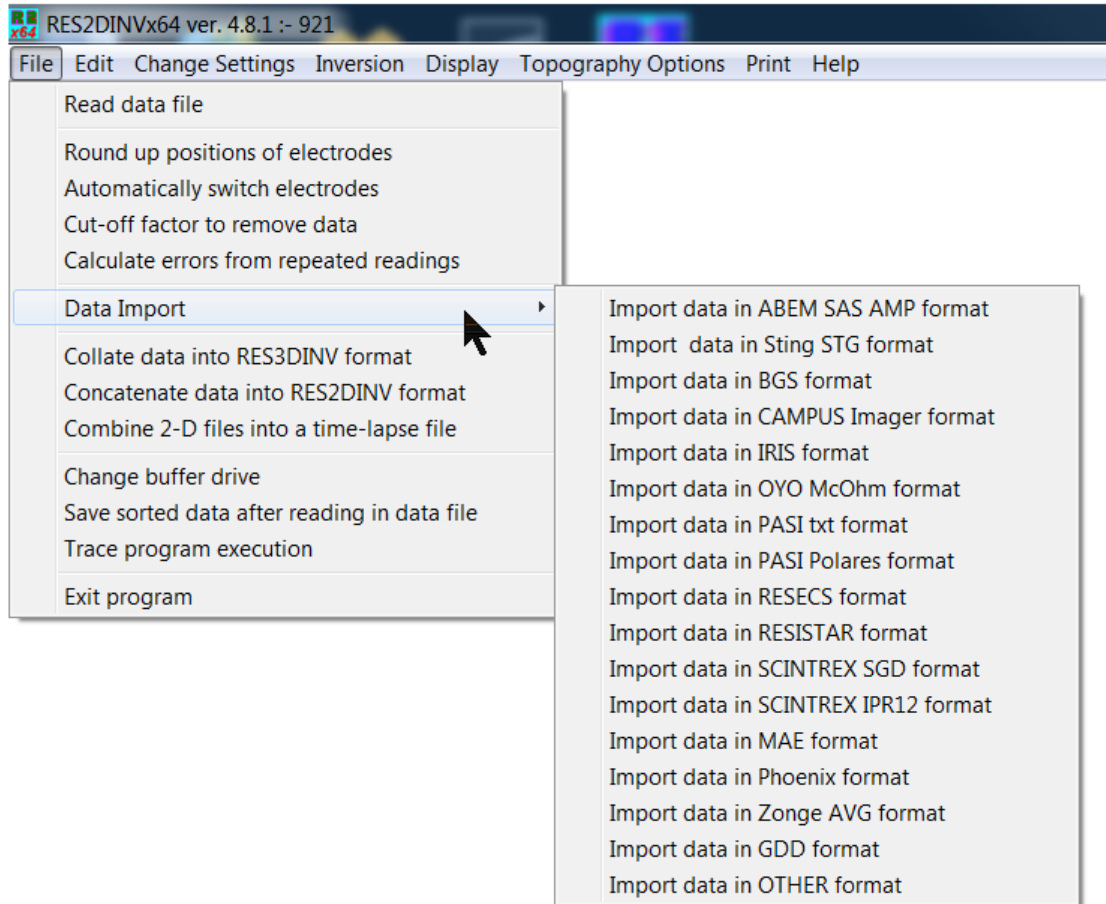

8.7 Collate data into RES3DINV format

(a) Parallel and orthogonal 2-D lines

Ideally, a 3-D survey should be carried out using a rectangular grid of electrodes with measurements in different directions (Loke and Barker 1996). However, for practical reasons, most commercial 3-D surveys use a number of parallel 2-D survey lines with possibly some tie lines in a perpendicular direction. This option enables the user to combine the 2-D lines with data in the RES2DINV format into a single data file in the format used by the RES3DINV program. The file COLLATE_2D_3D.TXT is an example script file used to combine the 2-D files. The contents of this file together with a description of the format used are given in Table 33.

The format used allows for the possibility that the survey has lines in two perpendicular directions. A 2-D survey line has only one horizontal direction, and the coordinate of an electrode along the survey line is given as the distance along the line, starting from the first electrode. To determine the coordinate of the electrode in the X-Y plane for a 3-D survey, we need to determine the coordinate of the first electrode in the 2-D survey line within the X-Y survey grid. This gives a reference point for which the coordinates of the other electrodes along the same survey line can be calculated. Secondly, it is necessary to know the orientation of the line, i.e. whether is along the x -direction or y -direction in the x - y grid. Note that diagonal lines are not allowed.

In a 2-D survey line, it is always assumed that the coordinate of the electrode always increases starting from the first electrode (i.e. from left to right in a typical pseudosection). However, the direction of increasing coordinate value along the 2-D survey line might not always be the same as the positive x or y direction in the 3-D survey x - y grid. The 'Line sign' parameter allows for the possibility that the direction of the 2-D survey line is opposite to the direction of the positive x or y axis in the x - y grid.

Table 33. Example script file to combine 2-D data files into a 3-D data file.

<i>COLLATE_2D_3D.TXT file</i>	<i>Comments</i>
Conversion of RES2DINV data files	<i>Title</i>
Number of files to collate	<i>Header for no. of data files</i>
3	<i>Number of data files</i>
File 1 parameters	<i>Header for first file</i>
Name of data file in RES2DINV format	<i>Header for name of file</i>
d:\test\FILE2D_1.DAT	<i>Full name plus path of file</i>
X and Y location of first electrode along this line	<i>Header</i>
0.0,0.0	<i>Coordinates of the first electrode</i>
Line direction (0=X,1=Y)	<i>Header</i>
0	<i>Number specifying line direction</i>
Line sign (0=positive,1=negative)	<i>Header</i>
0	<i>Specify whether electrode coordinates increase or decrease along line</i>
File 2 parameters	<i>Same set of parameters for second file</i>
Name of data file in RES2DINV format	
d:\test\FILE2D_2.DAT	
X and Y location of first electrode along this line	
0.0,-0.5	
Line direction (0=X,1=Y)	
0	
Line sign (0=positive,1=negative)	
0	
..	
..	<i>Similar information for third file</i>
..	
Name of output file in RES3DINV format	<i>Header</i>
d:\test\FILE_3D.dat	<i>Name of 3-D data file</i>
End of file	<i>Header for end of file</i>

While it is possible to combine a number of 2-D lines into a 3-D data set, it might not always be worthwhile to do so. Firstly, it is recommended that there should be at least 5 parallel lines. The separation between the lines should not be more than twice the unit electrode spacing along the lines. For further details, please refer to Chapter 8 of the free “Tutorial : 2-D and 3-D electrical imaging surveys” (Loke 2018). It can be downloaded from the www.geotomosoft.com web site. The RES3DINVx64 program will carry a true 3-D inversion (in that the resistivity values are allowed to vary in all 3 directions simultaneously during the inversion process). A discussion on the inversion of such 3-D data sets is found in Loke and Dahlin (2010).

(b) 2-D lines in arbitrary directions

The previous example assumes the 2-D lines are parallel or orthogonal so that the electrodes used fall in a simple rectangular grid. In some surveys, particularly over rugged terrain, this might not be possible. The RES3DINVx64 program supports an ‘arbitrary electrodes’ data format whether the electrodes can be arranged in practically any pattern. In order to convert the ‘local’ coordinates used for each 2-D survey lines into a common ‘global’ coordinate system used for the 3-D data file, each 2-D data file must contain the ‘Global or GPS’ coordinates as described in section 7.11. The information in the ‘Global or GPS’ coordinates in the 2-D files are then used to position the electrodes in the 2-D survey lines in the common 3-D coordinate system. An example of the format used is given in the COLLATE_2D_TO_3D-Arbitrary.TXT script file. The contents of this file are listed in Table 34 with a description of the information lines.

Table 34. Example script file to combine data from 2-D lines in different directions into a 3-D data file.

<i>COLLATE_2D_TO_3D-Arbitrary.TXT file</i>	<i>Comments</i>
Conversion into 3-D arbitrary electrodes data format	<i>Title</i>
Number of files to collate	<i>Header for no. of data files</i>
17	<i>Number of data files</i>
Arbitrary point electrodes format	<i>Header to indicate 3-D arbitrary electrodes format used</i>
X model grid spacing	<i>Spacing in x-direction for model grid</i>
1.0	<i>X spacing value</i>
Y model grid spacing	<i>Spacing in y-direction for model grid</i>
1.0	<i>Y spacing value</i>
File 1 parameters	<i>Header for first file</i>
Name of data file in RES2DINV format	<i>Header for name of file</i>
c:\test\block32x19b-x-00.DAT	<i>Full name plus path of file</i>
File 2 parameters	<i>Same set of parameters for second file</i>
Name of data file in RES2DINV format	
c:\test\block32x19b-x-02.DAT	
...	
...	<i>Similar information for other files</i>
...	
Name of output file in RES3DINV format	<i>Header</i>
c:\test\block32x19b-3D.dat	<i>Name of 3-D data file</i>
End of file	<i>Header for end of file</i>

For each 2-D line, only the name of the data file is needed. Unlike the format used in Table 33 for parallel or orthogonal lines, the orientations or positions of the lines are not needed. This is because it is assumed this information is contained in the ‘Global or GPS’ coordinates sections of the 2-D file. Another important difference is that the model grid spacings in the x and y directions must be specified by the user. It is recommended that you use values that are similar to the electrode spacings used in the 2-D lines. You can use different model grid spacings in the x and y directions, for example some surveys use spacings between the lines in the y direction that are 2 or more times the in-line electrode spacings in the x direction. However, it is recommended that the grid spacings should not differ by more than a factor of 2 times. The model grid automatically generated by this option might not be optimal, for example some parts of the grid might only be sparsely covered by the survey lines. If necessary, you can edit the 3-D data file generated manually using a text editor to optimize the grid spacings and number of grid lines. Please refer to section 7.2.3 of the RES3DINVx64 manual for details on the data format, and section 8.9.2 of ‘Tutorial : 2-D and 3-D electrical imaging surveys’ (Loke 2018) on methods to optimize the model grid.

The equatorial dipole-dipole and offset pole-dipole arrays have offline electrodes. To fix the positions of the offline electrodes, a modification to the ‘Global or GPS’ coordinates data format is needed as shown in Table 35.

There are two main differences. Firstly, an extra data line ‘Second line of Global coordinates present’ must be included to indicate the change in the format. Secondly, for each local coordinate point there are two pairs of the (x,y,z) global coordinates, one for the main survey line and another for the offset line. As an example, for the offset pole-dipole array the C1 electrode will be located along the main survey line while the P1 and P2 electrodes are assumed to be on the offset line. Note that elevation value for the global coordinate must also be given to allow for cases where the elevation along the offset line is different from the main survey line.

Table 35. Example data file with global coordinates for an array with offline electrodes.

<i>Data file</i>	<i>Comments</i>
..	<i>Initial part with main data section with</i>
..	<i>data points and topography</i>
Global Coordinates present	<i>Header to indicate GPS information present</i>
Second line of Global coordinates present	<i>Extra header to indicate coordinates for offline electrodes present</i>
Number of coordinate points	<i>Header</i>
3	<i>Number of coordinate points</i>
Local Long. Lat. Elev Long. Lat. Elev	<i>Header</i>
10.0 100.0 300.0 20.0 101.0 304.0 21.0	<i>Local position along line, GPS Longitude, GPS Latitude</i>
20.0 158.1 327.8 22.0 157.1 331.5 22.5	<i>Second coordinate point</i>
96.0 223.3 365.4 18.0 222.3 369.4 19.0	<i>Third coordinate point</i>
0	<i>Zeros to indicate other options,</i>
0	<i>such as fixed regions etc.</i>
0	<i>not present</i>

8.8 Concatenate data into RES2DINV format

This option enables the user to combine roll-along data files measured along the same line into a single data file. All of the electrodes used in the survey lines are along a single straight line. The file `CONCATENATE_2D.TXT` an example script file. The contents of this file together with a description of the format used are given in Table 36. In some resistivity multi-electrode systems, each new record starts with a zero location for the first data electrodes. In order to combine different data files, the x -locations of the data points in some of the files will have to be shifted so that all of them have a common origin. In the above script file format, this is done by entering the coordinate of the first electrode for the survey line. In most cases, the directions of the lines are the same, for example the x -locations increase from the left to the right. However, an option is provided where the survey lines were measured in different directions.

Table 36. Example script file to concatenate 2-D data files.

<i>CONCATENATE_2D.TXT file</i>	<i>Comments</i>
Concatenation of several data files in RES2DINV	<i>Title</i>
Number of files to concatenate	<i>Header for no. of data files</i>
3	<i>Number of data files</i>
File 1 parameters	<i>Header for first file</i>
Name of data file in RES2DINV format	<i>Header for name of file</i>
c:\data\file1.DAT	<i>Full name plus path of file</i>
X location of first electrode along this line	<i>Header</i>
0.0	<i>Coordinates of the first electrode</i>
Line sign (0=positive,1=negative)	<i>Header</i>
0	<i>Specify whether electrode coordinates increase or decrease along line</i>
File 2 parameters	<i>Same set of parameters for second file</i>
Name of data file in RES2DINV format	
c:\data\file2.DAT	
..	
..	<i>Similar information for 2nd and 3rd files</i>
..	
Name of output file in RES2DINV format	
c:\data\file_123.DAT	<i>Name of file to store combined data</i>
End of file	<i>Header for end of file</i>

8.9 Combine 2-D files into a time-lapse file

This option is to combine separate 2-D data files, measured at different times using the same line setup, into a single time-lapse data file (section 7.6). An example script files to implement this is the Time-2d-collate.txt file. The contents of this file together with a description of the format used are given in Table 37. The format is similar to that used to collate or concatenate files where a list of input the data files and an output file is listed. In this case, the name of each file and the time it was measured is required.

Table 37. Example script file to combine 2-D data files into a time-lapse file.

<i>Time-2d-collate.txt file</i>	<i>Comments</i>
Block model 3 files	<i>Title</i>
Time unit	<i>Unit used for time</i>
Day	<i>Day in this case</i>
Number of files	<i>Header for no. of data files</i>
3	<i>Number of data files</i>
File 1	<i>Header for first file</i>
c:\test\m01.dat	<i>Full name plus path of file</i>
Time measured	<i>Header</i>
0	<i>Time measured</i>
File 2	<i>Header</i>
c:\test\m02.dat	<i>Full name plus path of second file</i>
Time measured	<i>Same set of parameters for second file</i>
1	<i>Time second data set measured</i>
File 3	<i>Similar information for third file</i>
c:\test\m03.dat	
Time measured	
1	
Output file name	<i>Header</i>
c:\test\mtime3.dat	<i>Name of file to store time-lapse data</i>
End of file	<i>Header for end of file</i>

8.10 Change buffer drive

The program will automatically select the hard-disk drive with the largest amount of free space as the buffer drive to store temporary files used in the inversion routine. This option allows the user to change the buffer drive, such as to a faster SSD drive.

8.11 Save sorted data after reading in data file

Selecting this option will bring up the following dialog box.

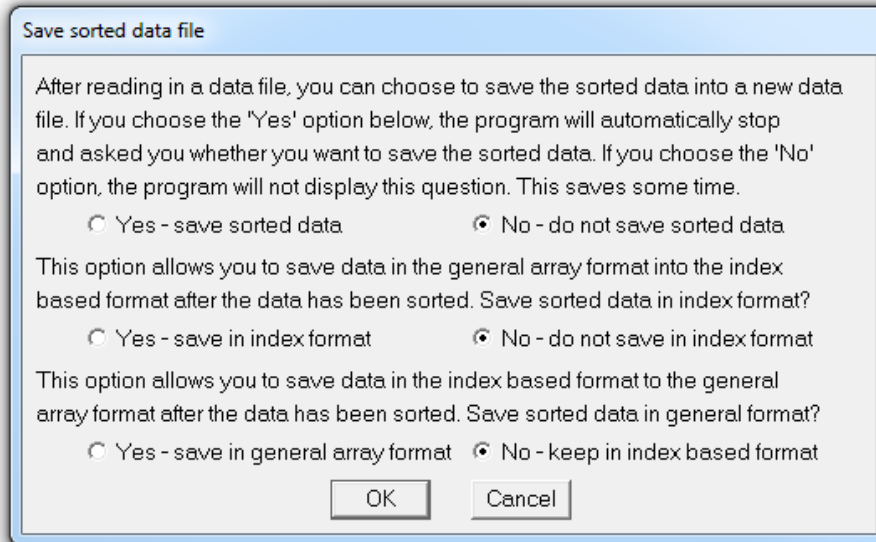

When the program reads in a data file, it will sort the data according to depth of investigation of the array. For index based data, it will group the data points according to the '*a*' and '*n*' values used. If the first option is selected, the program will save the data after sorting into a separate data file. If the original data file is in a general array format, but a standard array was used, the second option allows the user to save the data in a file using the index based format. This makes it easier to detect problems with the data, such as the use of large '*n*' values with the Wenner-Schlumberger, pole-dipole and dipole-dipole arrays. The third option converts data originally in the index based format to the general array format. This is useful as certain options, such as extending the model range (section 7.12), is only available for data in the general array format.

8.12 Trace program execution

When this option is enabled, the program will dump information into a R2DTRACEX64.TXT file during the inversion process. This is mainly used to trace problems in the program if it is unable to read or invert a data file. The file will be saved in the 'temp_buffer_2di' folder in the buffer drive.

9 Edit menu options

This section covers a few data editing options to remove bad data points, trim very long profiles, reverse the direction of a data set and to change the location of the beginning of the line. Clicking this option will show the following list of sub-options.

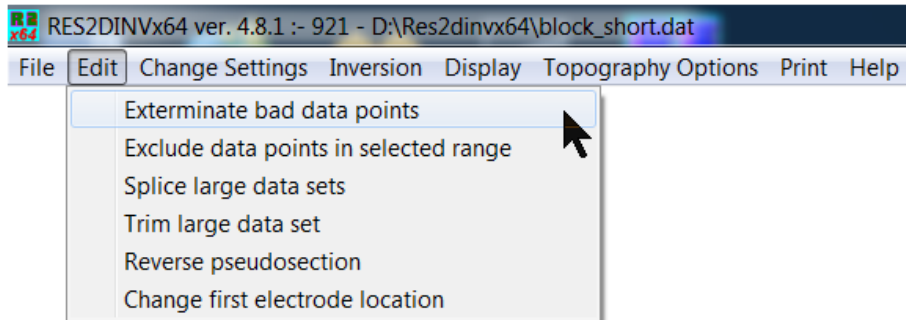

9.1 Exterminate bad data points

In this option, the apparent resistivity data values are displayed in the form of profiles for each data level. This can only be used for data collected using conventional arrays. You can use the mouse to remove any bad data point. The main purpose of this option is to remove data points that have resistivity values that are clearly wrong. Such bad data points could be due to the failure of the relays at one of the electrodes, poor electrode ground contact due to dry soil, or shorting across the cables due to very wet ground conditions. These bad data points usually have apparent resistivity values that are obviously too large or too small compared to the neighboring data points. The best way to handle such bad points is to drop them so that they do not influence the model obtained. Figure 20 shows an example of a data set with a few bad points. To remove a bad data point, move the cross-shaped cursor with the mouse to the data point and click the left mouse button. The color of the data point should change from black to purple. If you click the same data point again, it will not be removed from the data set. Besides removing a single data point, there are other functions that removes a series of data points. Clicking 'Help' in the menu bar will display the list of keys or mouse clicks that can be used.

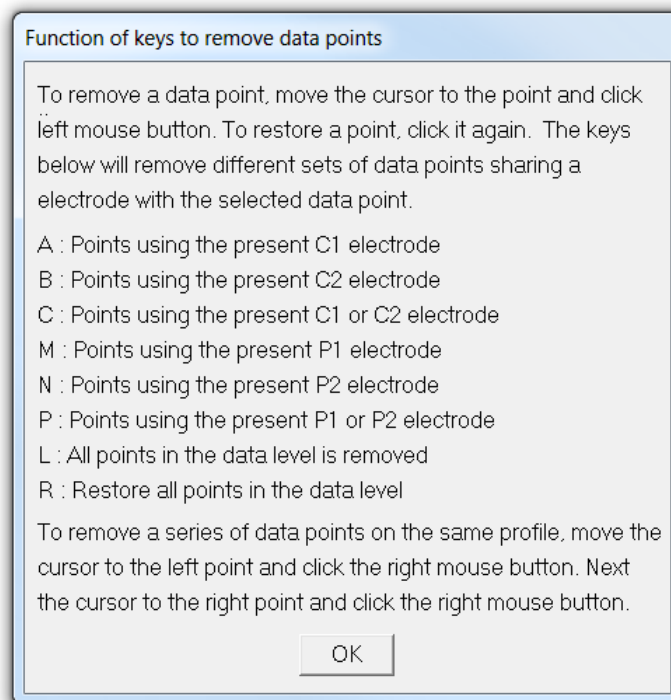

For example, you can remove a series of data points on the same profile using the right mouse button. If the contact at one of the electrodes is bad, you can remove all the data points associated with that electrode. To quit from this option, just press the **Q** key or click the Exit option. You will then be prompted to save the edited data into a new file.

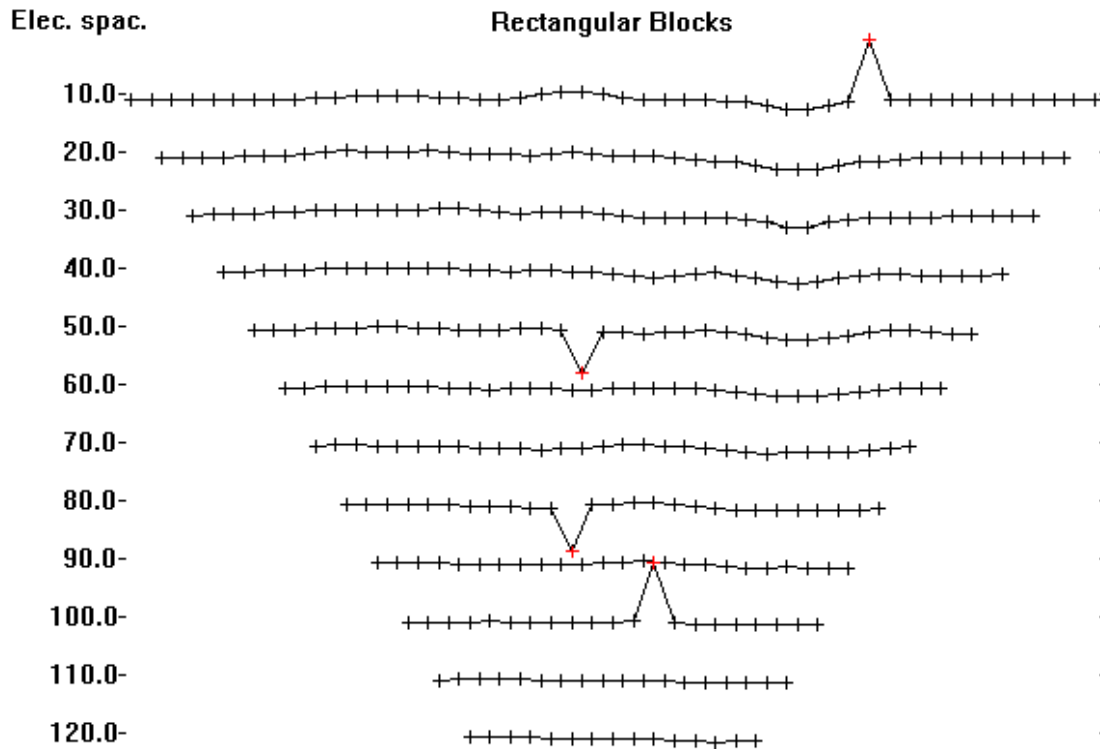

+ Measured data + Removed data

Figure 20. Example of a data set with a few bad data points. The data is displayed using the "Exterminate bad data points" option.

9.2 Splice large data sets

This option enables you to choose a section of the full data set (which is too large to be processed at a single time) to invert. For data given in the index based format (section 7.1), the distribution of the data points in a pseudosection will be displayed such as in Figure 21. You can select a section of the data set to invert by using the arrow keys. Instructions on the keys to use are displayed on the screen. You can also display the list of editing keys used by selecting the 'Help' menu option that will display the following information box.

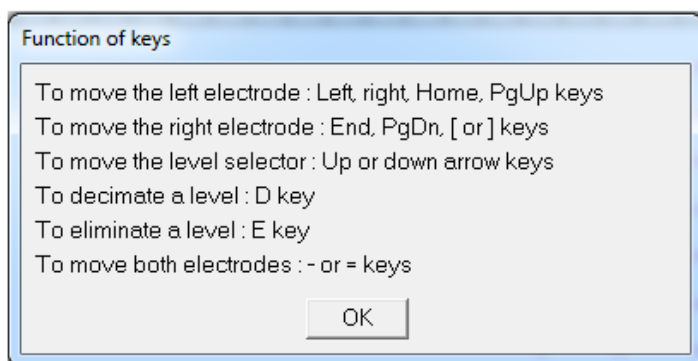

The data points selected will be marked by purple crosses or dots, whereas the remaining data points are black. At the top of the display, the left and right limits of the section selected are marked by yellow vertical lines. If there are too many data points in the lower levels, you can reduce the number of data points by selecting only odd or even points in a level. To do this, move the horizontal yellow marker on the left side of the display up or down to the level you want to decimate using the up and down arrow keys. Then press D to decimate the data points in that level. Using this option, you can select a section of the data set to invert. The entire data set can then be inverted by inverting successive subsections of the data set. After selecting the data set sub-section you want invert, will need to save it to a new file.

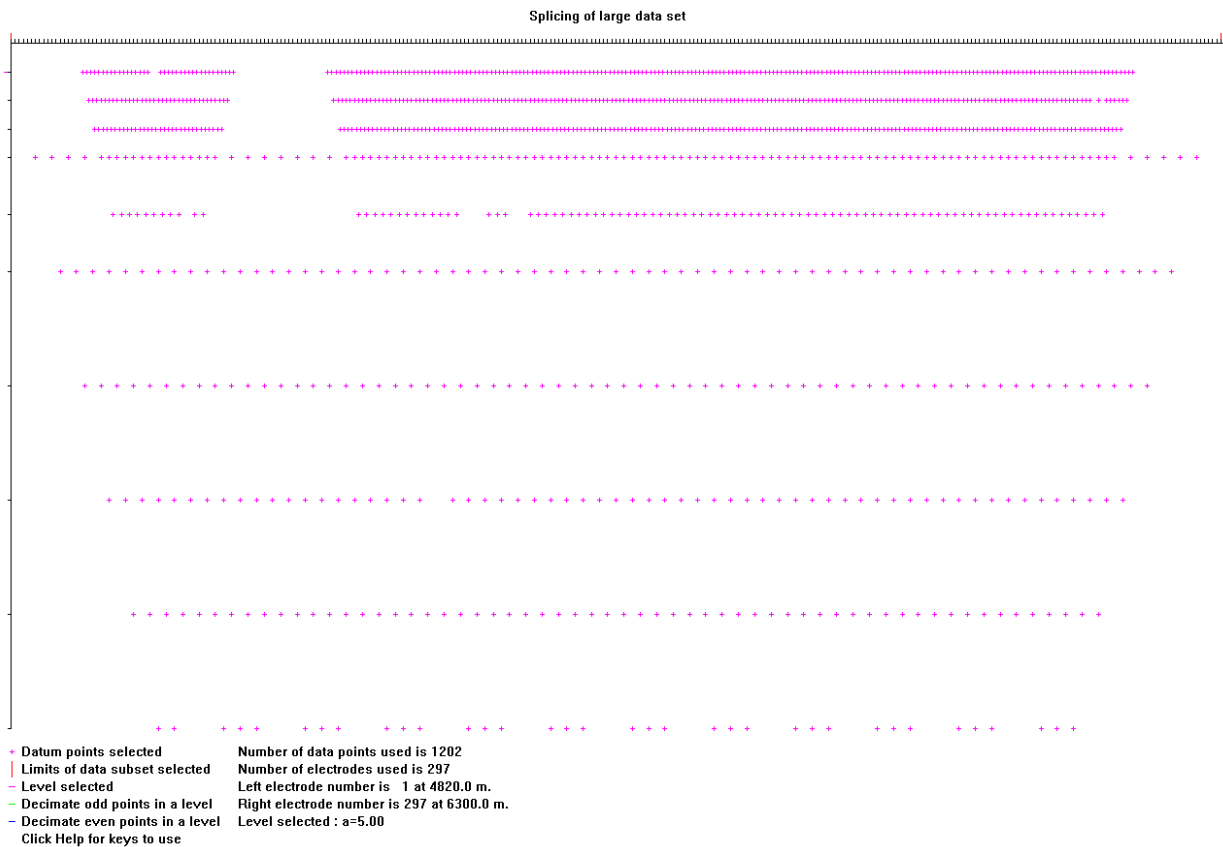

Figure 21. Example of a display using the splice data option for a data set in the indexed base format.

For data is given in the general array format, you can trim the data by changing the left and right limits of the data set, as in the following dialog box. You can also remove data near the top or bottom of the pseudosection by setting limits on the depth values.

Trim data set

The minimum and maximum electrode positions are 0.00 and 490.00.
 Please enter the minimum and maximum electrode locations for the trimmed data set below.

Minimum location selected : Maximum location selected :

The pseudodepths of the data points range from 4.16 to 103.80.
 Please enter the minimum and maximum pseudodepths for the trimmed data set below.

Minimum pseudodepth chosen : Maximum pseudodepth chosen :

Number of data points selected is 469 out of 469.

In general, it is recommended that you try to invert the entire data set at a single time. The inversion of long survey lines is no longer a problem with RES2DINVx64. If the data is from a long survey line with more than 500 electrode position, you can select the "Sparse inversion" option to significantly reduce the calculation time and computer memory required (see section 11.2.6).

9.3 Trim large data set

This option is similar to the previous option, except the dialog box to set the left and right limits (and upper and lower limits for the pseudodepths) of the data set is always shown, even for data given in the index based format.

9.4 Reverse pseudosection

This option flips the pseudosection horizontally from left to right. This is helpful when you have parallel survey lines but the surveys were started from different ends.

9.5 Change location of first electrode

This allows you to change the location of the first electrode in the survey line. It is basically intended for plotting purposes, so that overlapping survey lines have the same x -locations for electrodes that coincide.

10 Change Settings menu options

This menu contains a number of options that control the parameters used in the inversion of the data set. This option shows the following menu.

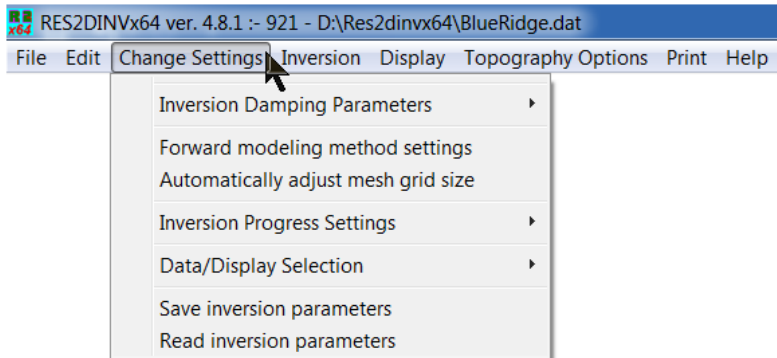

10.1 Inversion Damping Parameters

This covers a list of options that control the damping factor, λ in equation (4.1), used in the smoothness-constrained least-squares inversion equations. The following list of sub-menu options is displayed when this option is selected.

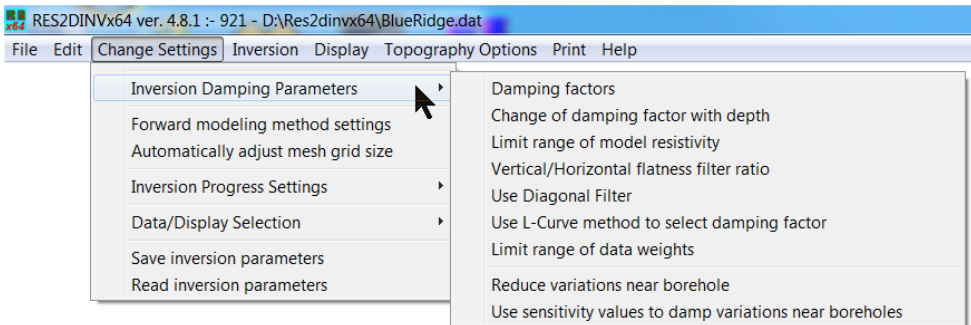

10.1.1 Damping factors

Selecting this option will bring up the following dialog box.

Set Damping Factors

Initial Damping Factor
The initial damping factor should normally has a value of between 0.25 and 0.05. You should use a correspondingly larger damping factor for a noiser data set. If you are not sure, use a value of about 0.15.
Initial damping factor value selected :-

Minimum Damping Factor
The minimum damping factor should normally has a value of between 0.01 and 0.10. You should use a correspondingly larger damping factor for a noiser data set. If you are not sure, use a value of about 0.03.
Minimum damping factor value selected :-

First Layer Damping Factor
For some data sets with very sparse data points, the first layer can show a rippling pattern. To reduce this artifact, you can use a higher damping factor for the first layer.
Use higher damping for first layer? :- Yes No
Higher damping factor value for first layer (1 to 20) :-

Apply higher damping factors for blocks at sides of model to reduce edge effects?
 No - Do not use higher damping factors Yes - Use higher damping factors.

Adjust damping factors for changes in distances between the blocks in the model?
 No - Use uniform damping factors. Yes - Adjust damping factors.

You can set the initial value for the damping factor λ in equation (4.1), as well as the minimum damping factor. The inversion program automatically reduces the damping factor by about half after each iteration until it reaches the selected minimum value. If the data set is very noisy, you should use a relatively larger damping factor (for example 0.3). If the data set is less noisy, use a smaller initial damping factor (for example 0.1). The inversion subroutine will generally reduce the damping factor but

a minimum limit for the damping factor must be set to stabilize the inversion process. The minimum value should usually set to about one-tenth to one-fifth the initial damping factor value. For some data sets, particularly when the 'Model refinement' option is used to select a model with narrower blocks (section 11.3.8), the first few layers can show a rippling effect. This can be reduced by using a higher damping factor for the first layer. There is usually less data near the ends of the survey line, so an option to use higher damping factor for the model cells at the sides of the model is used. The last option allows the user to adjust the damping factor for the different layers to take into account changes in the distances between the model cells.

10.1.2 Change of damping factor with depth

Since the resolution of the resistivity method decreases exponentially with depth, the damping factor used in the inversion least-squares method is normally also increased with each deeper layer in order to stabilize the inversion process. Normally, the damping factor is increased by 1.05 times with each deeper layer, but you can change it. Use a larger value if the model shows unnatural oscillations in the resistivity values in the lower sections. This will help to suppress the oscillations. You can also select the choice to allow the program to determine the value to increase the damping factor with depth automatically. This might be a good choice if the thickness of the layers is much thinner than the default values, for example if you had reduced the unit electrode spacing by half in the data file in order to produce a model with smaller model blocks.

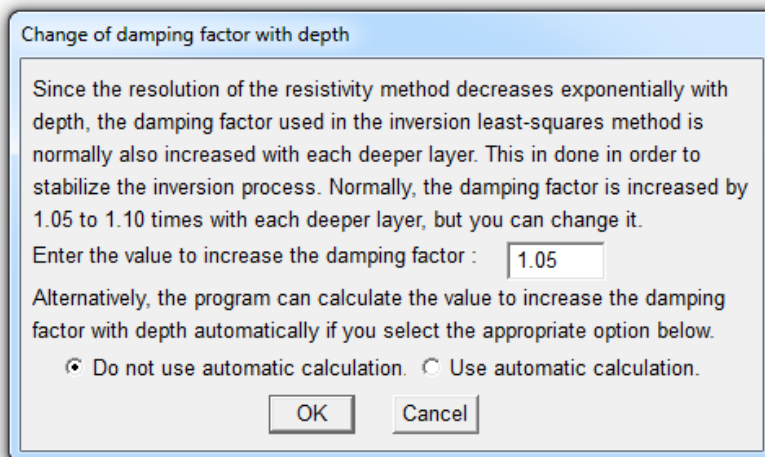

10.1.3 Limit range of model resistivity

When you select this option, the following dialog box will be shown.

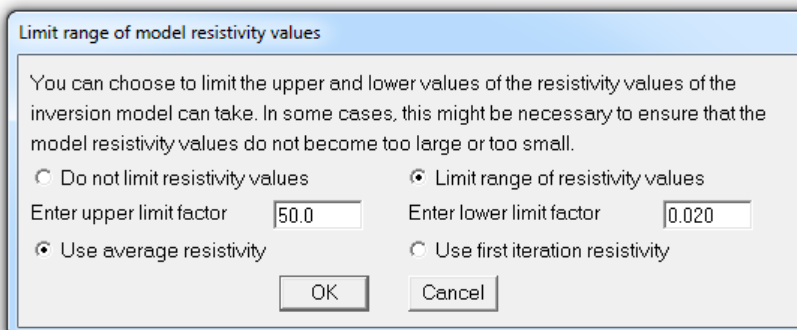

This option allows you to limit the range of resistivity values that the inversion subroutine will give. In the above example, the upper limit for is 20 times the average model resistivity value for the previous iteration while the lower limit is 0.05 times (i.e. 1/20 times). The program uses “soft” limits that allow the actual resistivity model values to exceed the limits to a certain degree. However, this option will avoid extremely small or large model resistivity values that are physically unrealistic. The user can also choose to use the inversion model obtained at the first iteration as the reference model instead of the average apparent resistivity value.

10.1.4 Vertical to horizontal flatness filter ratio

You can select the ratio of the damping factor for the vertical flatness filter (f_z) to the horizontal flatness filter (f_x). By default, the same damping factor is used for both. However, if the anomalies in the pseudosection are elongated vertically, you can force the program to produce models that are also elongated vertically by selecting a higher value (for example 2.0) for the ratio of the vertical to horizontal flatness filter. For anomalies that are elongated horizontally, choose a smaller value (e.g. 0.5).

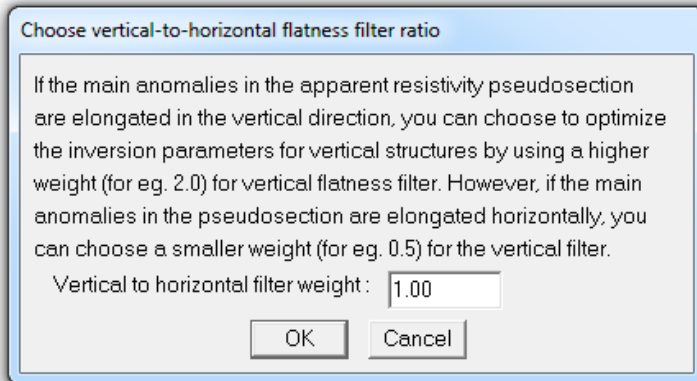

10.1.5 Use diagonal filter

The normal roughness filter used has components in the x and z directions only (Figure 22a). Thus, it has a tendency to produce structures aligned along the x and z directions. To reduce this effect, the roughness filter used can be modified so that it has components in the diagonal directions (Farquharson, 2008) as well (Figure 22b).

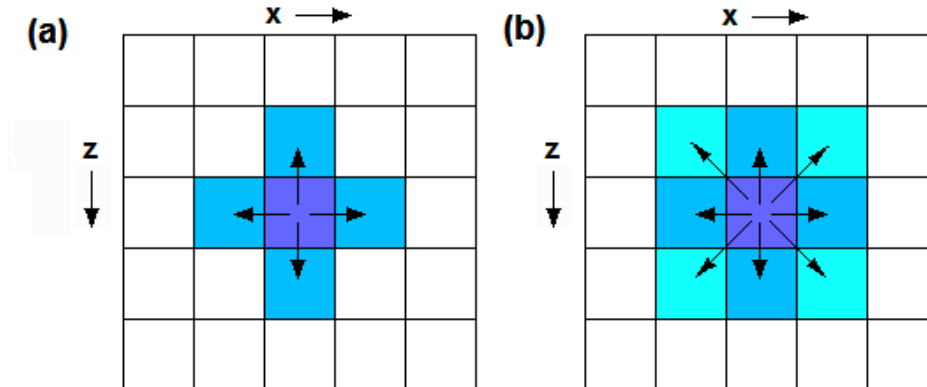

Figure 22. Types of roughness filters. (a) Horizontal and vertical components only. (b) Diagonal components as well.

10.1.6 Use L-curve method to select damping factor

In this option, the optimum damping factor is automatically determined by the program using the L-curve method (Farquharson and Oldenburg 2004). This method essentially estimates the data misfit and the model roughness for a large range of the damping factor values. On selecting this option, the following dialog box is shown.

Use L curve method

You can select the L curve method to estimate the optimum damping factor for the inversion model.

Use the L curve method? :- No, do not use L curve Yes, use L curve method

If you use the L1 norm for the model roughness or data misfit, you can use the the same norm for the L curve method, or always use the L2 norm method within the L curve algorithm.

Use the same norm? :- No, always use L2 norm Yes, use same norm

If you choose to use the L curve method, it is recommended that you use the model refinement method with model cells of half the unit electrode spacing so that near surface structures with large lateral variations are sufficiently modeled by the model grid used.

Type of model cell width :- Cells with 1 unit spacing width Cells with 0.5 unit spacing width

The L curve method will usually select reasonable damping factor values. However to prevent the inversion from becoming unstable in rare cases where the method does not select a reasonable value, the program will set the upper and lower limits for the damping factor value as shown below. You can adjust the limits by typing in the new values.

Minimum allowed damping factor value :-

Maximum allowed damping factor value :-

Normally, the damping factor selected by the L curve method decreases with each iteration and settles down to near constant values after the first few iterations. This option allows the user to ensure that the damping factor does not increase. If it increases, the damping factor for the previous iteration is used. Select option for damping factor change below.

Damping factor not allowed to increase. Damping factor allowed to increase.

The first option is to select the use of the L-curve method to estimate the optimum damping factor. The second option is only relevant if you use the “Robust” or L1-norm method in setting the model roughness filter and data misfit vector (section 11.2.1). This option allows you to use the same L1-norm method within the L-curve routine or use the standard L2-norm method.

The L-curve method assumes the data misfit and the model roughness changes in a smooth manner with the damping factor so that a unique point of maximum curvature is obtained (Figure 23). In some cases, particularly with very large resistivity contrasts near the surface, the standard model discretization (where the width of the model cell is the same as the unit electrode spacing) can result in small ‘kinks’ in the curve. To reduce the effect of any single model cell on the total model roughness, it is recommended that a finer model discretization with model cells of half the unit electrode spacing (in the third option in the dialog box) is used. The fourth option allows the user to set lower and upper limits on the damping factor. If the damping factor determined by the L-curve method falls outside these limits, the value is trimmed to the lower or upper limit. The fifth option is for rare cases where the damping factor increases after an iteration. This option allows the user to ensure it does not increase.

In the program, the damping factor values tested range from 0.01 to 100 times the trial value. Figure 23a shows the variation of the model roughness with the data misfit for the BLUERIDGE.DAT data set for damping factor values ranging from 0.000295 to 2.95. Figure 23b shows a plot of the curvature of the curve against the damping factor value. The optimum value is selected at the point with the maximum curvature value. The calculations are carried out internally by the program for a range of damping factor values. In this example, the trial value used is 0.0295 while the optimum value calculated is 0.0142.

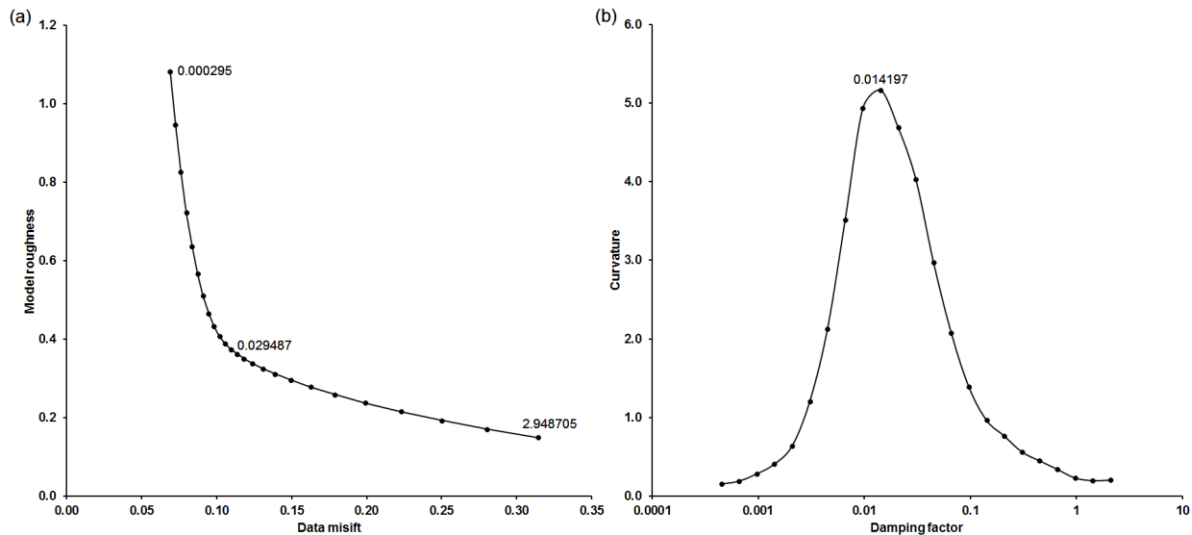

Figure 23. Example L-curve plot to determine the optimum damping factor for the BLUERIDGE.DAT data set. (a) Variation of model roughness with data misfit for a range of spatial damping factor values (a few values are shown near the corresponding points), (b) variation of the curvature of the L-curve with the damping factor.

10.1.7 Reduce variations near boreholes

In some field survey cross-borehole data sets, large resistivity variations are obtained in the inverse model near the borehole electrodes (Ellis and Oldenburg 1995). This option uses higher damping factors for the model cells near the boreholes to reduce such artifacts. Selecting this sub-option will bring up the following dialog box. You can set the degree at which the variations near the borehole are reduced, and also the rate at which the additional damping value is reduced with distance from the boreholes. In this option, the damping factors are set using the distances of the model cells from the boreholes.

Reduce variations near boreholes

For some cases, the model cells that are near to the boreholes can show very large resistivity variations. The following option allows you to reduce these variations. Select 'Yes' to reduce the model resistivity variations near the boreholes.

Yes No

You can set the degree in which the variations near the boreholes are reduced by changing the value below. A larger value will result in smaller variations near the boreholes.

Damping factor to reduce variations :

You can also control the degree the variations near the boreholes are suppressed depending on the distance from the boreholes. A smaller value will result in a greater reduction in the resistivity variations in parts of the model that are further away from the boreholes.

Rate of damping factor reduction :

10.1.8 Use sensitivity values to damp variations near boreholes electrodes

On selecting this option, the following dialog box is shown. In some surveys with subsurface electrodes, prominent artifacts are observed near the subsurface electrodes (Loke *et al.* 2015). This option uses the sensitivity values to set the damping factors. Higher damping factors are used for model cells with higher sensitivity values to suppress the artifacts. This method is more useful in cases where many of the electrodes listed as ‘borehole electrodes’ are actually dummy electrodes that are not actually used. One such situation is when a horizontal line of subsurface electrodes is used (Loke *et al.* 2015).

Reduce variations near electrodes using sensitivity values

To reduce the resistivity variations near the borehole electrodes, you can use the sensitivity values. This is more useful in cases where not all the boreholes electrodes are used, for example when the subsurface electrodes are actually arranged along a horizontal line.

Do you want to use the sensitivity values to set the damping factors?

Yes - use the sensitivity values No - do not use the sensitivity values

You can set the degree in which the variations near the electrodes are reduced by changing the value below. A larger value will result in smaller variations near the electrodes.

Damping factor increase to reduce variations :-

You can also control the degree the variations near the electrodes are suppressed depending on the sensitivity value. A smaller value will result in a greater reduction in the resistivity variations in parts of the model that have higher sensitivity values.

Rate of damping factor reduction with sensitivity :-

Only model cells above a set cutoff sensitivity value will be subject to a higher damping factor.

Cutoff sensitivity values to set higher damping factor :-

10.2 Forward modeling settings

This option sets the parameters used for finite-difference or finite-element forward modeling subroutine used to calculate the apparent resistivity values using the following dialog box.

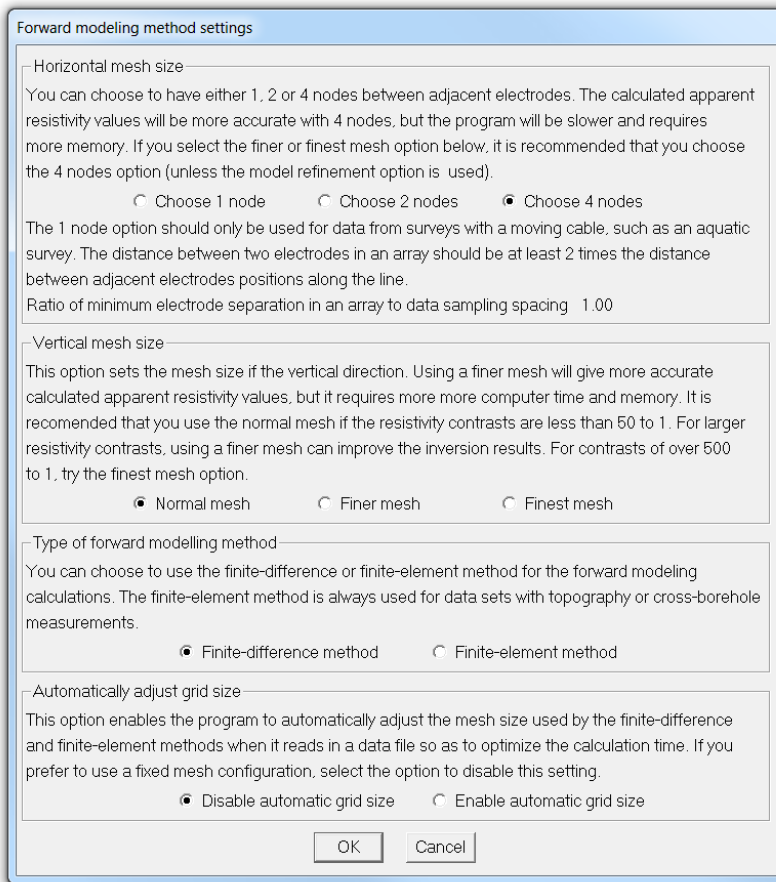

10.2.1 Horizontal mesh size

You can choose a mesh grid used by the forward modeling program to have 2 or 4 nodes between adjacent electrodes (Figure 24). With 4 nodes per electrode spacing, the calculated apparent resistivity values would be more accurate (particularly for large resistivity contrasts). However, the computer time and memory required are correspondingly larger. By default, the program will use the 2 nodes option if the data set involves more than 90 electrode positions. In normal surveys with electrodes planted into the ground, the spacing between adjacent electrodes is usually the same as the minimum spacing between two electrodes used in an array. In surveys using a mobile cable system, such as the OhmMapper on land or a streamer in aquatic surveys, the spacing between adjacent electrodes along the survey line can be several times smaller than the minimum spacing between two electrodes used in an array used for the measurements. For such data sets, the '1 node' option can be used to reduce the calculation time and memory required by the forward modeling routine.

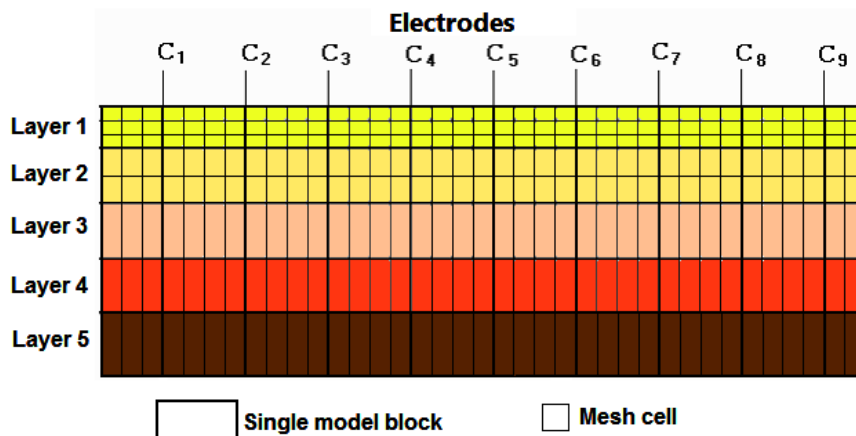

Figure 24. Schematic diagram of mesh and model cells used by forward modeling routine. This example has 4 nodes between adjacent electrodes.

10.2.2 Vertical mesh size

This option allows you to use a finer mesh (in the vertical direction) for the finite-difference or finite-element method (Figure 24). The model for a survey line on the surface normally uses a finer mesh for the top two layers, and a single mesh line for the deeper layers. This option allows the use of a finer mesh for the deeper layers. The apparent resistivity values calculated will be more accurate with a finer mesh, but the computer time and memory required will be greater. The use of a finer mesh can give better results for cases where subsurface resistivity contrasts of greater than 20:1 is expected. This is particularly useful in areas where a low resistivity layer lies below a high resistivity layer.

10.2.3 Type of forward modeling method

This program allows you to use either the finite-difference or finite-element method to calculate the apparent resistivity values. By default, the program will use the finite-difference method which is faster if the data set does not contain topography. If the data set contains topography, the default choice is the finite-element method.

10.2.4 Automatically adjust mesh grid size

This option allows the program to automatically adjust the mesh parameters when it reads in a data file. For example, if it is a survey line with many electrodes, the '2 nodes' between adjacent electrode positions option is automatically selected. However, this option can be disabled to use the same settings for all data sets.

10.3 Inversion progress settings

The following set of options control the path the inversion subroutine takes during the inversion of a data set. The sub-options menu is shown below.

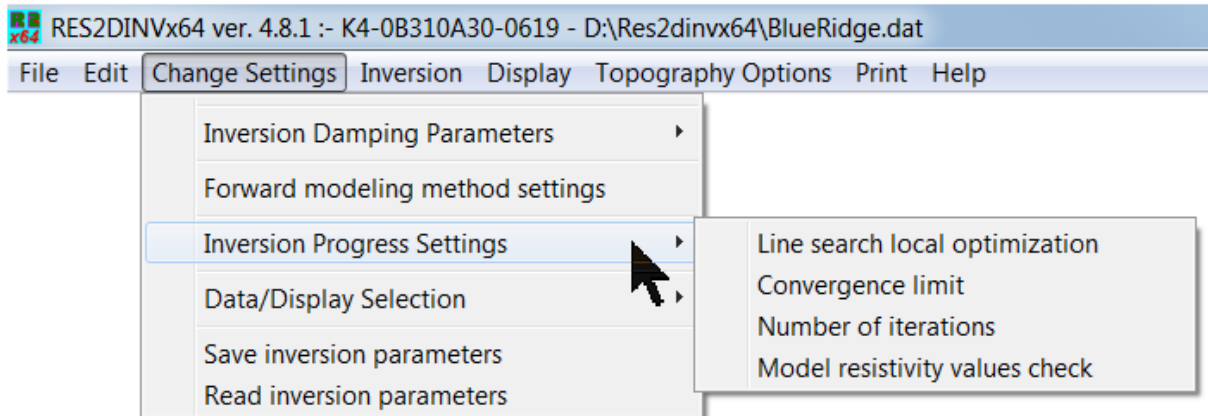

10.3.1 Line search local optimization

The inversion routine determines the change in the model parameters $\Delta\mathbf{q}$ from solving equation (4.1). It attempts to find the optimum amplitude for the parameter change vector $\Delta\mathbf{q}$ using quadratic interpolation if this option is enabled.

10.3.2 Convergence limit

The program has two methods to test for convergence. The first is the relative change in the RMS error between 2 iterations. By default, a value of 5% is used. This is used to accommodate different data sets with different degrees of noise present. The second is the RMS data misfit itself. This sets the percentage RMS error in the inversion of the apparent resistivity data where the program will stop after the model produce has an RMS error less than this limit. Normally a value of between 1% and 5% should be used, depending on the quality of the data.

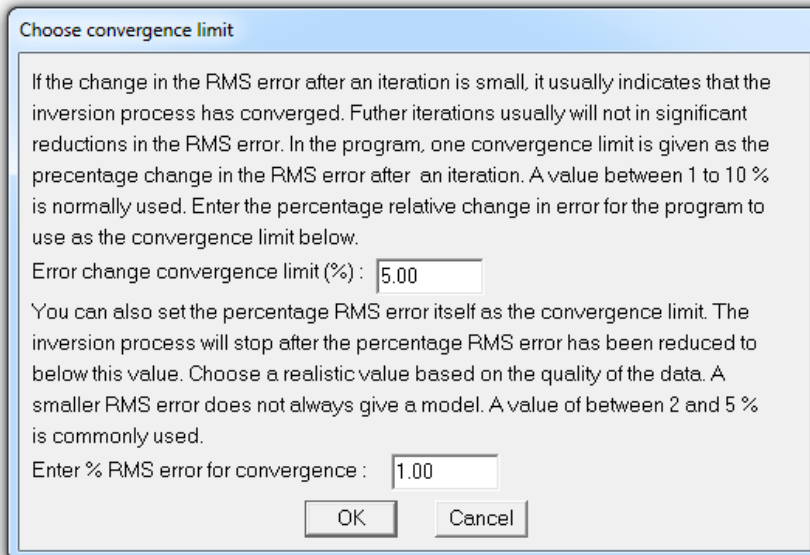

10.3.3 Number of iterations

This allows the user to set the maximum number of iterations for the inversion routine using the following dialog box. By default, the maximum number of iterations is set to 5. For most data sets, this is probably sufficient. When the inversion routine reaches this maximum limit, it will ask the user for the number of additional iterations if you wish to continue with the inversion process. It is usually not necessary to use more than 10 iterations.

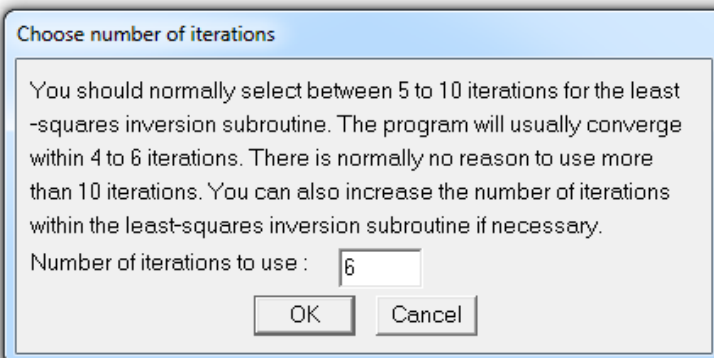

10.3.4 Model resistivity values check

The program will display a warning if after an iteration in the inversion of the data set, a model resistivity value becomes too large (more than 20 times the maximum apparent resistivity value) or too small (less than 1/20 the minimum apparent resistivity value). This option allows you to disable the warning using the dialog box below.

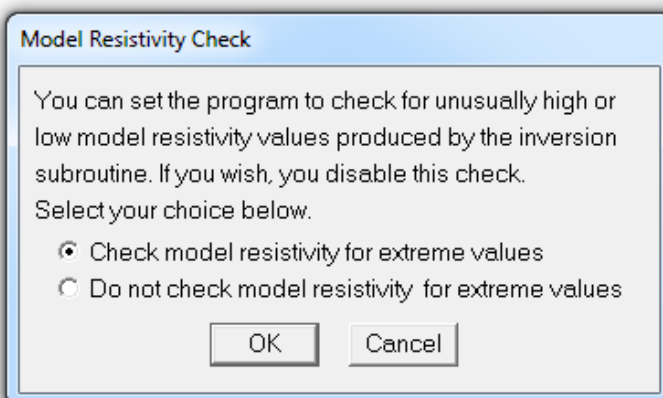

10.4 Data/Display Selection

This section has options for display of the sections during the inversion. The following sub-options will be shown on selecting this option.

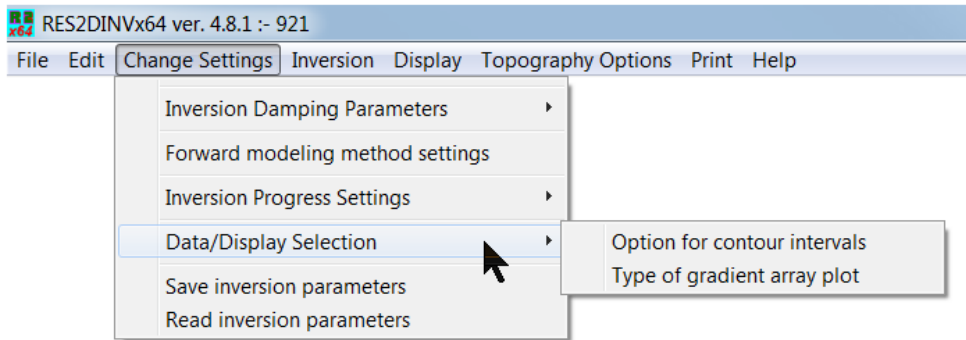

10.4.1 Option for contour intervals

By default, the program will use logarithmic contour intervals for the pseudosections and model sections when displaying the results in the “Inversion” option in the Main Menu. This is usually the best choice for most data sets. However, you can choose to use the linear or the user defined contour intervals options if you wish.

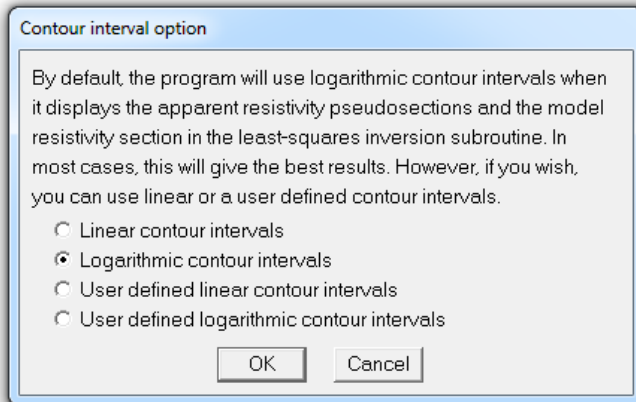

10.4.2 Type of gradient array plot

There is currently no standard method to plot the apparent resistivity data from surveys with gradient array. There are probably two types of surveys with the gradient array. The first and traditional type survey use very few different C1-C2 positions (usually only one with C1 and C2 located at the two ends of the line) but many different P1-P2 positions. This was mainly used in mineral exploration surveys. The second and modern type, mainly used with multi-channel multi-electrode resistivity meter systems, uses many different C1-C2 positions (a multiple gradient array). To accommodate both possibilities, two types of data plotting options are available. As most surveys will likely to be carried out using the second type of survey with multiple C1-C2 positions, this is described in more detail. The papers by Dahlin and Zhou (2004, 2006) have some information about such surveys. On selecting the ‘Type of gradient array’ sub-option, the following dialog box is shown.

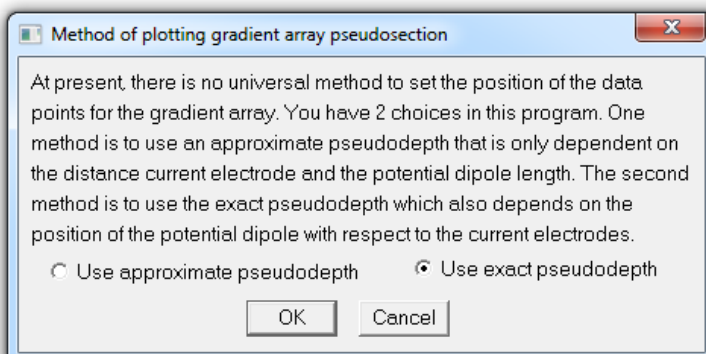

The ‘Use exact pseudodepth’ choice is the default option. However, the program will automatically change to the approximate pseudodepth method if it finds the exact pseudodepth method is not suitable for the data file, such as for surveys with the traditional type of gradient arrays where only a few C1-C2 positions are used. Figure 25 shows a plot of the data from a survey using the multiple gradient array by Aarhus University (for the Danish Road and Highway Association) in the form of profiles. Note that each pseudodepth is split into two profiles shown in different colors. There are two arrangements with the same pseudodepth for non-symmetrical configurations of the gradient array (Figure 26). The distance between the C1 and C2 electrodes are the same, but the offset of the P1-P2 dipole from the C1 electrode in (a) is the same as the dipole offset from the C2 electrode in (b). However, the two configurations are sensitive to different parts of the subsurface (Dahlin and Zhou 2006). To provide a smooth plot for the profile, the data from the ‘right’ and ‘left’ configurations are plotted in different profiles.

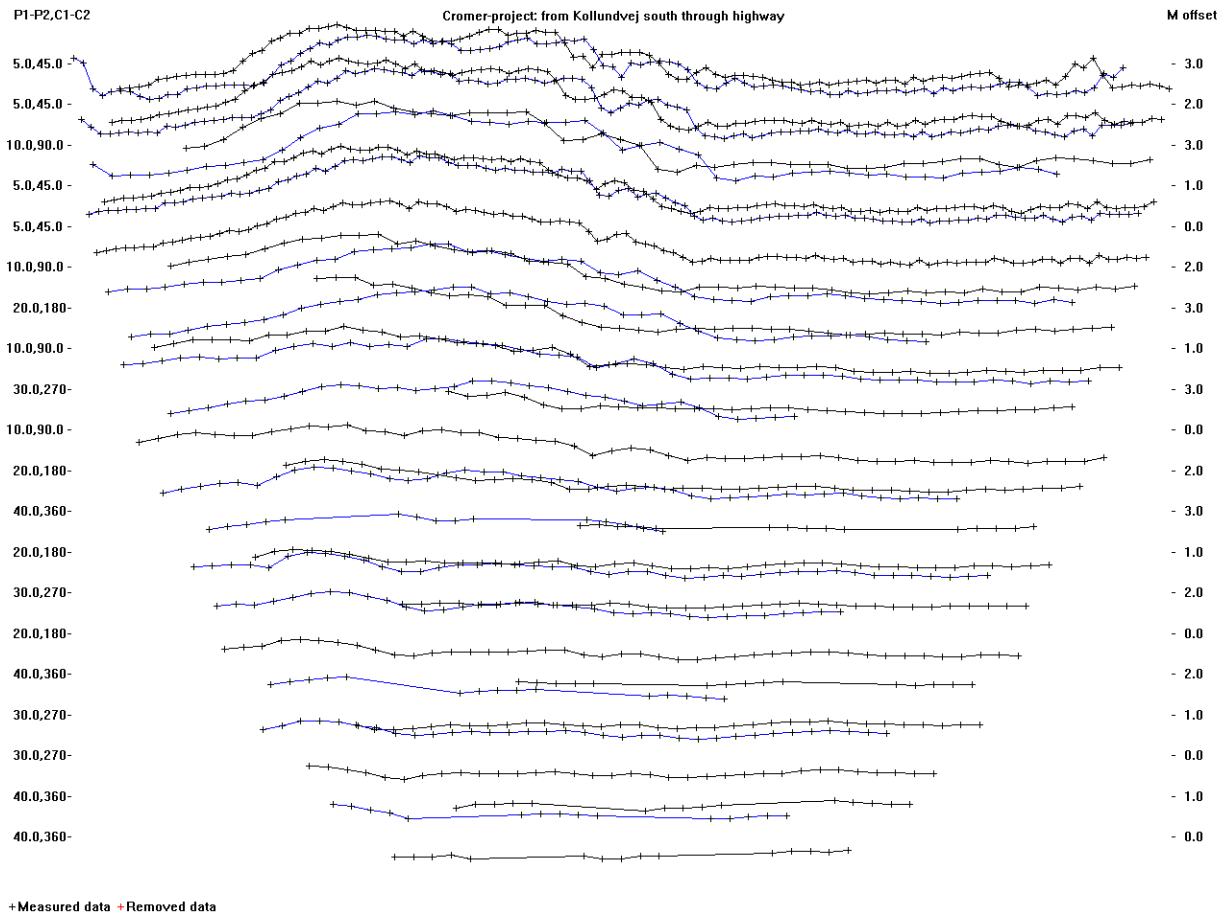

Figure 25. Plot of a multiple gradient array data set in the form of profiles using exact pseudodepths for the CROMER2.DAT file.

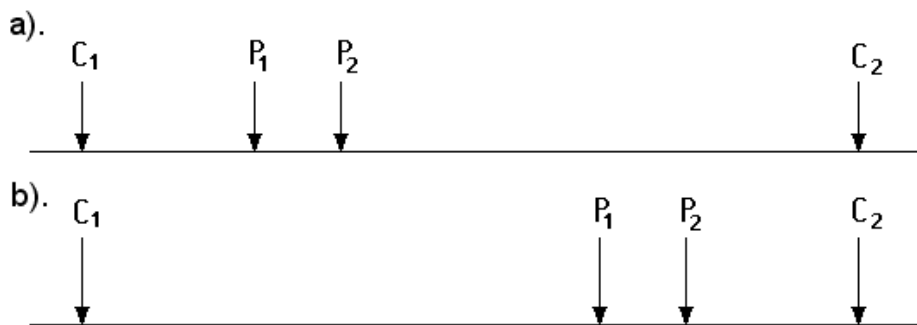

Figure 26. Two different configurations of the gradient array with the same pseudodepth but with the potential electrodes at different sides of the array. Gradient array configuration with (a) right parity and (b) left parity.

If the program finds that it is not practical to plot the profiles using the exact pseudodepth, it will automatically switch to the approximate pseudodepth method. For each C1-C2 spacing, the data is split up into several profiles that are plotted using different colors (Figure 27). Figure 28 shows the inversion model of the CROMER02.DAT data and the apparent resistivity pseudosections.

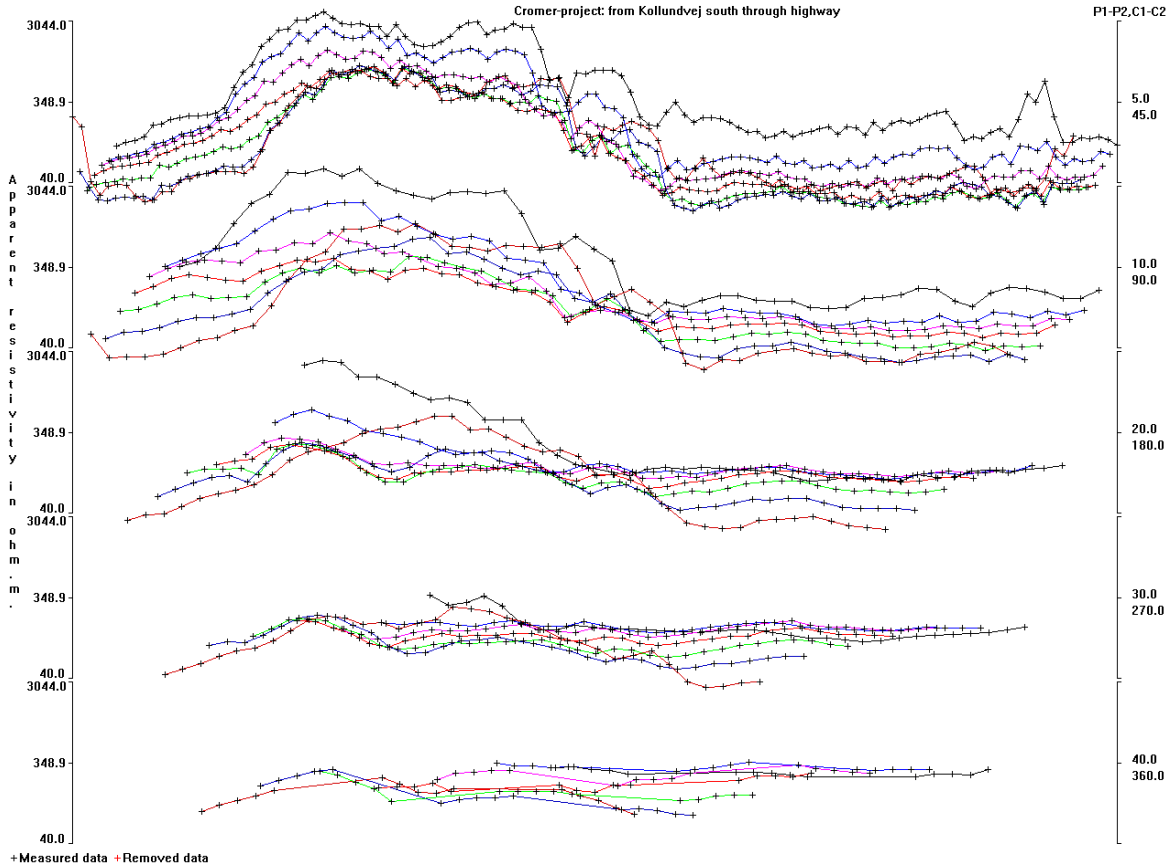

Figure 27. Plot of a CROMER2.DAT multiple gradient array data set in the form of profiles using the approximate pseudodepth method.

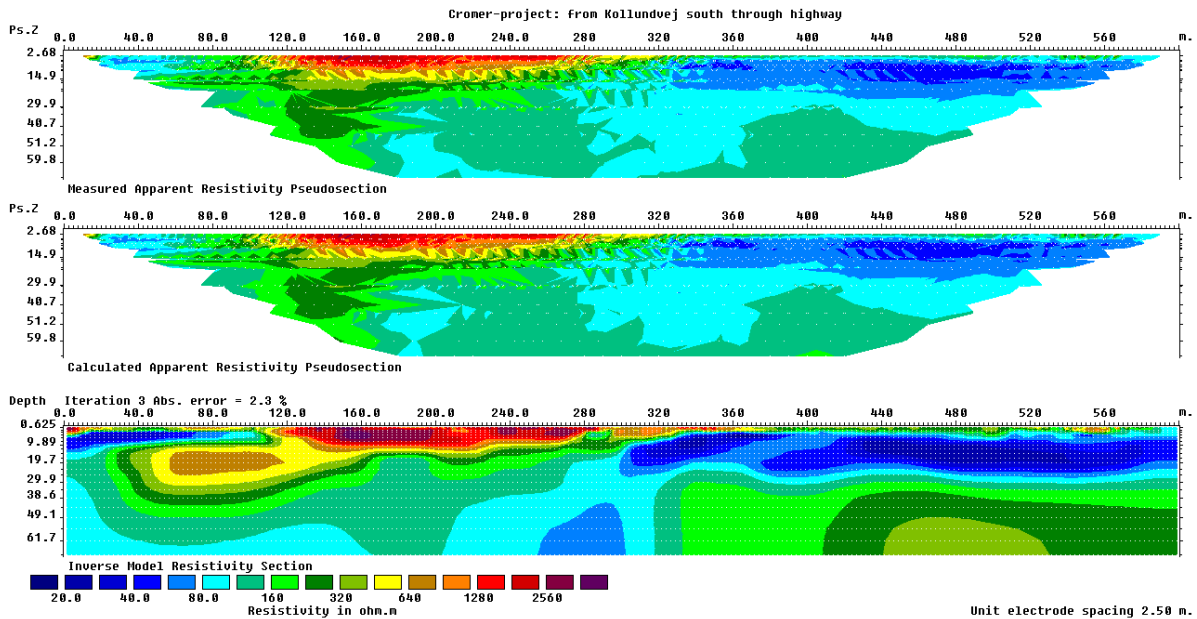

Figure 28. The inversion result of the CROMER02.DAT data set with the apparent resistivity and model sections.

10.5 Inversion parameters

You can save the inversion settings used in a text file so that the same settings can be used for different data sets. Note when the program starts up, it will automatically read the inversion parameters in a file RES2DINV.IVP located in the same folder as the RES2DINVx64 program which stores the default settings. You can change the default settings by changing this file.

10.5.1 Save inversion parameters

This option saves the inversion parameters into a file with the IVP.

10.5.2 Read inversion parameters

This option reads back the parameters stored in a file with the IVP extension and uses them in the program. RES2DINV_NEW.IVP is an example file that contains more inversion parameters. These files can also be used by the ‘Batch mode’ option.

11 Inversion menu options

This option enables you to carry out the inversion of the data set that you had read in using the "File - Read data file" option. You can also display the arrangement of the blocks used by the inversion model, as well as to change some of the parameters that control the inversion process. On selecting this option the following menu will be displayed.

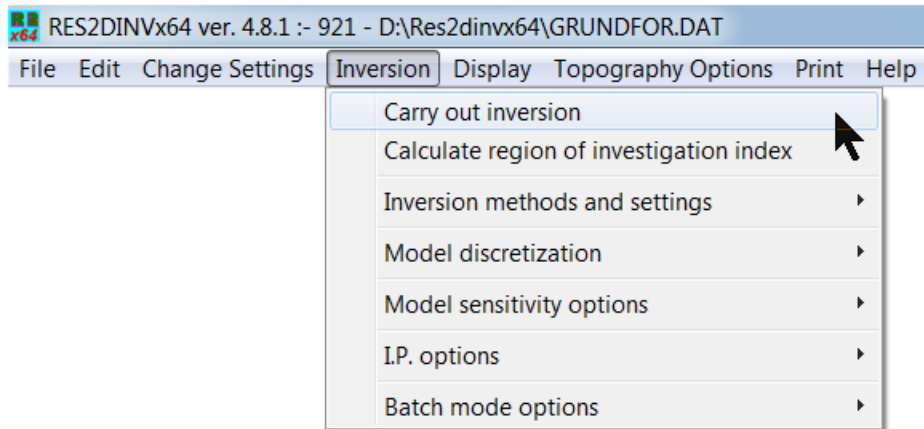

11.1 Inversion options

11.1.1 Carry out inversion

This option will start the least-squares inversion routine. You will be asked for the name of the output data file in which to store the results, and the contour intervals for the pseudosections if you had chosen the user defined option for the contour intervals. During the inversion process, after each iteration, the program will display the inverse model section on the screen. If a conventional array data set is used, the measured and calculated apparent resistivity pseudosections will also be displayed.

11.1.2 Calculate region of investigation index

This option carries out two inversions of the data file using different reference resistivity values (Oldenburg and Li 1999). To use it, first read in the data file, for example the beta.dat file. Next go to the 'Inversion' menu, click the second menu option from the top called 'Calculate region of investigation index'. If you had not earlier selected the settings to be used for the DOI calculation (see section 11.2.12) a dialog box with the list of parameters will be displayed. After setting the parameters, the program will then carry out the inversion of the data set twice using difference background reference models (section 11.2.5). The results will be saved in two files with an 'inv' extension. A record of the files will also be saved in a 'txt' file. This 'txt' file can be used in the 'Display' option to read in the two related 'inv' files for the DOI display. As an example, if the data file beta.dat was used, the program will produce the files beta_DOI1.INV, beta_DOI2.INV and beta_DOI_FILES.txt. Please refer to Appendix F for more details on the DOI calculation method.

11.2 Inversion Methods and Settings

These set of options allow you to select the type of regularized inversion method to use. The following list of sub-options will be shown on selecting this option.

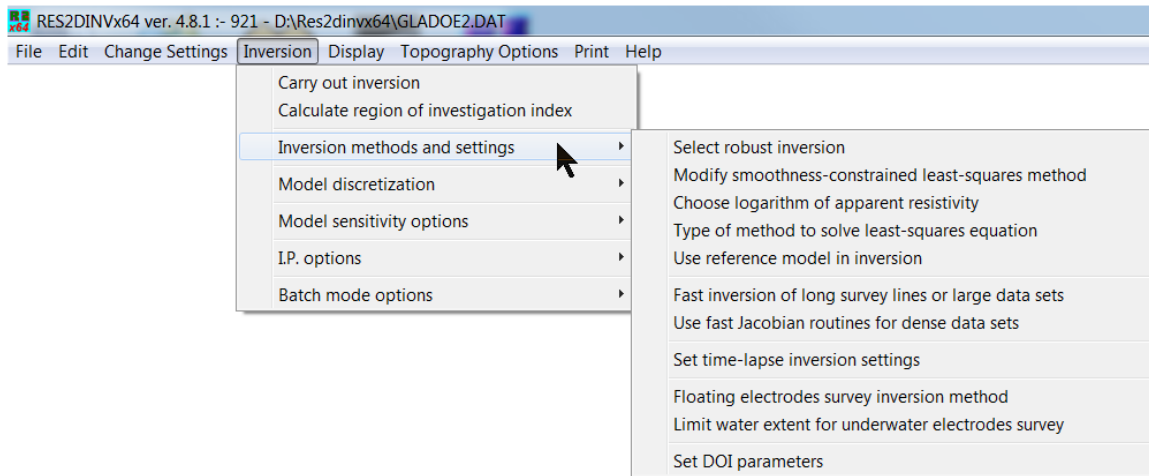

11.2.1 Select robust inversion

This allows you to select the smooth (L2 norm) or the robust/blocky (L1 norm) inversion method. Selecting this menu sub-option will bring up the following dialog box.

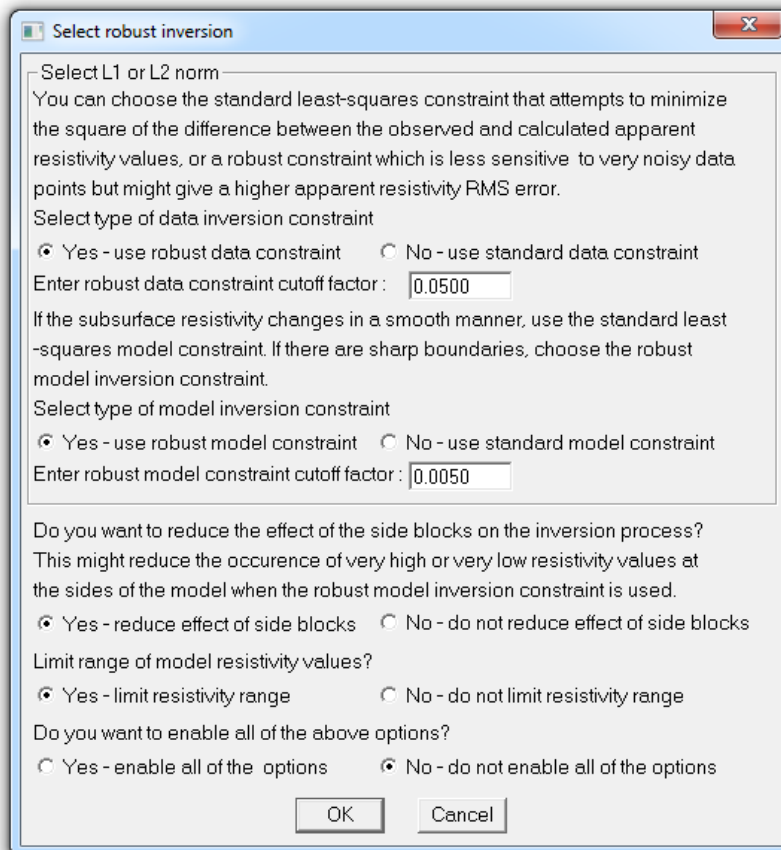

The conventional least-squares method ('standard data constraint') will attempt to minimize the *square* of difference between the measured and calculated apparent resistivity values. This method gives reasonable results if the data contains random or "Gaussian" noise. However, if the data set contains "outlier" data points (where the noise comes from non-random sources such mistakes or equipment problems), this method is less satisfactory. Such "outlier" data points could have a great influence on the resulting inversion model. To reduce the effect of such "outlier" data points, the L1 norm method ('robust data constraint') inversion method where the *absolute* difference (or the *first* power) between the measured and calculated apparent resistivity values is minimized can be used (Claerbout and Muir 1973).

There is a cut-off factor which controls the degree in which this robust data constrain is used. If a value of 0.05 is used, this means the effect of data points where the differences in the measured and calculated apparent resistivity values are much greater than 5 percent will be greatly reduced.

The conventional smoothness-constrained least squares method (deGroot-Hedlin and Constable 1990) also attempts to minimize the *square* of the changes (L2 norm) in the model resistivity values. This will produce a model with a smooth variation in the resistivity values. Such a model is more suitable where subsurface resistivity also changes in a smooth manner (Loke *et al.* 2003). However, if the subsurface bodies have sharp boundaries, such as the soil-bedrock interface or massive homogeneous bodies, the conventional least-squares smoothness-constrain method tends to smear the boundaries. If the robust model constrained inversion method is used, the program will attempt to minimize the *absolute* changes in the resistivity values. This constraint tends to produce models with sharp interfaces between different regions with different resistivity values, but within each region the resistivity value is almost constant. This might be more suitable for areas where such a geological situation exists, such as the soil-bedrock interface.

As an example, Figure 29 shows the inversion results for a synthetic model with a faulted block (with a resistivity of 50 ohm.m) in the bottom-left side and a small rectangular block (1 ohm.m) on the right side within a surrounding medium with a resistivity of 10 ohm.m. A test data set was generated for the Wenner array (Figure 29a). The model produced by the standard least-squares method has a gradational boundary for the faulted block (Figure 29b). In comparison, the model produced by the robust model inversion method has sharper and straighter boundaries (Figure 29c). A field example with sharp boundaries was shown earlier in Figure 14 for the Magusi River resistivity and IP data set. The main structure, the massive sulphide ore body, by nature has a distinct and sharp resistivity/IP contrast with the surrounding igneous/metamorphic country rocks. In the RES2DINVx64 program, this robust model option can be selected by clicking the “Robust model constraint” option in the “Select robust inversion” dialog box. There is a cut-off factor which controls the degree in which this robust model constrain is used. If a large value is used, for example 1.0, the result is essentially that of the conventional smoothness-constrained least-squares inversion method. If a very small value is used, for example 0.001, the result is close to the true L1-norm inversion method.

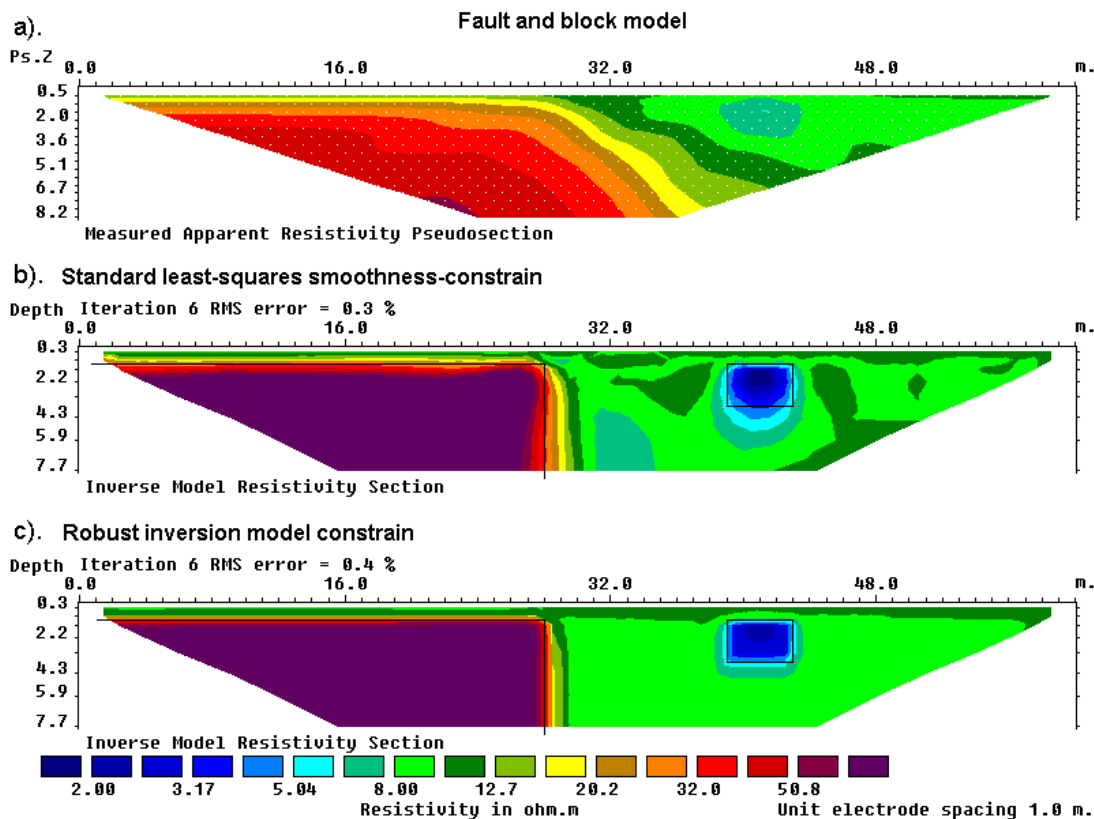
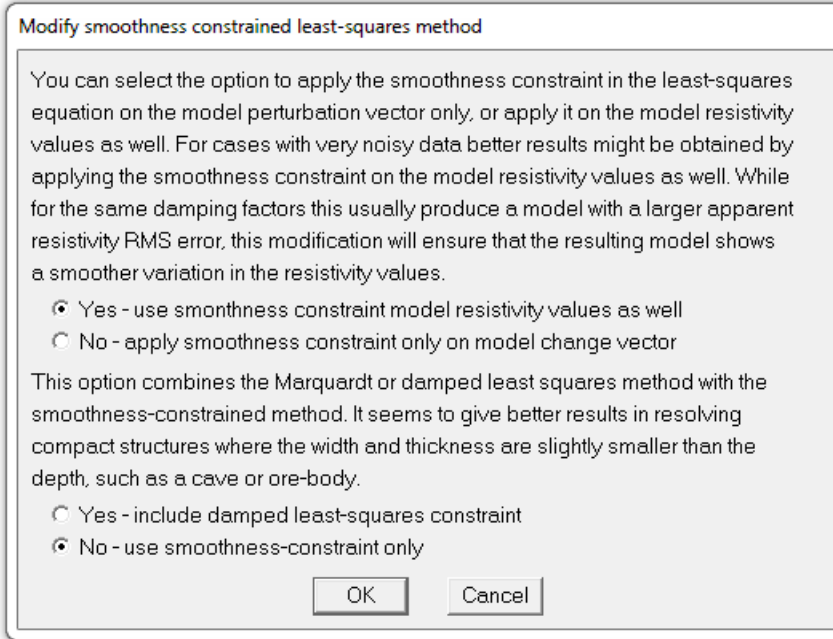

Figure 29. Example of inversion results using the smooth and robust inversion model constraint. (a) Apparent resistivity pseudosection. The inversion models produced by (b) the conventional least-squares smoothness-constrained method and (c) the robust or blocky inversion method.

11.2.2 Modify smoothness-constrained least-squares method

Selecting this option will bring up the following dialog box.



The first option in the dialog box allows the user to apply the smoothness constraint on the model change vector alone, or also on the model resistivity values. Applying the smoothness constraint on the model change vector alone modifies equation (4.1) to the following form which is used by some researchers (Sasaki 1992)

$$(\mathbf{J}^T \mathbf{J} + \lambda \mathbf{F}) \Delta \mathbf{q}_k = \mathbf{J}^T \mathbf{g}_k, \quad (11.1)$$

where $\Delta \mathbf{q}_k$ is the model parameter change vector.

This second option, combining the damped least squares method with the smoothness-constrained method, is intended for use in unusual situations where the data sensitivity values of the model blocks are significantly distorted by large resistivity variations. It modifies the least-squares equation to the following form.

$$(\mathbf{J}^T \mathbf{J} + \lambda (\mathbf{F} + \mathbf{I})) \Delta \mathbf{q}_k = \mathbf{J}^T \mathbf{g}_k - \lambda \mathbf{F} \mathbf{q}_k, \quad (11.2)$$

In some situations, such as a survey over a very low resistivity body, the current paths could be distorted such that parts of the subsurface are not well mapped and have very low data sensitivity values in the inversion model. This could lead to large distortions just below the low resistivity body. By combining the Marquardt (or ridge regression) and Occam (or smoothness-constrained) inversion methods, the distortions in some cases might be reduced. This option should be used as a last resort if everything else fails! It seems to give better results in resolving compact structures where the width and thickness are slightly smaller than the depth, such as a cave or ore-body whose size is just slightly less than its depth.

11.2.3 Choose logarithm of apparent resistivity

By default, the program will use the logarithm of the apparent resistivity values as the data parameter when carrying out the inversion. For most cases, this gives the best results. In some cases, for example with negative or zero apparent resistivity, this is not possible. This option enables the apparent resistivity value by itself to be used for such situations.

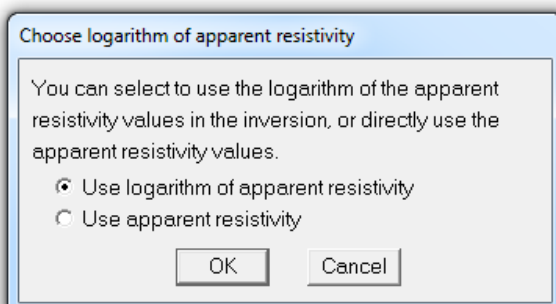

11.2.4 Type of method to solve least-squares equation

This option allows you to choose two different methods to solve the least-squares equation (4.1). On selecting this menu option, the following dialog box will be shown.

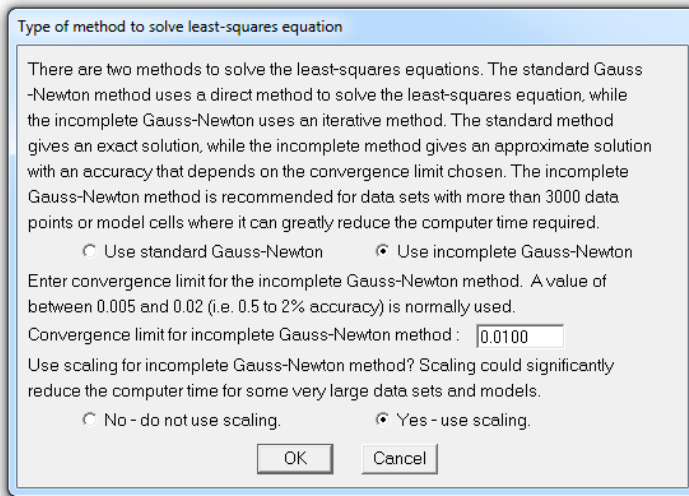

The 'Standard Gauss-Newton' least-squares method, that calculates an exact solution of the least-squares equation, should be used if the number of data points and/or model cells is small (less than a few thousand). If the number of data points and/or model cells is large (more than a few thousand), the time taken to solve the least-squares equation could be the most time-consuming part of the inversion process. To reduce the inversion time, an alternative method that calculates an approximate solution of the least-squares equation using the 'Incomplete Gauss-Newton' method can be used. This uses an iterative linear conjugate-gradient method to solve the least-squares equation. The user can set the accuracy of the solution. For most data sets, an accuracy of about 1% (i.e. a convergence limit of 0.01 in the above dialog box) seems to provide a solution that is almost the same as that obtained by the 'Standard Gauss-Newton' method. Setting a higher accuracy, for example 0.5%, will in theory give a result that is even closer to the 'Standard Gauss-Newton' method but this is at the expense of a longer inversion time. The incomplete Gauss-Newton method has an option to scale the matrices in order to improve the convergence of the iterative method used.

11.2.5 Use reference model in inversion

The least-squares equation (4.1) minimizes a combination of the model smoothness and the data misfit. Sometimes, an additional constraint is used where the model must be 'close' to some reference model as shown below.

$$(\mathbf{J}^T \mathbf{J} + \lambda(\mathbf{F} + \mu \mathbf{I})) \Delta \mathbf{q}_k = \mathbf{J}^T \mathbf{g} - \lambda \mathbf{F} \mathbf{q}_k - \lambda \mu (\mathbf{q}_k - \mathbf{q}_m) \quad (11.3)$$

An additional damping factor μ that controls the degree where the inversion model is 'close' to a reference model \mathbf{q}_m is used. The reference model is usually a homogeneous half-space model. The following dialog box shows the settings that can be selected by the user.

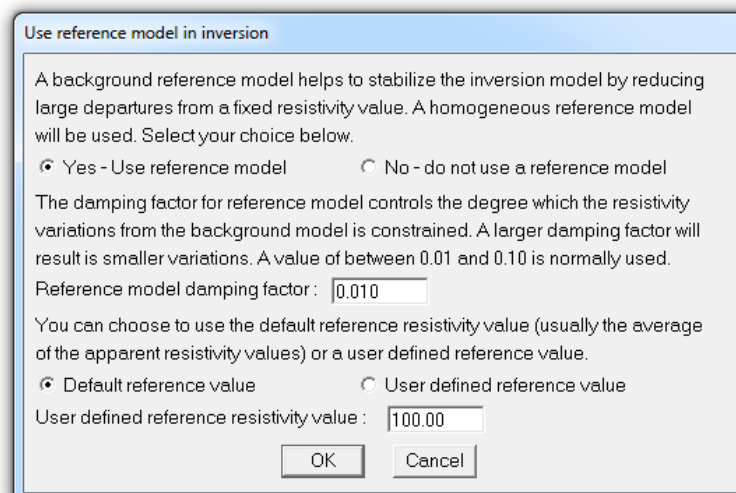

The user can set the damping factor (μ) as well as the resistivity for the reference model. By default, the program will use the average of the apparent resistivity values as the constant resistivity reference model. However, this reference resistivity value can be changed by the user.

11.2.6 Fast inversion of long survey lines

Clicking the 'Fast inversion of long survey lines' menu option will display the following dialog box.

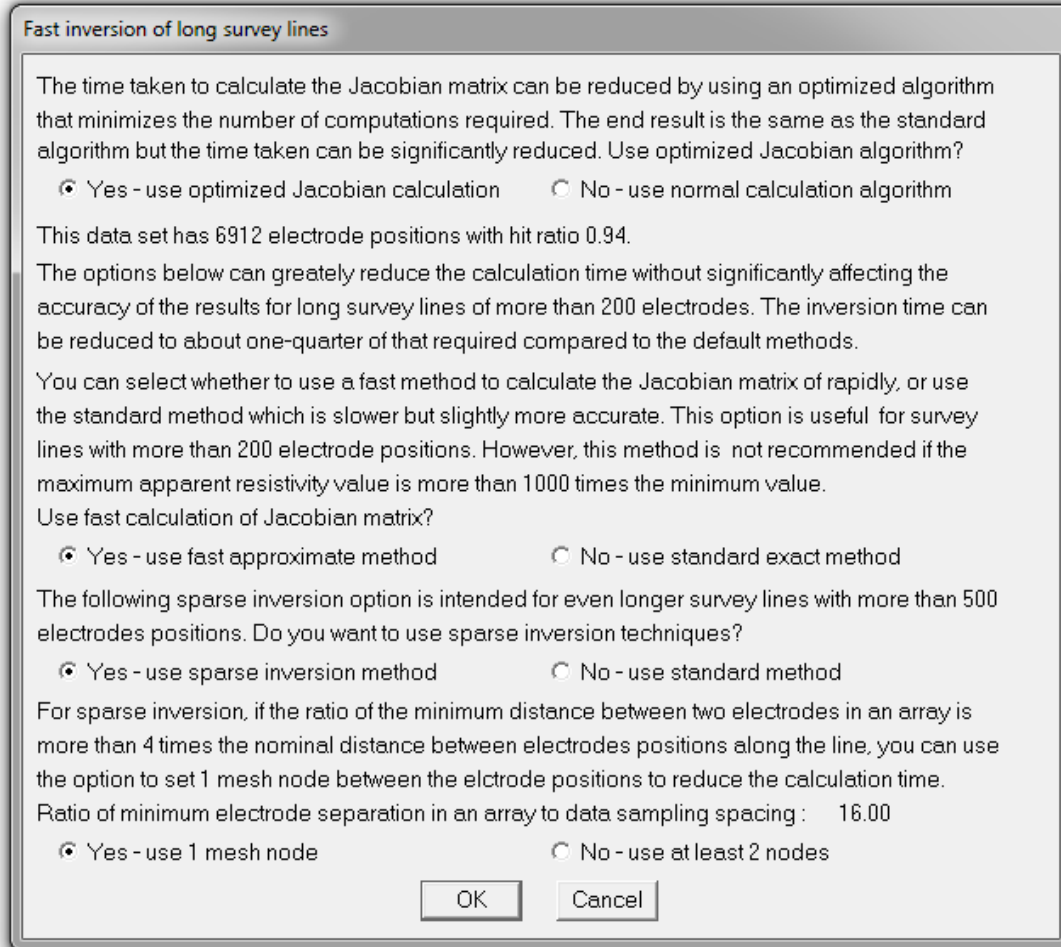

The first option is to use an optimized method to calculate the Jacobian matrix. This can significantly reduce the calculation time without affecting the accuracy of the values and should give the same inversion model as the default method.

The second method is to use a fast method to calculate the Jacobian matrix by excluding the model cells that are far away from the electrodes used in an array. The Jacobian matrix values and thus the inversion model will be slightly different from that obtained using the standard method, but the difference is normally small (less than 5%).

The third method, using sparse inversion techniques, is intended for long survey lines with 500 electrodes positions or more. This method will still produce a contiguous model along the entire survey line but takes advantage of the sparse nature of the Jacobian matrix to reduce the number of calculations needed. The results will be slightly different (usually less than 5%) from that obtained using the standard method. If the sparse inversion method is selected, the user can choose the option to set 1 horizontal mesh node between adjacent electrode positions. This should only be used if the data collection interval is much less than the spacing between the electrodes in an array. This normally occurs when a mobile system is used for the data collection. As an example, an OhmMapper system might use a spacing of 5 meters between the dipoles in the cable setup. However, it is possible to take readings at every 1 meter by pulling the system along the ground surface. In this case, the data sampling interval is one-fifth the spacing between the electrodes in a single array. The inversion time can be reduced by slightly more than half by setting a 1 node interval between the electrodes positions occupied compared to the default 2 nodes option.

11.2.7 Use fast Jacobian routines for dense data sets

This option uses an optimized routine for calculating the Jacobian matrix values for data sets where the number of data points is much greater than the number of electrodes used in making the measurements. It uses an alternative algorithm to calculate the Jacobian matrix values which can be significantly faster than the standard routines. The expected reduction in the calculation time for the Jacobian matrix will be displayed in the dialog box. As a guide, this option should only be used when the expected reduction is more than 20%. Note for some very sparse data sets, this routine can be even slower than the standard method. This will be indicated by a negative value for the expected reduction in the calculation time.

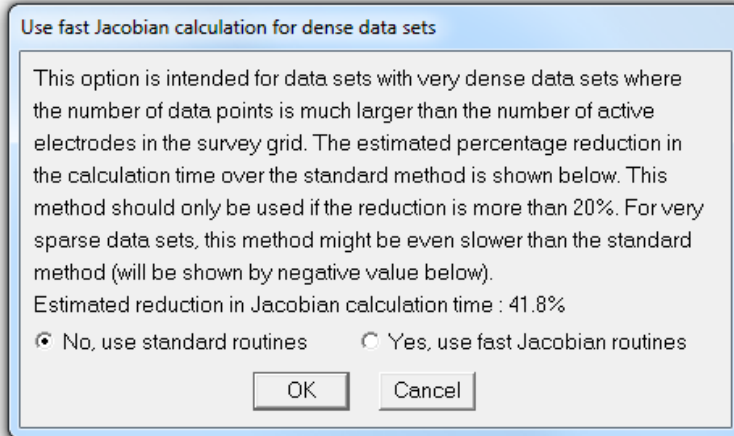

If this option is selected, the first two settings in the previous option ‘Fast inversion of long surveys lines’ will be automatically turn off.

11.2.8 Set time-lapse inversion settings

To study the changes of the subsurface resistivity with time, 2-D surveys are repeated over the same line at different times. Such studies include the flow of water through the vadose zone, changes in the water table due to water extraction (Barker and Moore 1998), flow of chemical pollutants and leakage from dams. The settings used by the inversion method are shown below.

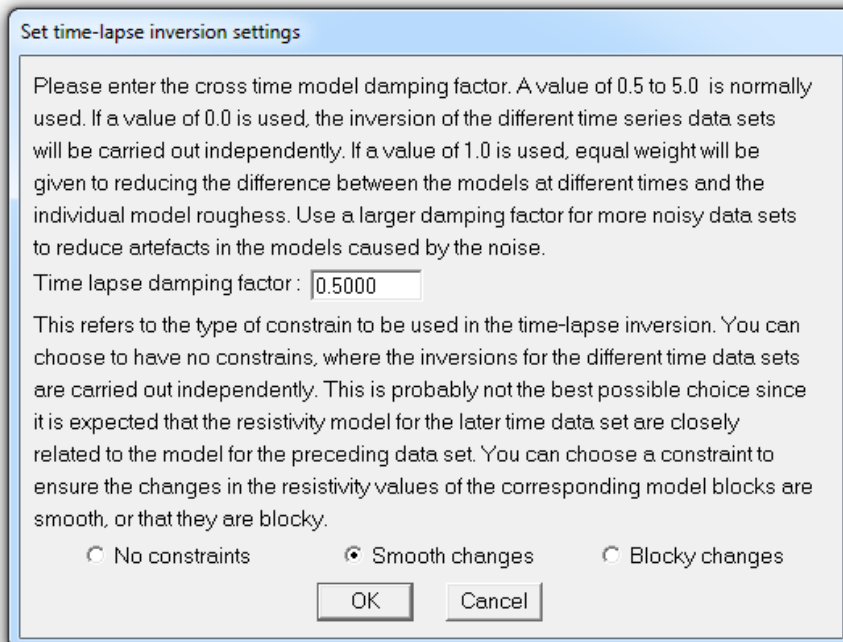

The time-lapse inversion equation (Kim *et al.* 2009) is given by

$$[\mathbf{J}_i^T \mathbf{J}_i + \lambda(\mathbf{F} + \alpha \mathbf{M}^T \mathbf{R}_t \mathbf{M})] \Delta \mathbf{q}_k = \mathbf{J}_i^T \mathbf{g}_i - \lambda(\mathbf{F} + \alpha \mathbf{M}^T \mathbf{R}_t \mathbf{M}) \mathbf{q}_k \quad (11.4)$$

The relative importance given to minimizing the difference between models at different times is controlled by the time lapse damping factor α . A larger value of the time-lapse damping factor will force the different time models to be more similar but at the expense of a larger data misfit (Rucker *et al.* 2011a). The user can also modify the time-difference roughness filter to select smooth or blocky differences between the time models (Kim 2010; Loke *et al.* 2014).

11.2.9 Floating electrodes survey inversion method

This set of options is for data from a survey with floating electrodes where the thickness and resistivity of the water layer was measured during the survey. On clicking this sub-option, the following dialog box is displayed.

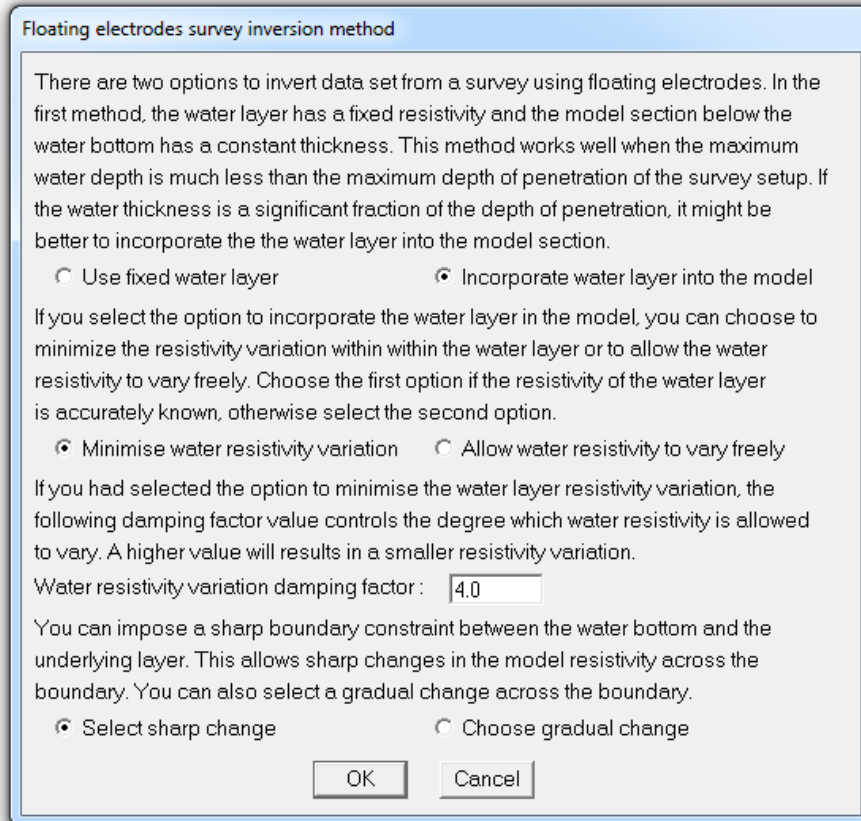

There are two methods that can be used for the inversion of the data set. The first method (Use fixed water layer) is more suitable when the maximum thickness of the water layer is small (less than 20%) compared to the maximum depth of investigation of the survey configuration. Figure 30 below shows the inversion of the WATER_FLOAT.DAT data set using this method. A distorted finite-element grid is used to model the water layer. The maximum thickness of the water layer in this example is 2.5 meters that is small compared to the maximum depth of investigation at about 15 meters for the data set.

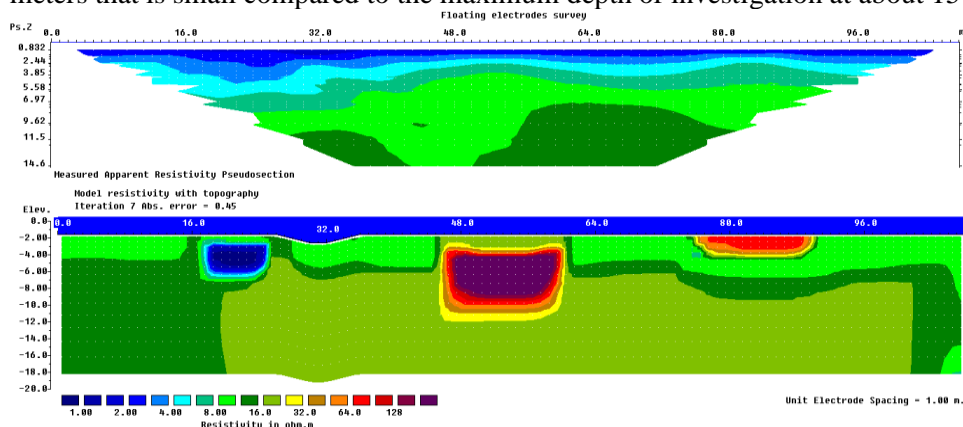

Figure 30. Example of inversion model with a fixed water layer. The inversion results of the WATER_FLOAT.DAT data is shown where the resistivity water layer (represented by the top blue layer in the model section) is fixed and model extends from below the water bottom.

In cases where the thickness of the water layer is significant, a second inversion method (Incorporate the water layer into the model) is more suitable. The water layer section is included into the inversion model. This method has two inversion settings. In most cases, the resistivity of the water layer does not vary significantly along the survey line or with depth. Thus, normally the option ‘Minimize variation of water resistivity’ is selected. However, to accommodate cases where there are significant variations in the water resistivity (such as in a mixing zone between fresh and saline water), the option ‘Allow water layer resistivity to vary freely’ can be used.

The subsurface material below the water layer frequently has a much higher resistivity than the water. The option ‘Select a sharp change across the water bottom boundary’ can be used so that a sharp contrast is allowed between the water layer and the subsurface. This option uses the method described in section 7.10. The program automatically adjusts the thickness of the model layers and divides the model cells into those belonging to the water layer and the subsurface. Figure 31 shows the arrangement of the model cells for one of the survey lines along the São Francisco River, that divides the Bahia (BA) and Pernambuco (PE) states, near the Santa Maria da Boa Vista city (PE), northeast of the Brazil (Rodrigo Machado pers. Comm.). In this survey, a dipole-dipole type of configuration was used with 5 meter dipoles. However, the readings were taken every meter that gives a data set with a nominal unit electrode spacing of 1 meter. To reduce the number of model cells and taking in consideration that the resolution of such a survey is very unlikely to be better than half the dipole length, the width of the model cells was set at 3 times the unit electrode spacing (section 11.3.7), i.e. basically 3 meters for almost the entire section. Also, note that the depth of the water at some places is greater than maximum median depth of investigation (as indicated by the data points markers). However, the program sets the depth of the layers such that there is at least one model layer below the water bottom (represented by the dark blue line). The cells below the water layer are marked as light blue in the figure below. A sharp resistivity variation is allowed in the inversion method used between the two sections.

The apparent resistivity pseudosection and inversion model for this data set is shown in Figure 32. In this inversion, the resistivity variation within the water layer was minimized. Thus, the water layer resistivity is generally uniform except towards the left end of the survey line where there is not much data. There is also an indication that between the 190 and 220 meter marks, the near-surface riverbed material consists of low resistivity sediments.

Surveys with floating electrodes are frequently carried out using a cable with a number of electrodes pulled behind a boat, usually with a multi-channel resistivity-meter system controlled by a computer linked to a GPS system. A 5 meter spacing between the electrodes takeouts is commonly used together a dipole-dipole type of array configuration (not necessary symmetrical). The boat moves continuously and the measurements can be made at arbitrary intervals although the dipole length is 5 meters. Frequently, the measurements are digitized to every 1 meter position. Thus, the active electrode positions are 1 meter apart that is much smaller than the dipole length of 5 meters. This can result in very long survey lines, and very large inversion models with the default settings of the inversion program. A number of options have been added to the program to reduce the inversion time for such data sets.

The resolution of the survey setup is unlikely to be very much better than the dipole length particularly if there is water layer of significant thickness between the cable and the subsurface. The program normally uses a model where the widths of the model blocks are set to be the same (or half) as the distance between the electrode positions along the line. This is reasonable for normal land surveys with a static cable setup. For floating electrodes survey, since the distance between the electrodes positions (1 meter) is much smaller than the dipole length (5 meters), this results in a model that is too fine. To avoid this, use the option under the ‘Inversion – Model Discretization – Change width of blocks’ menu described in section 11.3.7. Since the horizontal resolution of the data is unlikely to be better than half the dipole length, it is recommended that the width of the model cells be set at 3 times the unit electrode spacing (for the situation with 5 meter dipoles and 1 meter data spacing). This will greatly reduce the number of model cells in the inversion model. The time taken to calculate the apparent resistivity (and the corresponding Jacobian matrix) can be greatly reduced by using the ‘sparse inversion’ method described in section 11.2.6.

It is assumed that the survey line is straight when a 2-D inversion approach is used. In cases where there are strong water currents this is no longer true so there will be distortions in the resulting inverse model. If there are significant deviations in the direction of the survey line, a better method will be to use a 3-D approach in modeling the data (Rucker *et al.* 2011b).

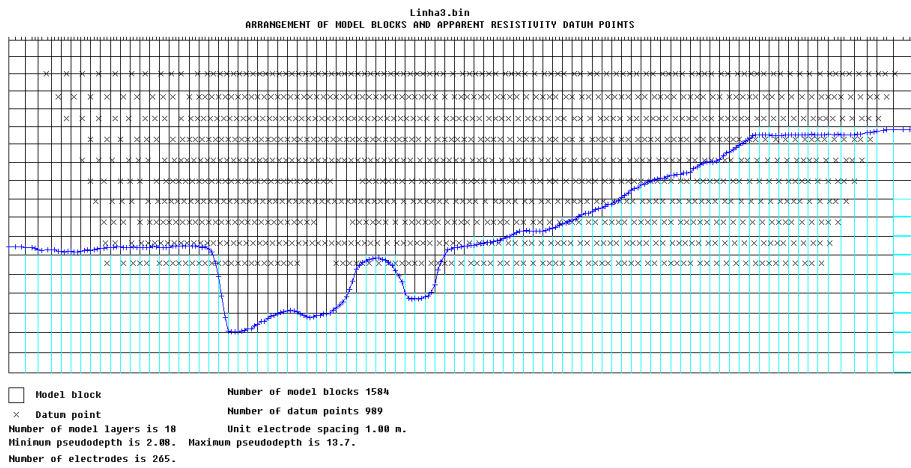

Figure 31. Arrangement of model blocks and the water bottom boundary for an arrangement with the water layer incorporated into the inversion model.

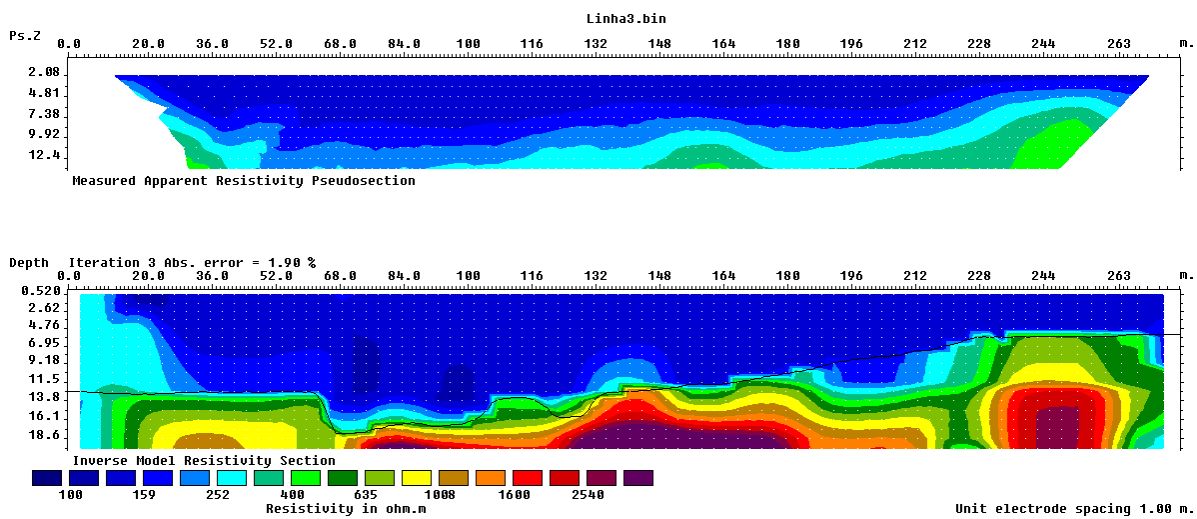
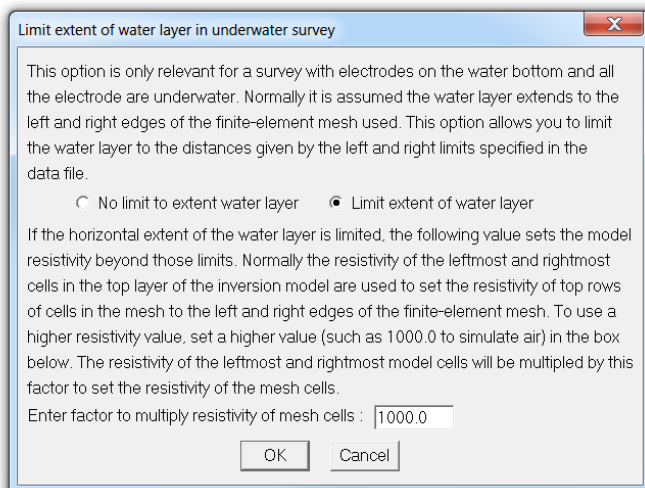

Figure 32. Inversion model for the survey with floating electrodes along the along the São Francisco River in Brazil. The thin black line indicates the water bottom boundary.

11.2.10 Limit water extent for underwater electrodes survey

This option can only used if you had read in a data file with underwater electrodes and where the limits of the water layer was less than the line length, such as a survey across a dam or levee. When the program reads in such a data file, it will automatically enable the option to limit the extent of the water layer based on the left and right limits set in the data file. This option also allows the user to set the resistivity of the mesh cells outside the water covered region using the dialog box below.



11.2.11 Set DOI parameters

This option allows the user to set the settings for the calculation of the depth of investigation (DOI) calculation. The DOI method is based on carrying out the inversion of a data set using two different background reference models (Oldenburg and Li 1999). Normally the first and second reference models are set at one-tenth and ten times the average apparent resistivity value. In areas where the inversion models are well constrained by the data, the inverse model values should be similar. In areas with little information, the inverse model values will be largely determined by the reference model used. The various inversion settings can be set using the dialog box below.

Reference model resistivity multiplication factor : This sets the resistivity value for the reference model used in the two inversions. The reference model resistivity used is the multiplication factor multiplied by the average apparent resistivity value (which is the default reference resistivity value). For example, if the average apparent resistivity value is 100 ohm.m, the program will use reference resistivity values of 10 and 1000 ohm.m respectively for the first and second inversions (assuming the default values of 0.1 and 10 are used for the multiplication factors).

Optimize inversion parameters for DOI calculation : This will automatically set the optimum inversion parameters (such as the thickness and number of layers, damping factors) for calculating the DOI.

Damping factor for reference model : This sets the damping factor that constrains the inversion model resistivity to the background reference resistivity model. Normally a value of between 0.01 and 0.10 is used.

Background reference model : As an alternative to using the multiplication factors to set the low and high reference resistivity models, this option allows the user to directly specify the reference resistivity values.

Type of inversion method : The smooth or L2 norm inversion method should normally be used for the DOI calculations. This generates relatively smooth DOI sections. The robust (or L1 norm) method tends to produce models with sharper boundaries. This can cause problems in the DOI distribution as a small mismatch in the boundary can cause spurious large DOI values near the boundaries.

Factor to extend depth range : The success of the DOI method depends on extending the depth to the deepest layer well beyond the region where data has a significant influence on the inversion results, i.e. where the DOI is expected to approach 1.0. To ensure this, the depth range of the model should be extended several times the maximum median depth of investigation of the data set. Using a larger factor will increase the number of model cells and thus the computer time, so a value of about 3.0 is normally used. This option only affects the model for surface surveys, i.e. it does not affect the model used for borehole surveys where the number and depth of the layers is determined by the borehole electrodes. To extend the depth range for the model used for borehole surveys, you will need to add 'dummy' borehole electrodes in the data file below the 'active' borehole electrodes.

Number of iterations : For the DOI calculations, it is recommended that a small number of iterations should be used (usually about 3). The reason is that if a large number of iterations is used, the inversion

process attempts to fit the noise in the data in the later iterations. This can cause anomalous model resistivity values which in turn cause distortions in the DOI pattern.

11.3 Model discretization

These options allow you to modify the way the program subdivides the subsurface into cells that is used as the inversion model. The following list of sub-options will be displayed when this option is selected.

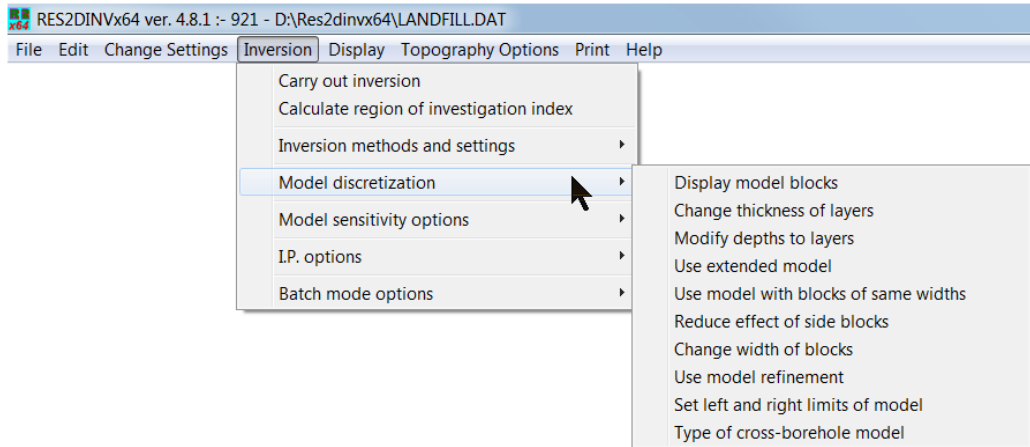

11.3.1 Display model blocks

This option will display the distribution of the model blocks and data points. The data points will be plotted at the median depth of investigation (Edwards 1977) for the array used. Figure 33 shows three possible arrangements of the model blocks for the same data set.

11.3.2 Change thickness of layers

In this option, you can set the thickness of the layers used in the inversion model by setting the thickness of the first layer and the rate at which the thickness of each successive deeper layer increases, as shown by the following dialog box.

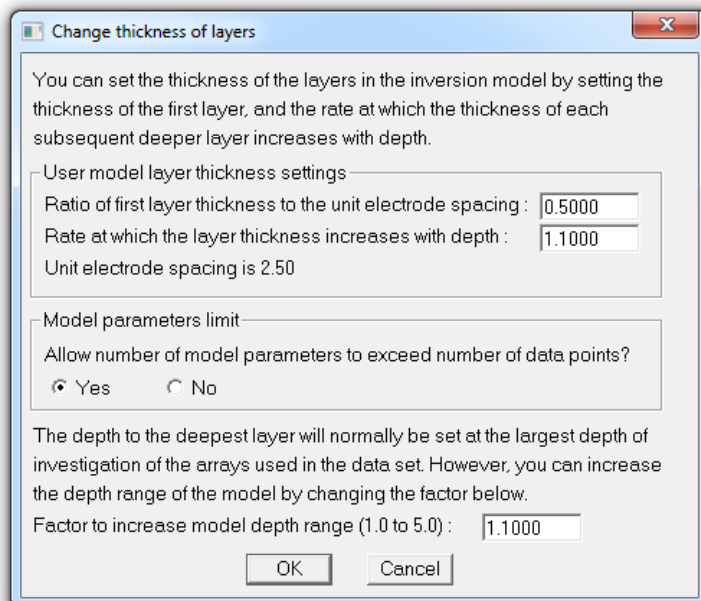

When the program reads in a data file, it will normally set the first layer thickness using the minimum pseudodepth of the data points. For surface surveys, since the resolution decreases with depth, the thickness of the layers is normally increased by between 5 to 15 % with each deeper layer. The program normally uses a model where the depth to the deepest layer does not exceed the maximum pseudodepth in the data set. To use a model that spans a deeper depth range, you can change the factor to increase model depth range, for example from 1.0 to 1.30 to increase the model depth range by 30%.

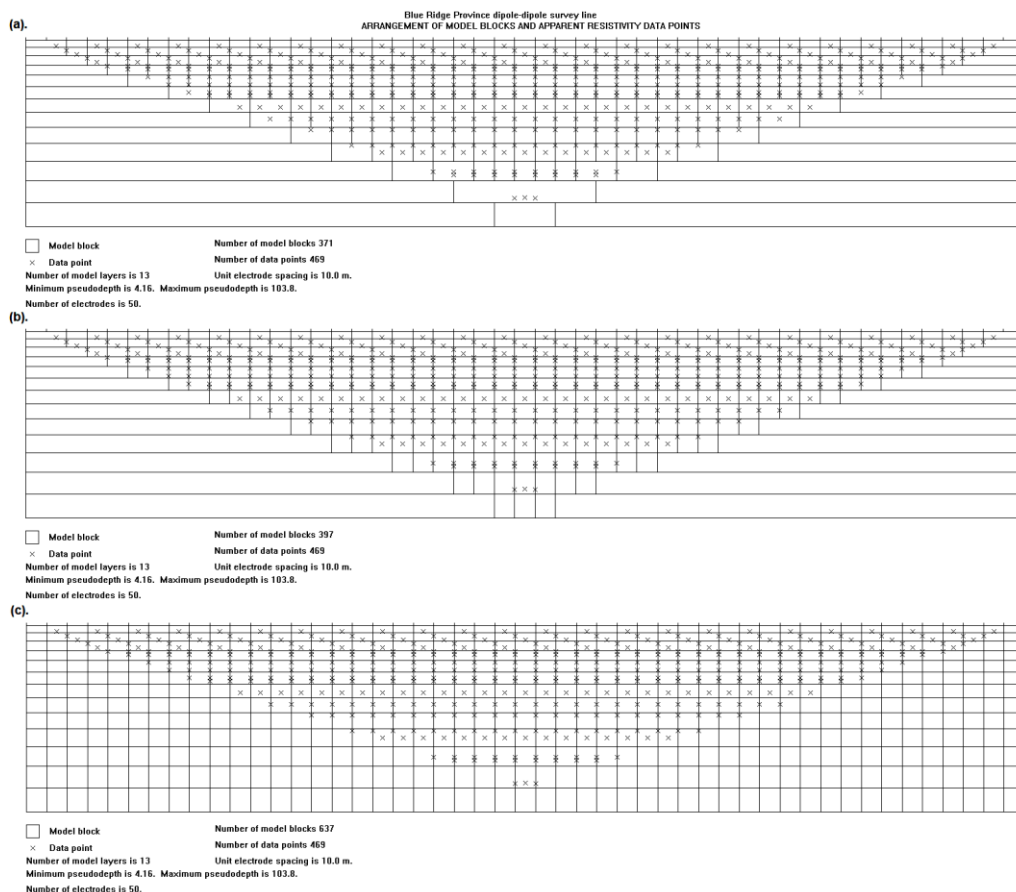

Figure 33. Different possible arrangement of model blocks for the same data set. (a) Using wider blocks at sides and bottom, (b) blocks of equal width, (c) model blocks extended to ends of survey line.

11.3.3 Modify depths to layers

This option allows you to change the depth of each individual layer used by the inversion model. You can adjust the depths manually so that some of the boundaries coincide with known depths from borehole or other data. The following dialog box will be displayed when this option is selected. In the box, the depths to the layers are listed. The depths listed can be changed manually.

Modify depth of layers X

Layer	New Depth	Present Depth	Layer	New Depth	Present Depth
1	5.00	5.00	21		None
2	10.5	10.5	22		None
3	16.5	16.5	23		None
4	23.2	23.2	24		None
5	30.5	30.5	25		None
6	38.6	38.6	26		None
7	47.4	47.4	27		None
8	57.2	57.2	28		None
9	67.9	67.9	29		None
10	79.7	79.7	30		None
11	92.7	92.7	31		None
12	106.9	106.9	32		None
13	122.6	122.6	33		None
14		None	34		None
15		None	35		None
16		None	36		None
17		None	37		None
18		None	38		None
19		None	39		None
20		None	40		None

Depth scaling factor:

11.3.4 Use extended model

By default, the program uses the arrangement of the data points in the pseudosection as an approximate guide in discretizing the subsurface into rectangular blocks (Figure 33a). This option extends the model cells to the edges of the survey line (Figure 33c) using the following dialog box.

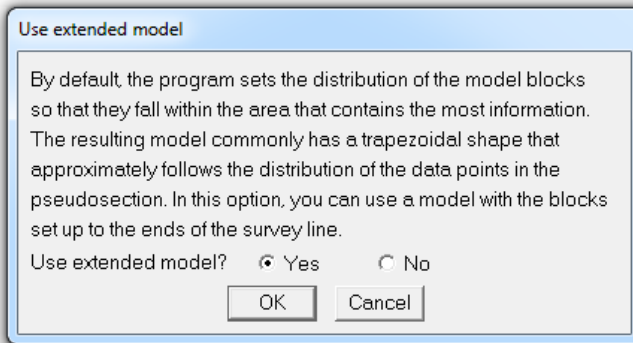

11.3.5 Use model with blocks of same widths

The model shown in Figure 33a has model cells that are wider at the edges. The first option in the dialog box shown below will ensure that all the cells have the same width that is equal to the unit electrode spacing (Figure 33b).

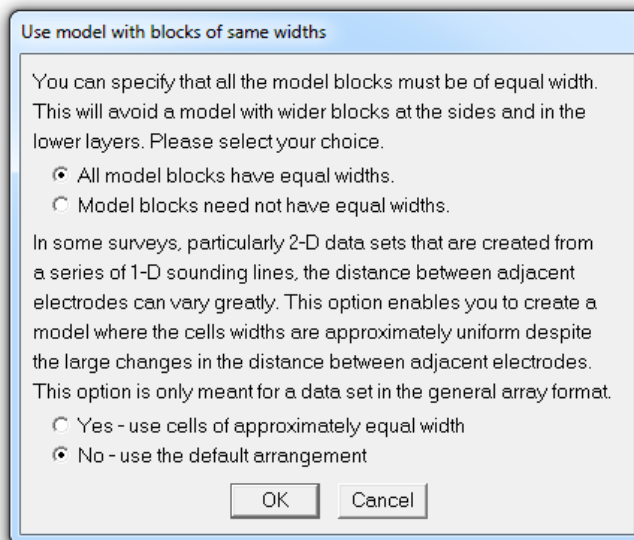

The second option is intended for data sets created from a series of overlapping 1-D sounding lines. Such data sets can have great variations in the distances between the electrode positions. This option allows the user to use a model with model cells of more uniform width.

11.3.6 Reduce effect of side blocks

This option affects the calculation of the Jacobian matrix values for the model blocks located at the sides and bottom of the model section. Normally, for a block located at the side, the contributions by all the mesh elements associated with the model block are added up right to the edge of the mesh. This gives a greater weight to the side block compared to the interior blocks. In some cases, particularly when the robust inversion option is used, this can result in unusually a high or low resistivity value for the side block. This option limits the contribution of the mesh elements outside the ends of the survey line to the Jacobian matrix values for the side blocks. The following dialog box shows the different degrees the contribution of the cells outside the survey line to the Jacobian matrix values are truncated.

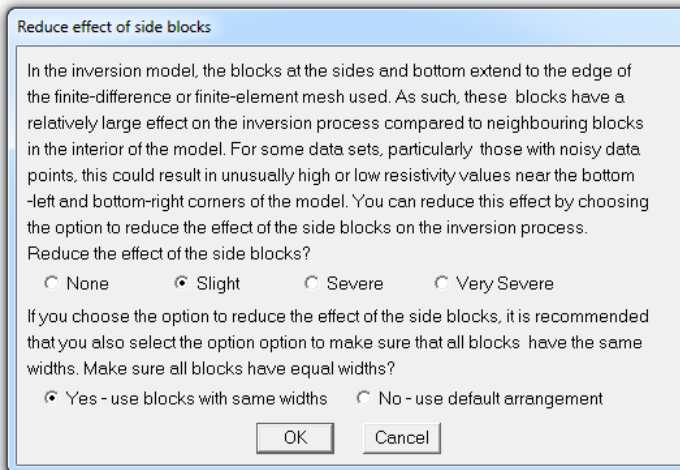

11.3.7 Change width of blocks

This option allows the user to force the program to use model cells that are wider than one unit electrode spacing for all the layers. It is mainly intended for data collected from mobile surveys where a cable with fixed electrodes positions is dragged along during the survey. The distances between the measurement points are often much less than the spacing between the electrode takeouts. In the following dialog box the model blocks widths can be set to 1 to 15 times the unit electrode spacing.

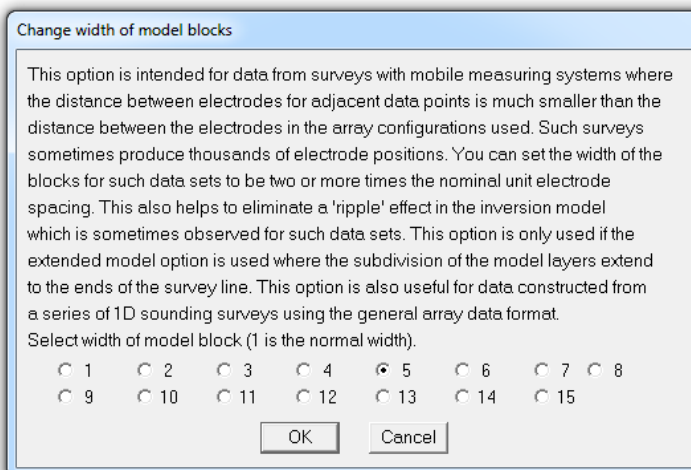

11.3.8 Use model refinement

The RES2DINV program by default uses a model where the width of the interior model blocks is the same as the unit electrode spacing. This works well in most cases. In situations with large resistivity variations near the ground surface better results can be obtained by using narrower model cells. There are two possible ways to reduce the width of the model cells. The first is by using the "Use model refinement" option on the "Inversion" menu. Clicking this option will show the following dialog box.

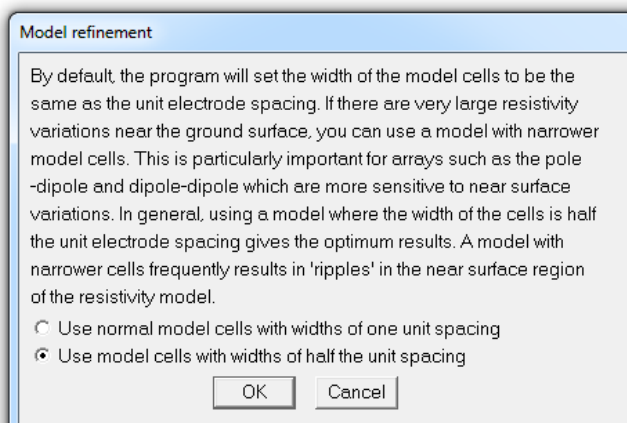

This allows you to choose model cells with widths of half the unit electrode spacing. In almost all cases, this gives the optimum results. After selecting this option, you must read in the data file. The program will then automatically reduce the unit electrode spacing it uses by half of that given in the data file. The second method is to modify the data file directly using a text editor. The unit electrode spacing is given in the second line of the apparent resistivity data file. For example, the first few lines of the PIPESCHL.DAT file are reproduced in Table 38. In the second data line, the unit electrode spacing is given as 1.0 meter that is the actual spacing used in this survey. When the RES2DINV reads in this data file, it will set the width of the model cells to 1.0 meter. The file PIPESCHL_HALF.DAT has the same data except that the unit electrode spacing is now defined as 0.5 meter. The upper part of this file is shown in Table 38.

When the RES2DINV program reads this file, it will set the model blocks to 0.5 meter width. Figure 34 shows the inversion models for this data set using cells with widths of 1.0 and 0.5 meter. The model with the 0.5 meter block width is able to more accurately model the high resistivity anomalies near the surface between the 3 and 12 meter marks above the pipe, and thus has a slightly lower apparent resistivity RMS data misfit. In most cases with large resistivity variations near the surface, using a model with a cell width of half the actual unit electrode spacing is sufficient. In some cases, using a narrower cell width of one-third or one-quarter the unit might be justified, particularly if the survey was carried out using a pole-dipole or dipole-dipole array with very high 'n' factors. If the cell width is one-quarter the true unit electrode spacing, or less, oscillations in the model resistivity values in the first few layers can occur. Thus, the use of a cell width of less than one-quarter the true unit electrode spacing is not advisable.

Table 38. Data file with standard unit electrode spacing.

<i>PIPESCHL.DAT file</i>	<i>Comments</i>
Underground pipe survey	<i>Title</i>
1.00	<i>Unit electrode spacing</i>
7	<i>Wenner-Schlumberger array</i>
173	<i>Number of data points</i>
1	<i>Mid-point given for x-location</i>
0	<i>No I.P.</i>
1.50 1.00 1 641.1633	<i>First data point</i>
0.0	<i>Coordinates of the first electrode</i>
..	<i>The rest follows the usual data format</i>

Table 39. Data file with half the standard unit electrode spacing.

<i>PIPESCHL_HALF.DAT file</i>	<i>Comments</i>
Underground pipe survey	<i>Title</i>
0.50	<i>Half the actual unit electrode spacing</i>
7	<i>Wenner-Schlumberger array</i>
173	<i>Number of data points</i>
1	<i>Mid-point given for x-location</i>
0	<i>No I.P.</i>
1.50 1.00 1 641.1633	<i>First data point</i>
0.0	<i>Coordinates of the first electrode</i>
..	<i>The rest follows the usual data format</i>

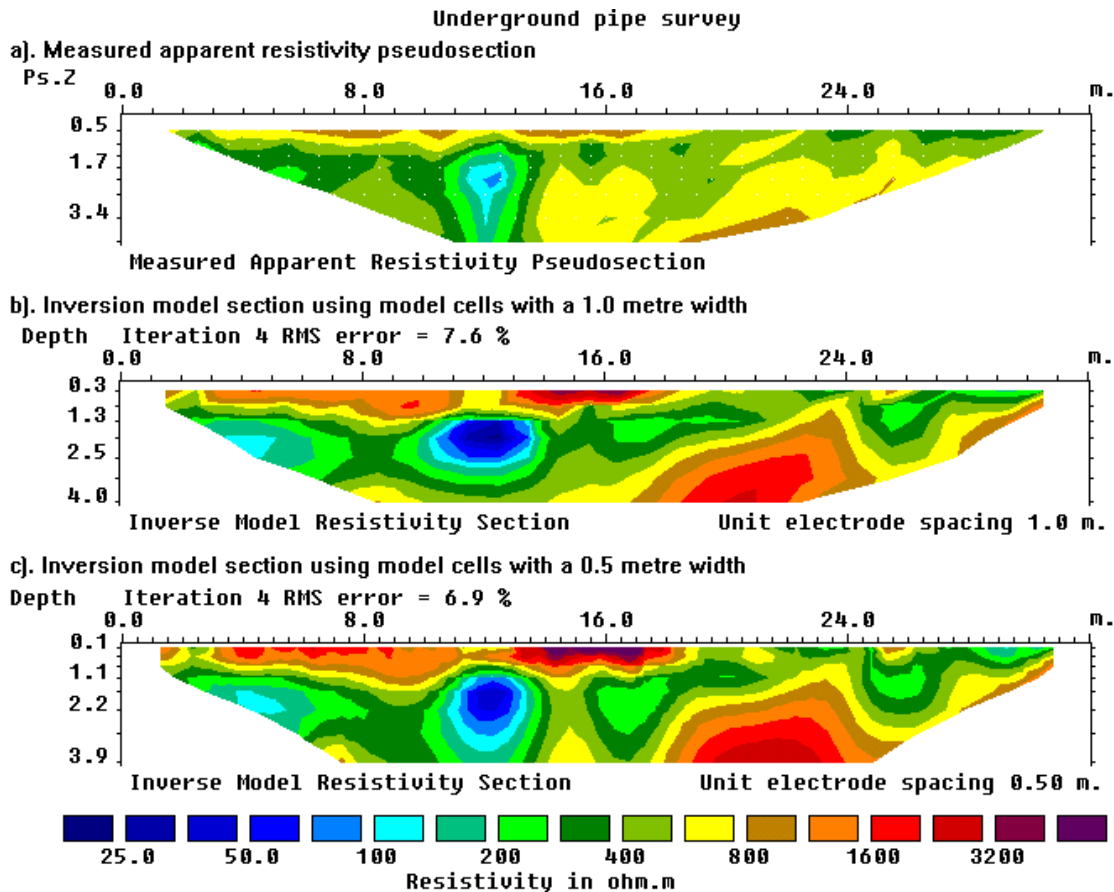
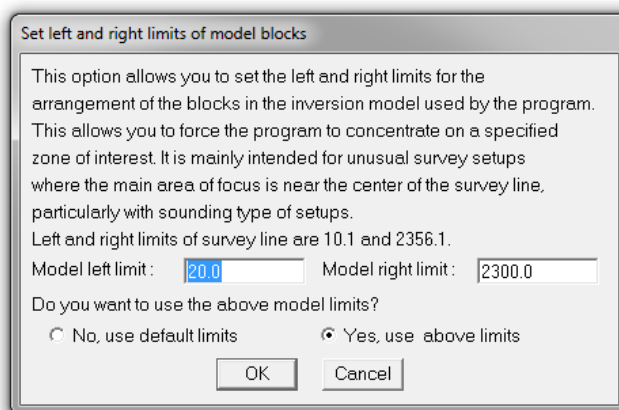

Figure 34. Example of inversion models using the standard and half-sized model blocks. (a) The apparent resistivity pseudosection for the PIPESCHL.DAT data set. The inversion models using (b) blocks with a width of 1.0 meter that is the same as the actual unit electrode, and (c) using narrower blocks with a width of 0.5 meter.

11.3.9 Set left and right limits of model

This option can only be used for input data in the general array format. It allows the user to manually specify the left and right limits of the model cells used in the inversion model. This provides an alternative to using the distribution of the data points in the pseudosection or the limits of the survey lines in setting the edges of the model cell.



11.3.10 Type of cross-borehole model

There are two choices for the type of model you can use for the inversion of cross-borehole data. You can choose to use the Standard Model where the dimensions of the model blocks are the same as the spacing between the electrodes on the ground surface and in the boreholes. Alternatively, you can use a model with smaller blocks where the size of the blocks is half that of the Standard Model (Figure 11).

11.4 Model Sensitivity Options

This covers a few options related to the sensitivity values of the data set and model. Clicking this option will display the following list of sub-options.

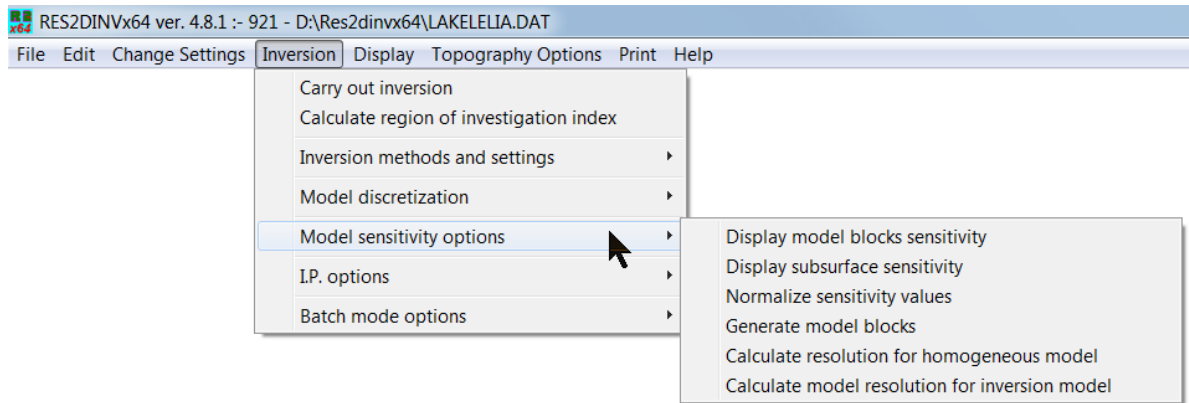

11.4.1 Display blocks sensitivity

This will show a plot of the sensitivity of the blocks used in the inversion model (Figure 35b). The sensitivity value is a measure of the amount of information about the resistivity of a model block contained in the measured data set. The higher the sensitivity value, the more reliable is the model resistivity value. In general, the blocks near the surface usually have higher sensitivity values because the sensitivity function has very large values near the electrodes. The blocks at the sides and bottom also have high sensitivity values due to the much larger size of these blocks that are extended to the edges of the finite-difference or finite-element mesh. If you had carried out an inversion of the data set before calling this option, the program will make use of the Jacobian matrix of the last iteration. Otherwise, it will calculate the Jacobian matrix for a homogenous earth model.

11.4.2 Display subsurface sensitivity

This shows a plot of the sensitivity of the subsurface for blocks of equal size (Figure 35a). This basically eliminates the effect of changes in the model block size so that it shows more clearly the change of the subsurface sensitivity with depth and location.

11.4.3 Normalize sensitivity values

By default, the calculated sensitivity values are normalized by dividing with the average sensitivity value. In this option, you can choose not to normalize the sensitivity values.

11.4.5 Generate model blocks

This option allocates the arrangement of the blocks in the model using the sensitivity values as a guide. Figure 35 shows the sensitivity values of the MIXEDWS.DAT data set using the default extended model (Figure 35a), and for the "Generate model blocks" option (Figure 35b). Note that the model created using the sensitivity values increases the width of the blocks near the sides in the deeper parts of the model section in order to increase the sensitivity values of the blocks. By default, the program uses a heuristic algorithm partly based on the position of the data points to generate the size and position of the model blocks. The "Generate model blocks" uses a more quantitative approach based on the sensitivity values of the model blocks. However, in practice, the simpler and faster heuristic algorithm gives reasonably good results for most data sets. Alternatively, you can use the 'extended model' option (section 11.3.4) to extend the model to the ends of the survey line, and later use the model sensitivity or resolution values to determine parts of the model which are well constrained by the data.

11.4.6 Calculate model resolution

The model resolution matrix is given by

$$\mathbf{R} = (\mathbf{J}^T \mathbf{J} + \lambda \mathbf{F})^{-1} \mathbf{J}^T \mathbf{J}. \quad (11.5)$$

The model resolution of the model blocks are given by the diagonal elements of this matrix. The model resolution matrix \mathbf{R} may be viewed as a filter through which the inversion method attempts to resolve the subsurface resistivity (Day-Lewis *et al.* 2004). In the ideal case with perfect resolution, the elements of the main diagonal (R_{ij}) are 1.0 while the off-diagonal elements are 0.0. In practice, the model resolution

values for most model blocks are much less than 1.0. The time taken to calculate the model resolution matrix is proportional to the cube of the number of model blocks, so it is probably only practical to carry out the calculations for models with less than about 30000 blocks. It is probably not practical to calculate the resolution values due to computer time and memory limitations for very large data sets and models. You can enable the calculation of the model resolution values using the following dialog box.

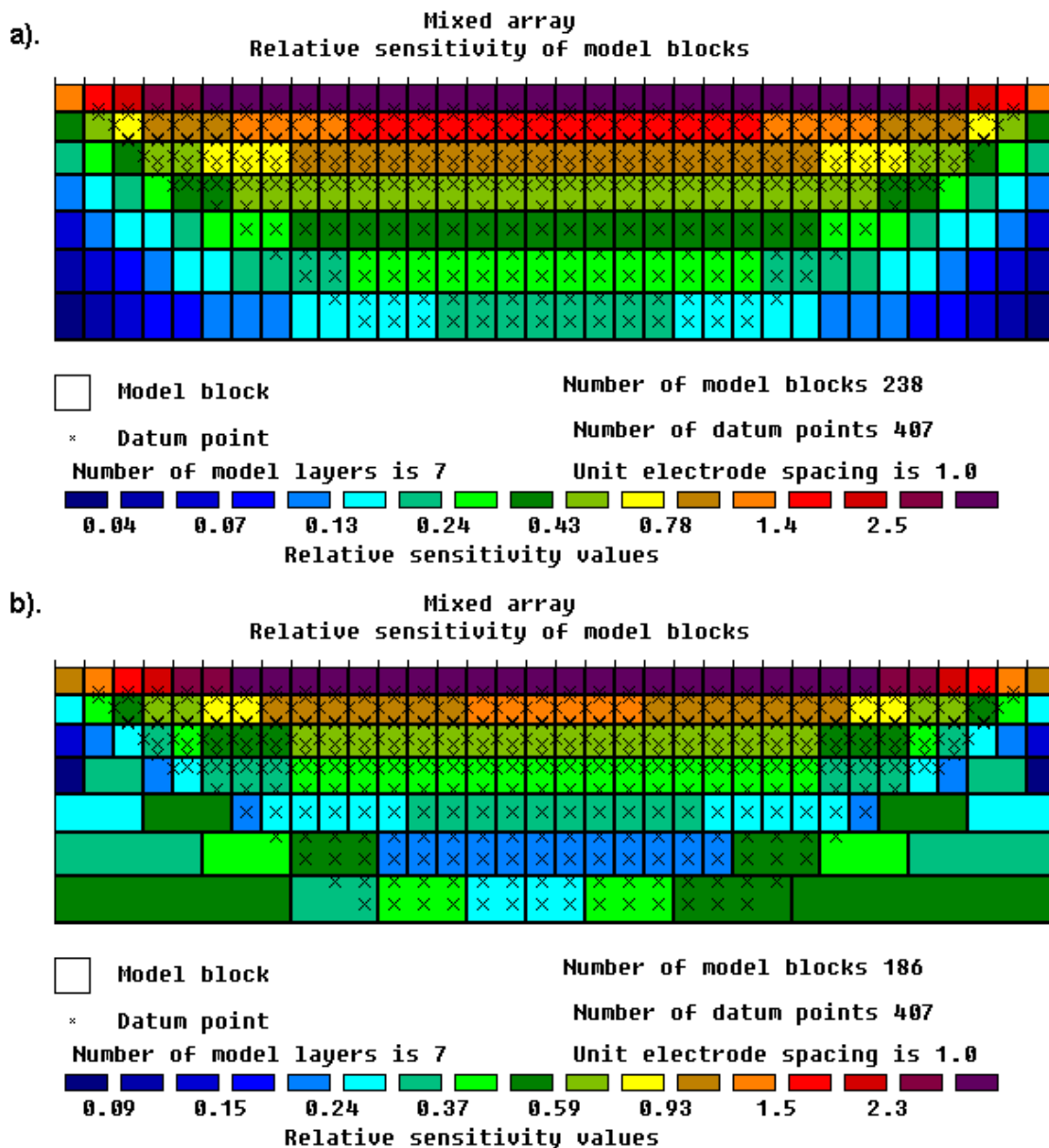
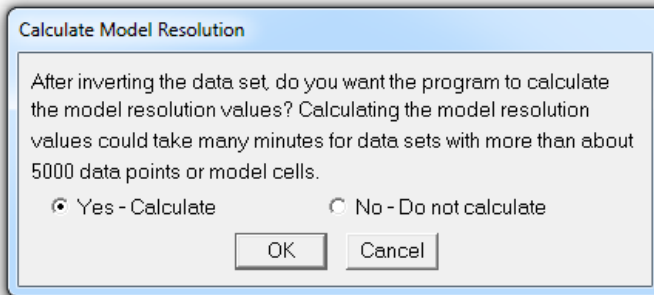
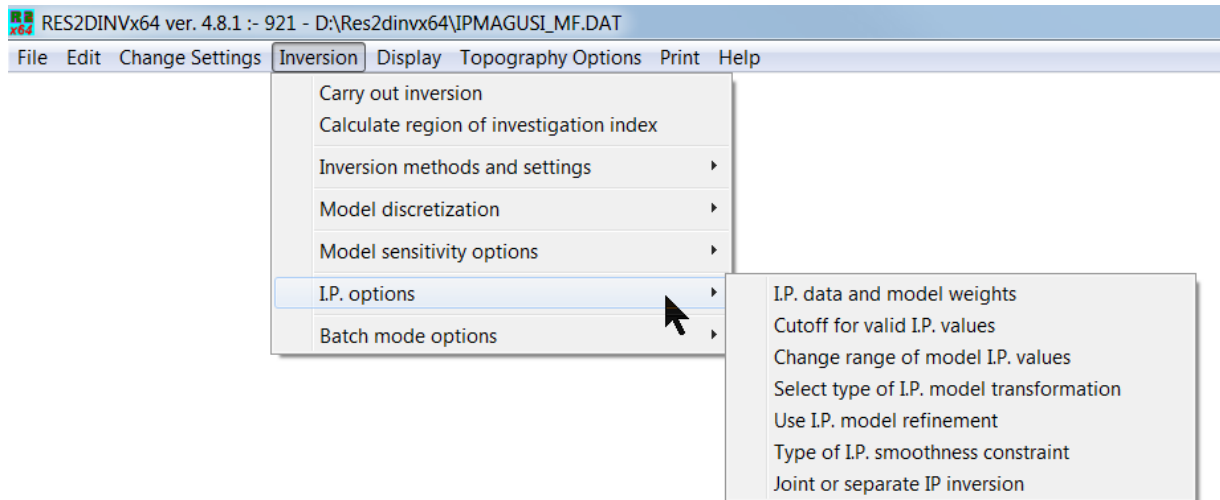

Figure 35. Two arrangements of model blocks using the extended model and sensitivity values methods. The arrangement of the model blocks used by the program for the inversion of the MIXEDWS.DAT data set using (a) the default extended model and (b) a model generated so that any single block does not have a relative sensitivity value that is too small.

11.5 I.P. Options

This covers a number of options for the inversion of data sets with I.P. measurements. Clicking this option will display the following list of menu sub-options.



11.5.1 I.P. data and model weights

This sub-option sets the weights given to the I.P. data and model in the joint resistivity-I.P. inversion method using the following dialog box.

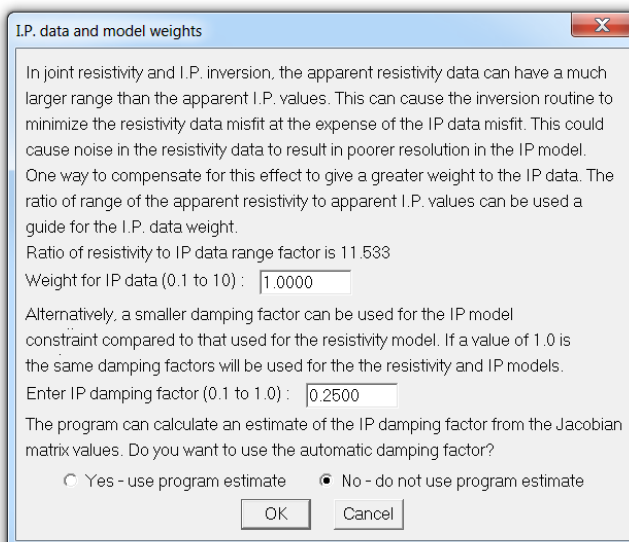

This program uses the complex resistivity method (Kenma *et al.* 2000) where the inversion of the apparent and I.P. data are inverted jointly. In most data sets, the data misfit for (the logarithm of the) apparent resistivity values have a much larger range than the apparent I.P. values. This causes the program to give a greater weight to reducing the data misfit for the apparent resistivity compared to the apparent I.P. The first parameter (weight for I.P. data) enables the user to compensate for this effect by giving a greater weight to the I.P. data misfit. The second parameter (I.P. damping factor) controls the amplitude of the change in the model I.P. values allowed after each iteration. A smaller I.P. damping factor can be used to allow a greater change in the I.P. model values (which is normally much smaller than the change in the model resistivity values in the joint inversion method). If a value of 1.0 is used, then the same damping factors will be used for both the resistivity and IP inversion routines. Normally a much smaller value of about 0.10 to 0.25 is used.

11.5.2 Cutoff for valid I.P. values

Many modern resistivity meter systems used in engineering and environmental surveys now have I.P. measurement capability as well. However, the I.P. data from most multi-electrode systems is probably of limited use for electrode spacings of more than a few meters. Most systems use a battery power source that cannot deliver enough current (usually less than 1 Amp) for reliable I.P. signals, so the I.P. data is often extremely noisy. Although in theory the magnitude of measured apparent I.P. values can

range up to 1000 mV/V, in practice natural I.P. effects produce much smaller values of usually less than 100 mV/V. This option sets an upper limit on acceptable apparent I.P. values above which the values are not used by the program to calculate the I.P. inversion model.

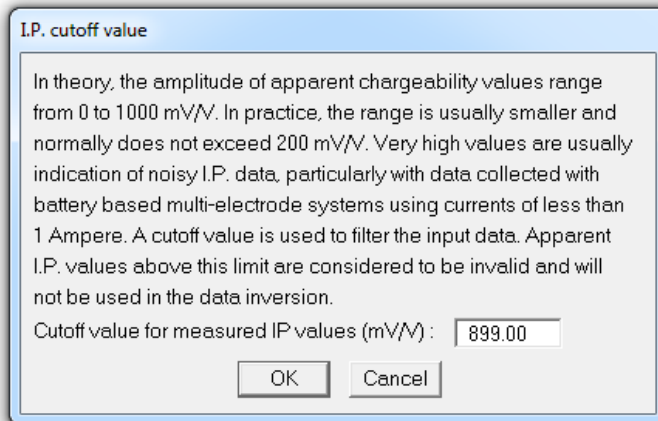

11.5.3 Change range of model I.P. values

This sets the limits of the model I.P. values that the inversion routine can use. The minimum model I.P. value is usually set at zero, although there have been reports of negative intrinsic I.P. values (Brandes and Acworth 2003). The upper limit for the maximum I.P. value for the inverse model can also be set in this option. Although in theory I.P. values can range up to 1000 mV/V, in practice it is unlikely to be more than a few hundred mV/V.

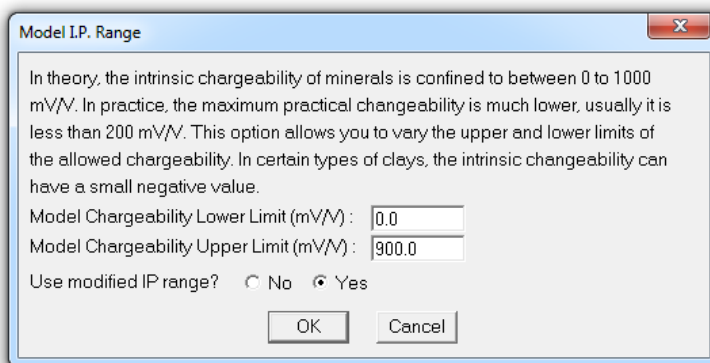

11.5.4 Select type of I.P. transformation

This option will bring up the following dialog box. The 'Square-root' or 'Range bound' is normally used to ensure the model I.P. values produced by the inversion program do not exceed the allowed limits. The 'Square-root' transformation ensures that the model I.P. is always positive but does not directly set an upper limit. The 'Range bound' method ensures that the model I.P. values are restricted to the range set in the previous option.

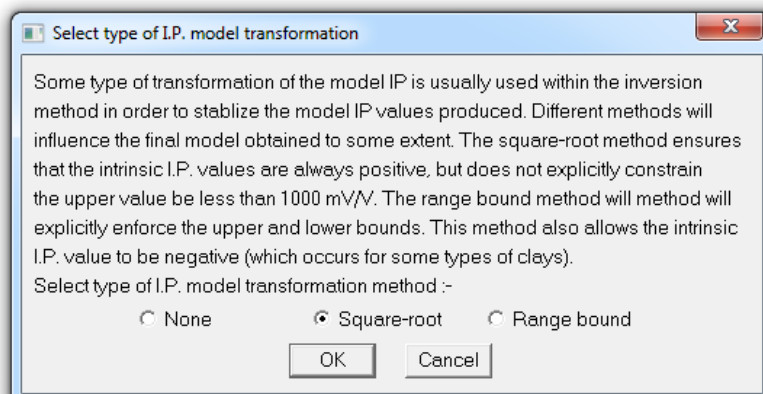

11.5.6 Use I.P. model refinement

This program uses the complex resistivity method for the inversion of I.P. data (Kenma *et al.* 2000). The effective conductivity is treated as a complex quantity with real and imaginary components. The complex conductivity is given by

$$\sigma = \sigma_{DC} - i m \sigma_{DC} \quad (11.6)$$

The DC conductivity σ_{DC} forms real part, while $m\sigma_{DC}$ forms the imaginary part. A complex potential is then calculated for this complex model.

$$\phi = \phi_r + i \phi_i \quad (11.7)$$

The complex potential has two components, ϕ_r and ϕ_i . The real (resistivity) and complex (I.P.) potentials are calculated simultaneously. The inversion method calculates the optimum resistivity and I.P. models simultaneously using the same least-equation (4.1). In many data sets, the resistivity data misfit has a much larger range than the I.P. data misfit. This causes the inversion routine to determine a more accurate resistivity model at the expense of the I.P. model that might show a much smaller change with each iteration. To overcome this problem, after calculating the optimum resistivity and I.P. model through a joint inversion, a separate inversion to minimize the I.P. data misfit alone by changing the model I.P. values only (and keeping the model resistivity values fixed) is commonly carried out in each iteration. This option allows the user to select the I.P. model refinement step via the following dialog box.

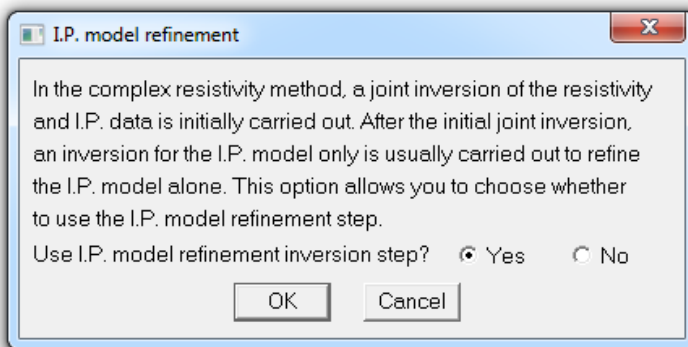

It is recommended that the I.P. refinement step to be used for most data sets.

11.5.7 Type of I.P. smoothness constraint

Normally the program uses the same smoothness constraint for the I.P. inversion as that used for the resistivity inversion. This option allows you to use a different smoothness constraint for the I.P. inversion. If the 'Robust' (L1-norm) method is used for the resistivity inversion, this option allows you to use the 'Smooth' (L2-norm) method for the I.P. inversion. Selecting the L2-norm constraint for the I.P. model might be useful for some cases as it has a much smaller range compared to the resistivity values. In theory, the I.P. model and (magnitude of the) data are limited to values of 0 to 1000 mV/V.

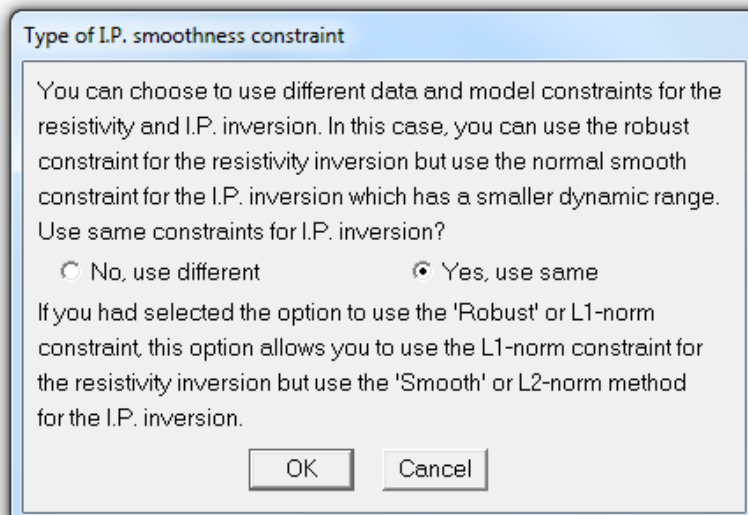

11.5.8 Joint or separate of I.P. inversion

The following dialog box is shown when this option is selected. In the complex resistivity method, the inversion model resistivity together with model I.P. values are simultaneously calculated. This option allows the user to fix the I.P. model when the resistivity model is calculated. It then only changes the model I.P. values during the I.P. model refinement step which is automatically enabled when the separate inversion option is selected..

In the resistivity inversion step, the I.P. data has a small effect on the resistivity model. However, the effect can be completely removed by choosing the option not to use the I.P. data in resistivity inversion if the separate inversion option is selected.

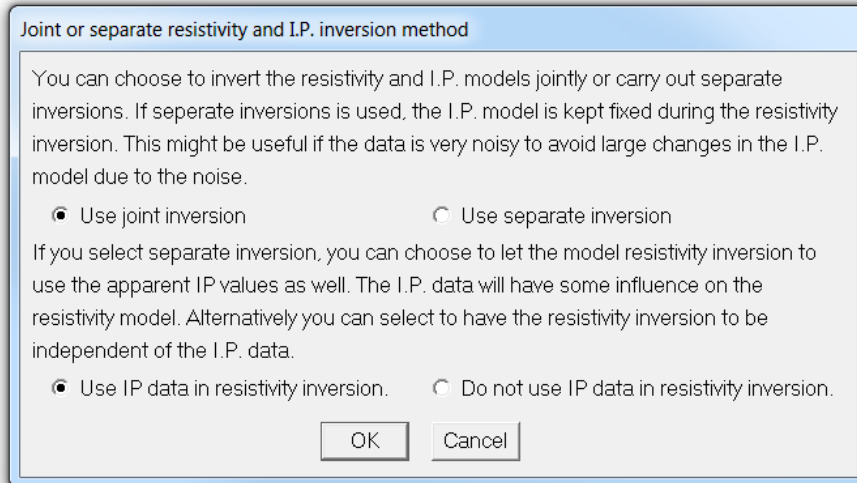

11.6 Batch mode options

There are two sub-options under this category.

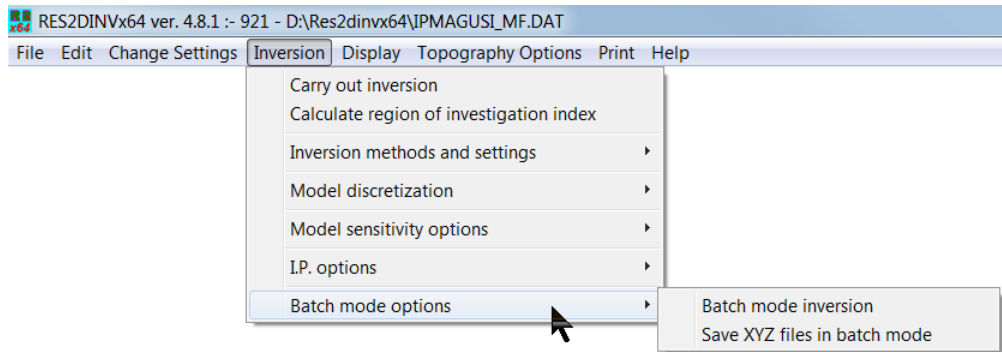

11.6.1 Batch mode inversion

In this option, you can invert a number of data sets automatically. The name of the input data files, and other information, is provided through a script file. It must be emphasized that before inverting the data sets, you should check the data for bad data points using the 'Edit - Exterminate bad data points' option (section 9.1) discussed earlier. When you select this option, the program will ask for a script file with a BTH extension. The file RESIS_IVP.BTH is an example script file. The format of the file is listed in Table 39. Since the IVP files are created by the RES2DINV program, it is not necessary for the user to deal with the details about the file format. To create them, you just need to click the appropriate inversion options within the RES2DINV program, and then select the "Save inversion parameters" option under the "Change Settings" menu to save the parameters into an IVP file. You can process up to 40 data files using a single batch script file.

11.6.2 Save XYZ files in batch mode

This option allows the user to automatically create the XYZ files containing the inversion model values after the inversion of each data file in the batch mode.

Table 39. Example script file for the batch mode inversion.

<i>RESIS_IVP.BTH file</i>	<i>Comments</i>
3	<i>Number of files to invert</i>
INVERSION PARAMETERS FILES USED	<i>Header</i>
DATA FILE 1	<i>Header for first file</i>
C:\RES2DINV\RATHCRO.DAT	<i>Name of first data file to invert</i>
C:\RES2DINV\RATHCRO_L2.INV	<i>Output file name with inversion results</i>
C:\RES2DINV\RES2DINV_L2.IVP	<i>File containing the inversion settings</i>
DATA FILE 2	<i>Header for second file</i>
C:\RES2DINV\RATHCRO.DAT	<i>Name of second data file to invert</i>
C:\RES2DINV\RATHCRO_L1.INV	<i>Output file with inversion results</i>
C:\RES2DINV\RES2DINV_L1.IVP	<i>File with different inversion settings</i>
DATA FILE 3	<i>Header for third file</i>
C:\RES2DINV\LANDFILL.DAT	<i>Third data file to invert</i>
C:\RES2DINV\LANDFILL_L2.INV	<i>Output file with inversion results</i>
C:\RES2DINV\RES2DINV_L2.IVP	<i>File containing the inversion settings</i>

11.7 Topography options

If there is significant topographical relief along the survey line, the effect of the topographical effects can be accounted for if the horizontal and vertical coordinates of a number of points along the survey line are known. When the program reads in a data file with topography data (please refer to section 7 for the data format), it will automatically select the finite-element method that incorporates the topography into the modelling mesh used. In this case, the topographic modelling will be automatically carried out by the program when you invert the data set. When you select the “Topography Option” menu, the following submenu will be displayed.

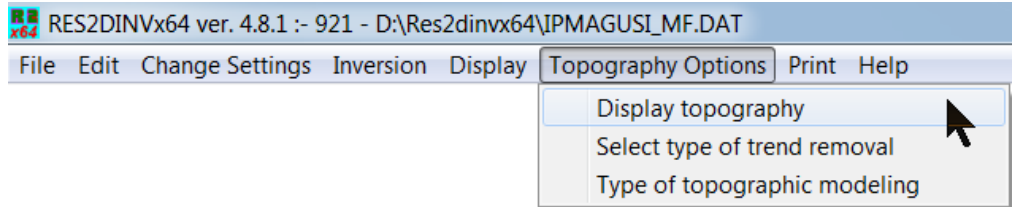

11.7.1 Display topography

This option simply plots the topography, such as in Figure 36.

11.7.2 Select type of trend removal

You can choose to remove the average elevation, a least-squares linear trend, or a straight line joining the first and last topography data points. If the ground surface along the survey line is generally flat except for a few points, use the option to subtract a constant value from the heights of the electrodes locations. If the survey points are on a slope, choose either a least-squares or an end-to-end straight line for the linear trend. Figure 36 shows an example with topography where the end-to-end straight line trend was removed.

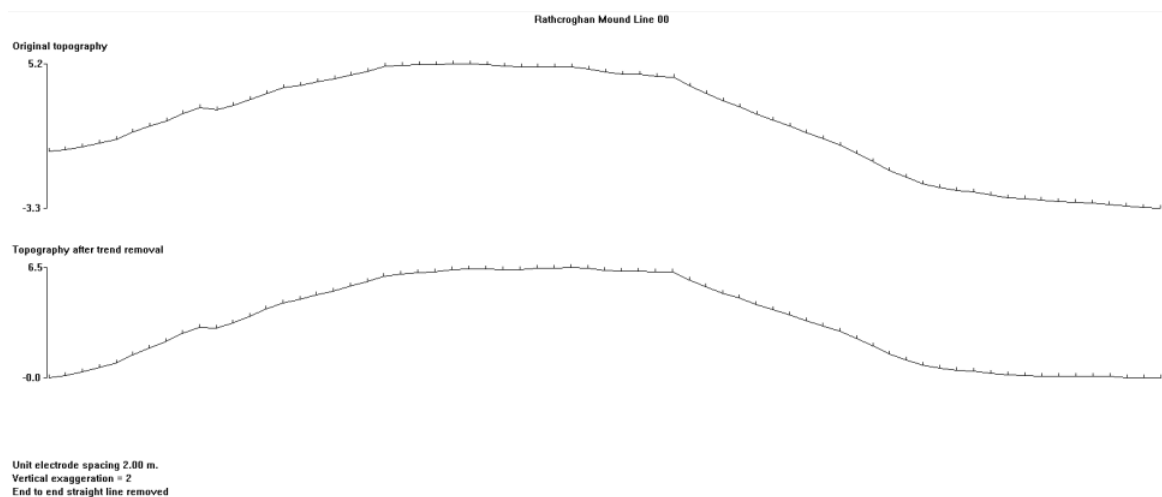
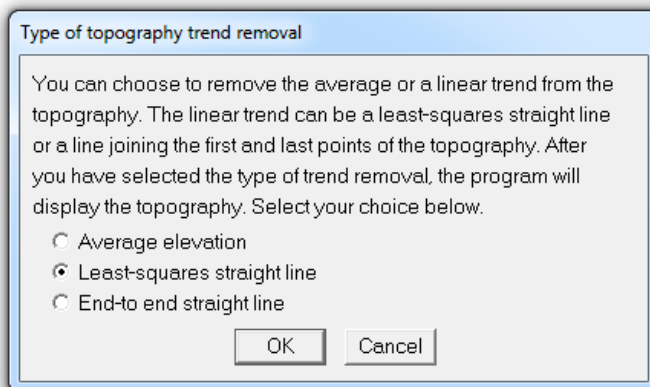
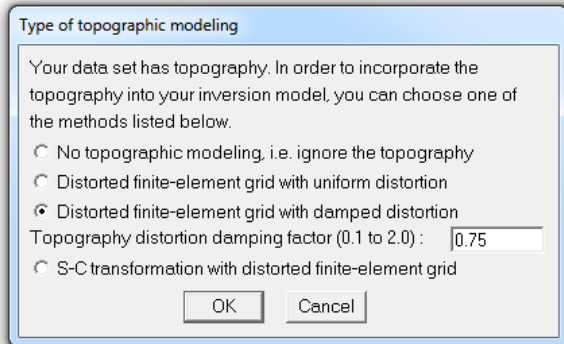

Figure 36. Topography linear trend removal for the Rathcroghan mound data set.

11.7.3 Type of topographic modeling

Selecting this option will show the following dialog box where you can choose three different topographic modeling methods.



Distorted finite-element grid with uniform distortion : This method, and the next two methods, use a distorted finite-element grid such that the surface nodes of the mesh match the actual topography. This gives more accurate results than the older method of using the correction factors for a homogeneous earth model calculated with the finite-element method (Fox *et al.* 1980) which can cause distortions in cases where large resistivity variations occur near the surface (Tong and Yang 1990; Loke 2000). In this particular option, the nodes below the surface (and thus also the model layers) are shifted to the same extent as the surface nodes.

Distorted finite-element grid with damped distortion : In this option, the subsurface nodes are shifted to a lesser extent compared with the surface nodes, i.e. the effect of the topography is “damped” with depth. This option is probably a reasonable choice if the curvature of the topography is less than the depth of the deepest model layer. A damping factor that controls the degree of damping with depth (Figure 38) can be modified by the user.

S-C transformation with distorted finite-element grid : This method uses the Schwarz-Christoffel transformation method to calculate the distortion in the subsurface layers. It is probably the best method that produces a more ‘natural’ looking model section in cases with a comparatively large topography curvature. In such cases, the damped topography approach might produce unusually thick model layers under areas where the topography curves upwards. In some unusual cases where the topography has very sharp acute peaks or valleys and sparse topography data points, the Schwarz-Christoffel transformation method might not work. If this happens, add a few extra topography data points near the places with a sharp curvature in the topography.

Figure 37 shows an example of an inversion model for the Rathcroghan Mound (Waddell and Barton 1995) data set that has topography from Ireland. The burial chamber is the prominent high resistivity region a few meters below the surface below the 20 meters mark. The L1-norm inversion method was used to sharpen the burial chamber and the surrounding soil. A unit electrode spacing of 2 meters was used during the survey, but the inversion model uses model blocks of 1 meter width due to significant lateral variations near the surface.

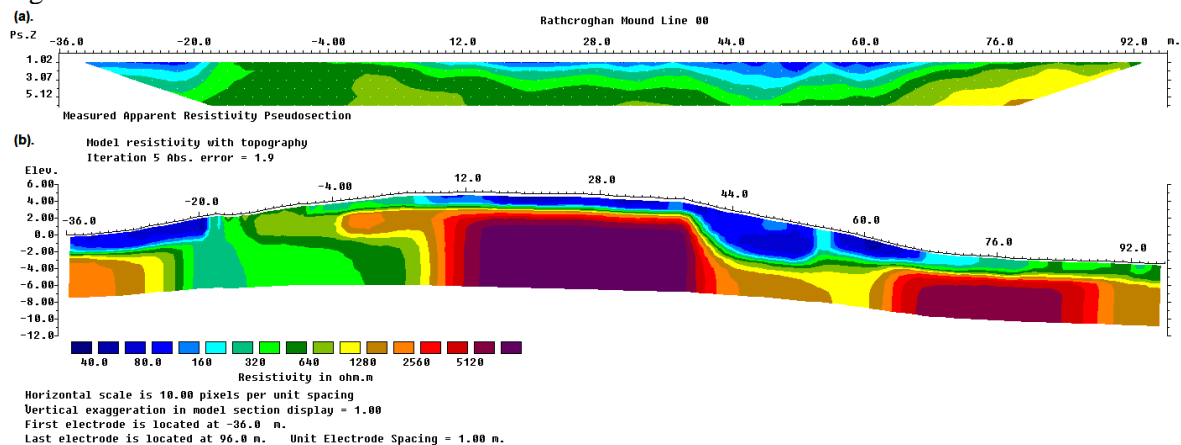
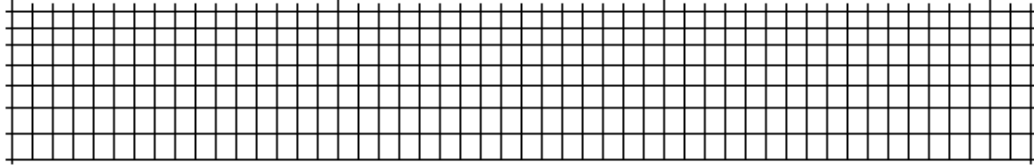
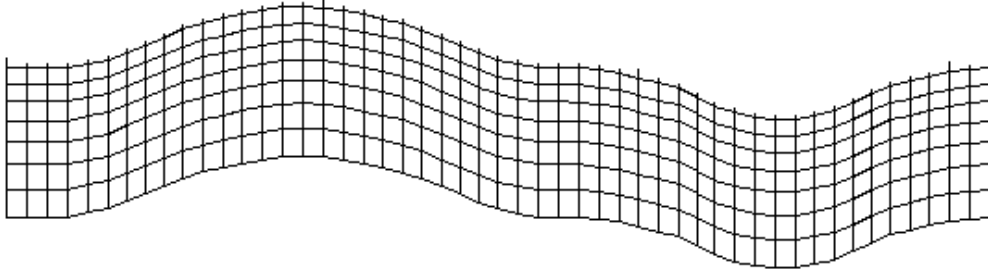

Figure 37. Example of the model for the Rathcroghan Mound data set. (a) Measured apparent resistivity pseudosection. (b) Inverse model section with topography.

a). Arrangement of model blocks without topography



b). Arrangement of model blocks with a uniformly distorted grid



c). Arrangement of model blocks with a moderately damped distorted grid

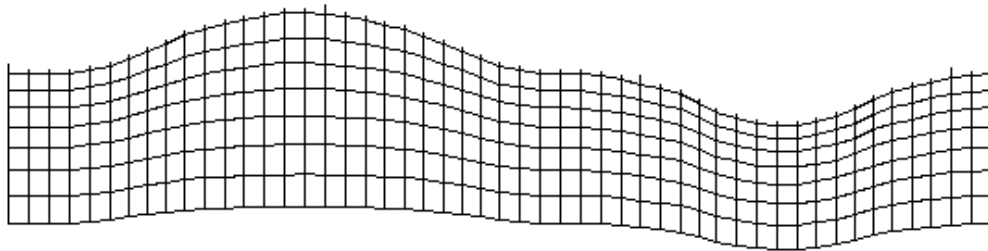

d). Arrangement of model blocks with a highly damped distorted grid

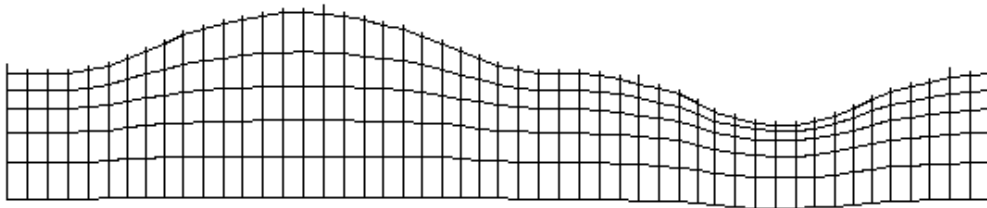

e). Arrangement of model blocks with the inverse Schwartz-Christoffel transformation

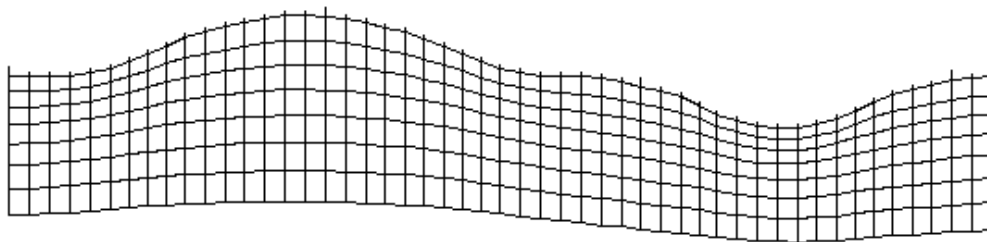
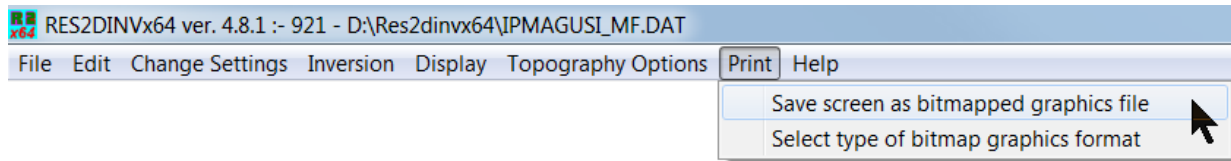

Figure 38. Different methods to incorporate topography into a 2-D inversion model. (a) Schematic diagram of a typical 2-D inversion model with no topography. Model mesh discretization with a distorted grid to match the actual topography where (b) the subsurface nodes are shifted vertically by the same amount as the surface nodes, (c) the shift in the subsurface nodes are gradually reduced with depth or (d) rapidly reduced with depth, and (e) the model obtained with the inverse Schwartz-Christoffel transformation method.

12 Print menu

Clicking this menu will display the following option.



Print - Save screen as bitmapped graphics file : This option makes a screen dump of the sections drawn on the screen.

Select type of bitmap graphics format : This option selects the type of bitmap graphics format to use for the screen dump. The options are shown below.

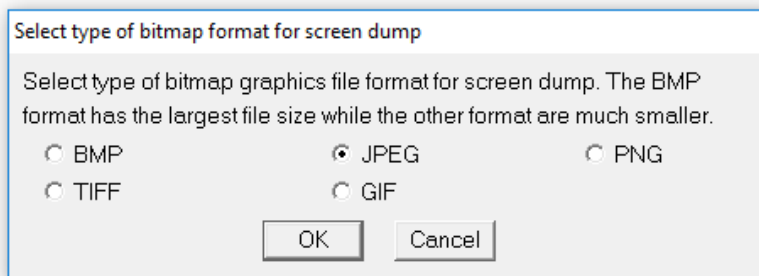

13 Help menu

Clicking the Help menu option will display the following list of sub-options.

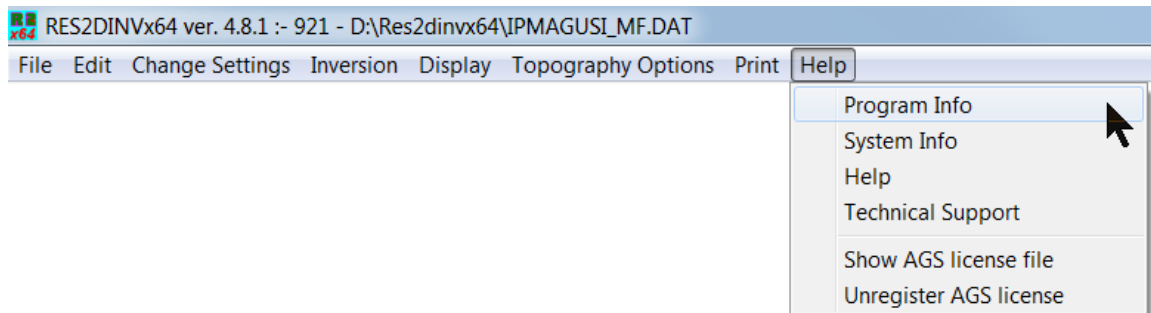

Program info : This will display the copyright notice and website address for downloading program updates.

System info : This will display the computer resources and program license number.

Help : This will launch the help file for the program, if the Res2dinv.chm file is in the same folder as the Res2dinvx64.exe file.

Technical support : This will display the email address for technical support as well as the customer information required.

Show AGS license file : This shows the contents of the file in the computer installed by the AGS online digital copy protection system.

Unregister AGS license : This removes the AGS license from the computer so that it can be installed on another computer.

14 Displaying and exporting inversion model results

Selecting the 'Display' menu option will create a new window with a number of options to read the INV files produced from the inversion of the data sets, and to display and export the information to other programs.

14.1 File menu options

Clicking the 'File' menu will display the following list of sub-options.

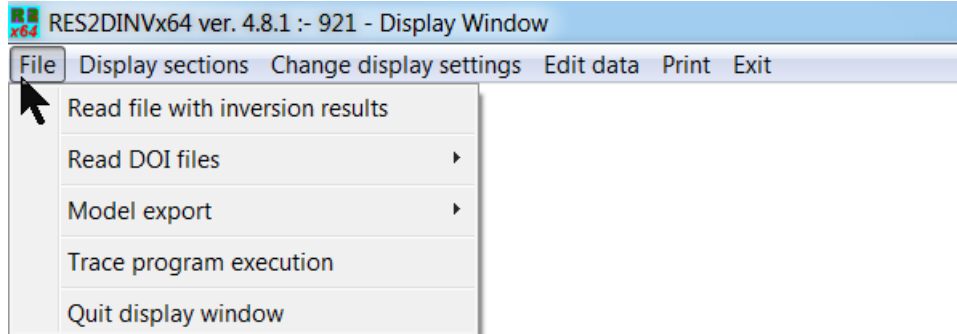

14.1.1 Read file with inversion results

This option is used to read in a file with an INV extension produced by the Res2dinvx64 program that contains the inversion results.

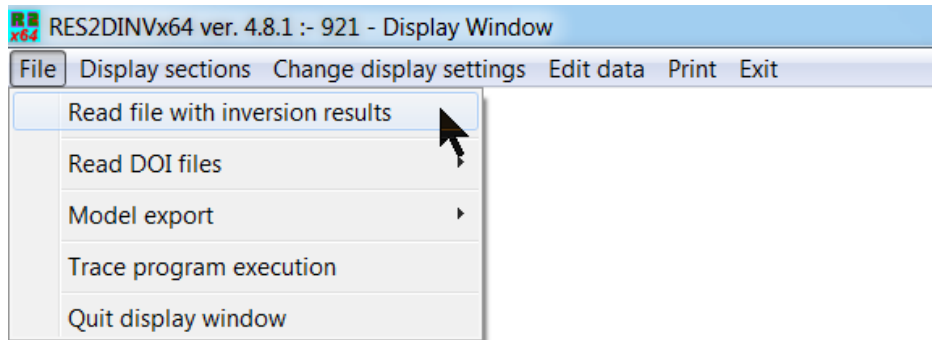

14.1.2 Read DOI pair of inversion files

This option reads in the TXT file that contains the names of the pair of INV files created when the option to 'Calculate region of investigation index' (section 11.1.2) was earlier selected. This will automatically read in the two files and calculate the DOI values. This should only be used if the inversion was carried out on the same computer.

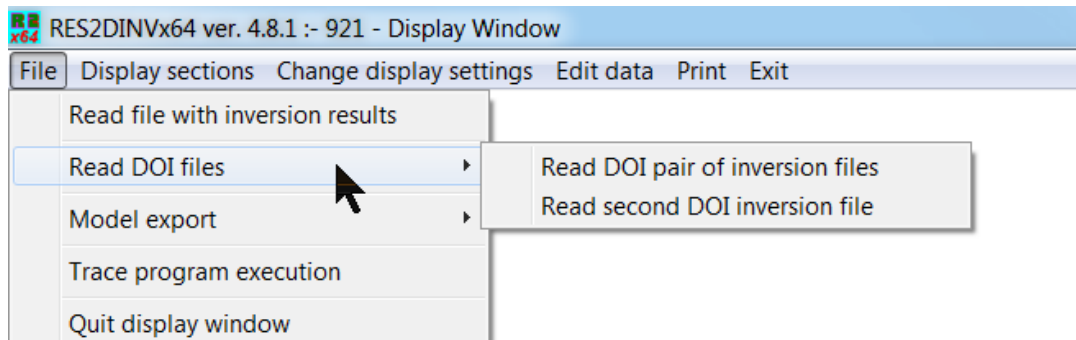

14.1.3 Read second DOI inversion file

This option should be used if the INV files from the 'Calculate region of investigation index' are copied from a different computer. In this case, the folders listed in the TXT file might not be valid. To calculate the DOI values, the two files must be read in separately. Read the first file using the 'Read file with inversion results' option listed above. Next use this 'Read second DOI inversion file' option to read in the second INV file.

14.1.4 Model export

Selecting this option will display the following list of sub-options to export the inversion model values to different file formats.

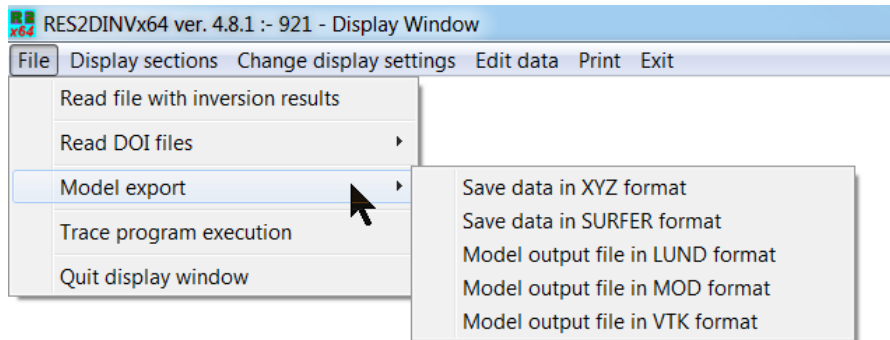

Save data in XYZ format - This saves the data and model values into a text based XYZ type of format used by many contouring programs, such as by Geosoft. These are separate programs sold by GEOSOFT Inc. and other companies that enable you to use more sophisticated contouring techniques than those used by the RES2DINV program.

Save data in Surfer format - This option allows the user to save the apparent resistivity pseudosections and model sections in the format used by the SURFER graphics 2-D plotting program by Golden Software. A description of the steps involved is described in Appendix E.

Model output in Lund format - This is a data format used by the LUND Imaging System produced by ABEM. You can save the model resistivity values in the .RHO and .RMS files used by the MODSEC program.

Model output in MOD format - This saves the inverse model into the format used by the RES2DMOD forward modelling program.

Model output in VTK format - This saves the inverse model into the VTK format used by the free Paraview 2-D and 3-D graphics plotting program. Global coordinates, if present, are also stored in the vtk files so that models from different lines have the same coordinate system.

14.1.5 Trace program execution

When this option is enabled, the program will dump information into a R2DTRACEX64.TXT file during the inversion process. This is mainly used to trace problems in the program if it is unable to read or invert a data file. The file will be saved in the 'temp_buffer_2di' folder in the buffer drive.

14.2 Display sections menu options

This covers several options to display the model sections.

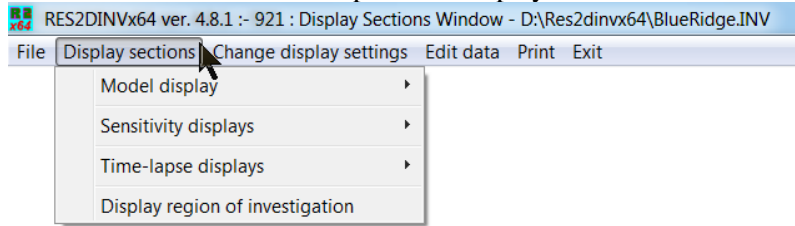

14.2.1 Display data and model sections

Clicking this option will bring up the following list.

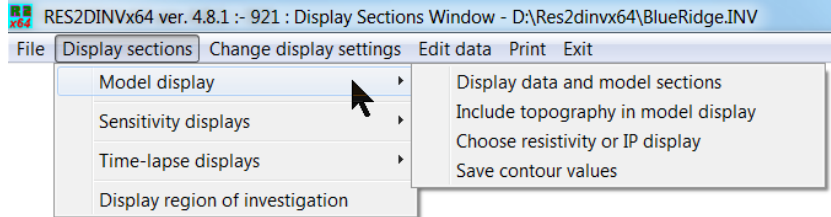

Display data and model sections - Select this option to plot the model and apparent resistivity sections on the screen. After selecting this option, you will be prompted for the iteration number to use, and the type of contour intervals. The following dialog box will be shown for resistivity data where all the values are positive.

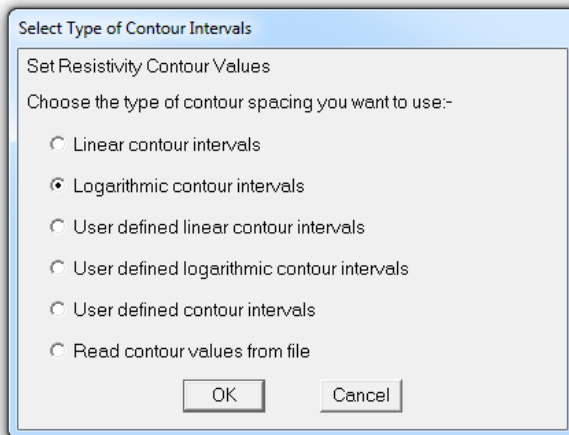

The 'Linear contour intervals' option will automatically set the contour intervals that are linearly spaced out. This is usually not the best option for resistivity data if it has a large range but is more suitable for I.P. data that have a more limited range. The 'Logarithmic contour intervals' will space out the contours on a logarithmic scale and should normally be used for resistivity sections. The 'User defined linear contour intervals' option will bring up the following dialog box.

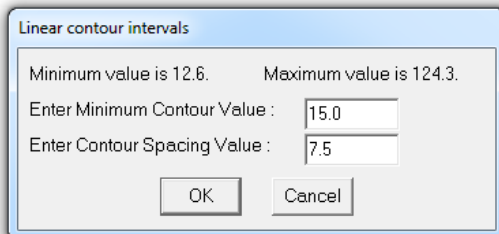

You should select the initial contour value and spacing such that it covers the range of resistivity values. Choosing the 'User defined logarithmic contour intervals' option will bring up the following dialog box.

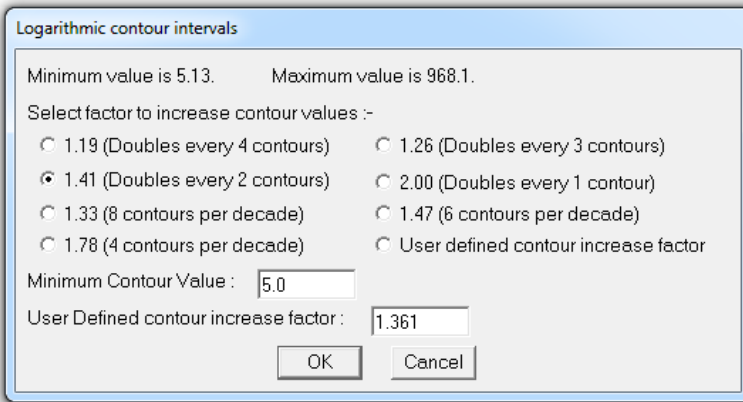

There are two sets of the automatic factors to increase the contour values starting from the minimum value. The first set doubles the contour values after every 1 to 4 contours. The second set increases the contour value by a factor of ten after every 4 to 8 contours. A user defined factor to increase the contour value is also available. Selecting the 'User defined contour intervals' option will bring up the following dialog box.

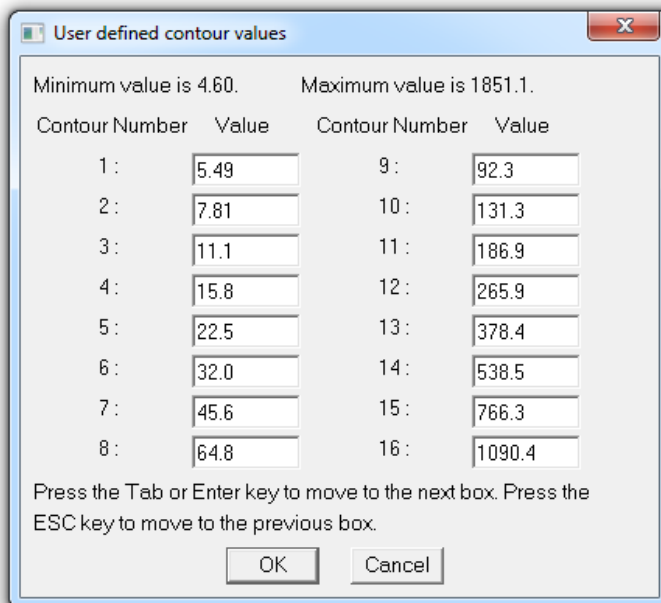

A set of default contour values using a logarithmic or linear scale will be displayed. The user can change the contour values manually. The last option 'Read contour values from file' enables the user to reuse contour values that was saved earlier into a file using the 'Save contour values' menu option.

Include topography in model display - For inversion results where topographic modeling were earlier carried out, you can incorporate the topography into the model section by calculating that the true depth and location of the model blocks below the surface. Figure 37 shows an example of a model section with the topography. After the section is displayed, you can display the results for the next iteration by pressing the PgDn key. Similarly, pressing the PgUp key will display the results for the previous iteration.

Choose resistivity or I.P. display - If the data set has I.P. data as well, this option allows you to choose to display the resistivity or I.P. sections. You can also display both the resistivity and IP model sections at the same time.

Save contour values - This option saves the values used to draw the contours in the pseudo and model sections into a file.

14.2.2 Sensitivity displays

This set of options display the model sections with the sensitivity or resolution values.

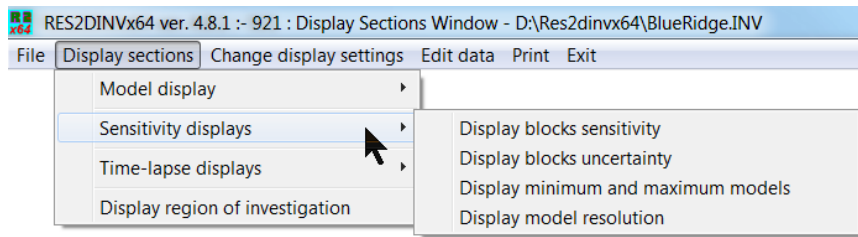

Display blocks sensitivity - This displays a section with the sensitivity value associated with each model block. This actually gives the integrated sensitivity value associated with each model block as given by the following equation.

$$S_i = \frac{1}{m} \sum_{j=1}^m |J_{ij}| \quad (14.1)$$

It sums up the Jacobian matrix values associated with the model block for all the data points. It is a very crude measure of the information the data set has on the resistivity value of a model block. A better measure is the model resolution value.

Display blocks uncertainty, minimum and maximum models - This displays an estimate of the uncertainty in the model resistivity values, and the lower and upper limits of the resistivity values based on the estimated uncertainty. If the model resolution was calculated, the uncertainty value is calculated from the diagonal elements of the $(\mathbf{J}^T \mathbf{J} + \lambda \mathbf{F})^{-1}$ matrix. If the model resolution was not calculated, an approximation of the uncertainty is used. The maximum and minimum sections are calculated from the inversion model values and the estimated uncertainty in the model values.

Display model resolution - If the option to calculate the model resolution values was selected (section 11.4.6), the model resolution values will be saved in the INV file. This option displays the saved model resolution values in the form of a section. Selecting this option will display the following dialog box.

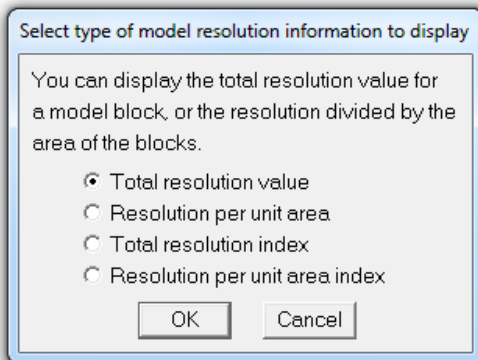

The first option displays the raw model resolution values, while the second option displays the model resolution normalized by the cross-sectional area of the model block. Other things being equal, a model block with a larger area will have a larger resolution value by virtue of its size. The thickness of the model layers increases with depth, and the blocks at the sides extend laterally to the edges of the finite-element/finite-difference mesh. Thus, the blocks at the sides have a much larger area than neighboring blocks in the interior of the model. As an example, Figure 39 shows the inversion model for the LANDFILL.DAT data set together with the model resolution sections. Note the model resolution values (Figure 39c) show a slight increase towards the sides and bottom of the section particularly at the bottom-left and bottom-right corners which might be misleading. This is due to the large sizes of the model blocks at the sides and bottom. The model resolution normalized by the area of the blocks (Figure 39d) avoids this artifact. Some authors recommend using a value of 0.05 (i.e. 5%) as the cutoff value to judge whether a region has significant resolution. Using a value of 0.05 as the cutoff point for the model resolution values might be arbitrary as it does not take into account the model discretization used. If a finer model discretization (with more model cells) is used, we would expect on the average the model resolution for a cell at the same location will be reduced since the cell size is smaller. Theoretically the sum of the elements in a column of the model resolution matrix is equals to 1.0. The average value of the array elements in the column would then be equals to $1.0/m$, where m is the number of model cells. A

more useful measure to judge whether a model cell is resolved is the ratio the cell resolution value to this average value. The third and fourth option displays the model resolution multiplied by the number of model cells. It removes the effect of the model discretization used (Loke 2018). The model resolution index section after normalization by the model block area is shown in Figure 39e. A reasonable model resolution index cutoff value would be about 5 to 10.

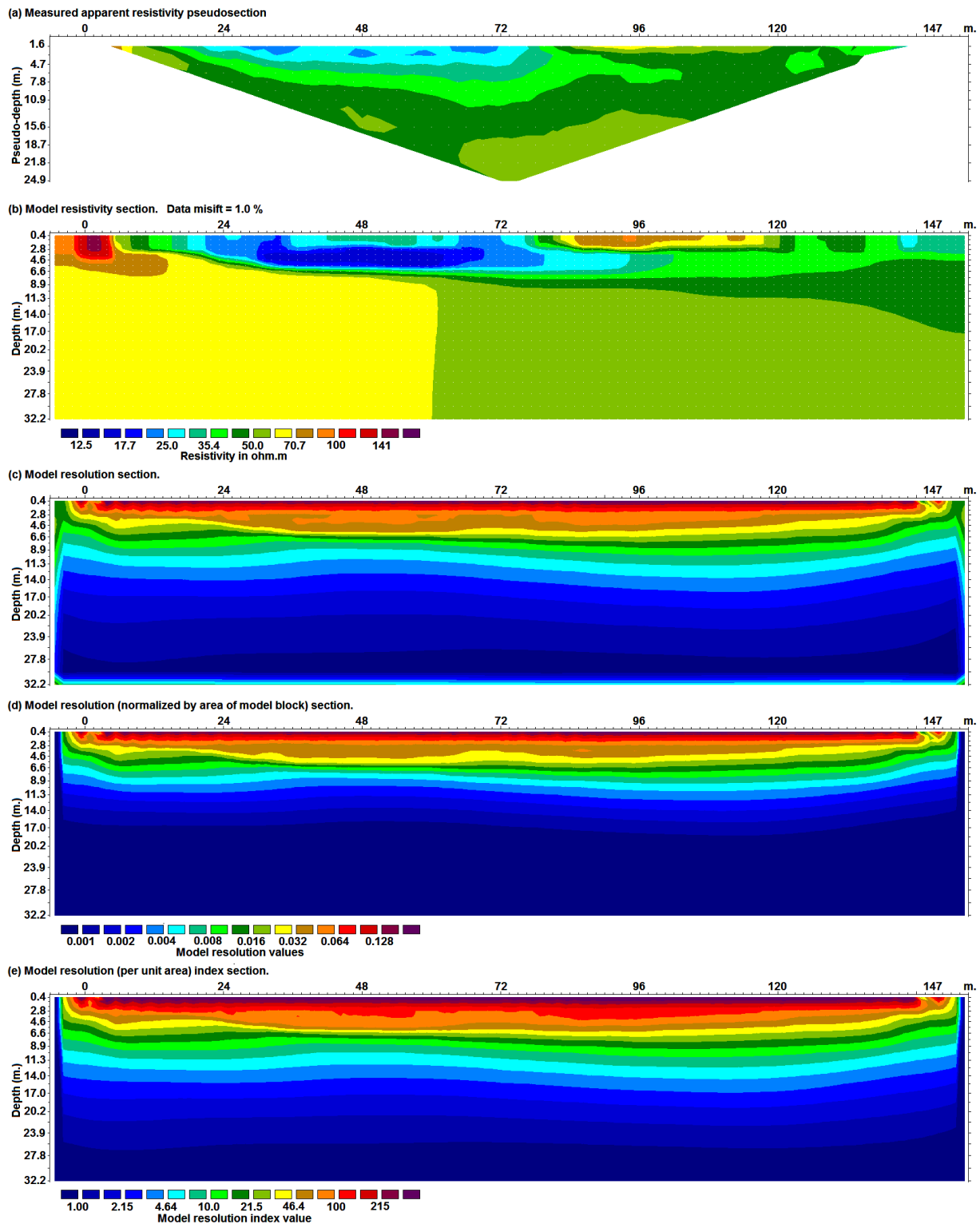
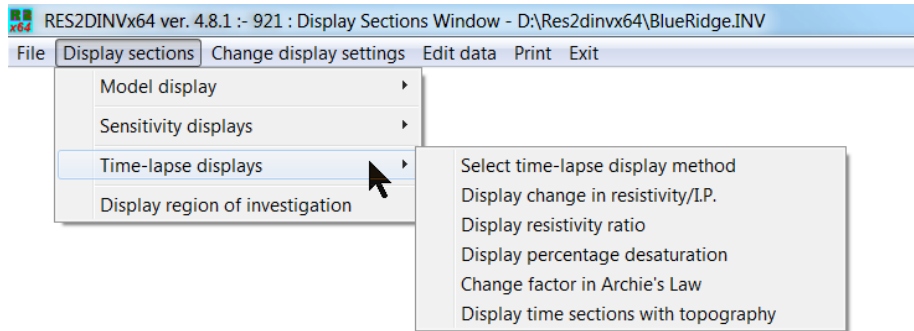

Figure 39. Model resolution sections for the LANDFIL.DAT data set. (a) Apparent resistivity pseudosection. (b) Inversion model section. (c) Model resolution section. (d) The model resolution normalized by the cross-section area of the model block. (e) The model resolution index (after normalization by model block area) section.

14.2.3 Time-lapse displays

This shows the inversion results for time-lapse data sets. Time-lapse files have the resistivity values for two or more inverse models. The following option displays the change in the model resistivity values between the initial model and a later time model.



Select time-lapse display method – You can display the change in the resistivity of a later-time model compared to the first-time model or compared to the preceding-time model. For example, if there are four time-series models, you can display the change in the fourth time-series model compared to the first time-series model or compared to the third time-series model.

Display change in resistivity/I.P. - This option will display the change in the model resistivity obtained from the inversion of a later time data set compared with the reference model from the inversion of the first data set. After displaying the sections with the percentage change in the model resistivity values, you can change the time-lapse data set selected by using the 'Home' and 'End' keys. By default, the results for the last time-lapse data set will be shown. You can show the results of an earlier data set by pressing the 'Home' key. As an example of a field experiment of time-lapse measurements, Figure 40 shows the results from a test on the flow of water through the unsaturated zone conducted in Birmingham (Barker and Moore 1998). Forty thousand liters of water was poured on the ground surface near the 24 meters mark along the survey line over a period of 10 hours. The initial data set collected before the water irrigation began together with the corresponding inverse model are shown in Figure 40a and Figure 40b. The subsurface consisting of sand and gravel is highly inhomogeneous. As a comparison, Figure 40c and Figure 40d shows the data collected and inversion model after the irrigation of the ground surface was completed. The distribution of the water is not very clear from a direct comparison of the inversion models alone. The water distribution is more easily determined from a plot of the percentage change in the subsurface resistivity in the inversion models for the data sets taken at different times (Figure 41) when compared with the initial data set model. The data set collected at 10 hours after the irrigation began shows a significant reduction in the resistivity (of more than 60 percent) near the ground surface in the vicinity of the 24 meters mark where the near-surface low resistivity zone has reached its maximum extent and amplitude (Figure 41a). Six hours after the irrigation was stopped, the low resistivity plume has spread downwards and slightly outwards due to infiltration of the water through the unsaturated zone into the water table (that is at a depth of about 3 meters). There causes a decrease in the maximum percentage reduction in the resistivity values near the surface (Figure 41b).

Display resistivity ratio - This option will display the ratio of resistivities of the later time model compared with the reference model.

Display percentage desaturation - Archie's Law that gives the relationship between the resistivity of a porous rock and the fluid saturation factor is applicable for certain types of rocks and sediments, particularly those that have low clay content. In the case, the electrical conduction is assumed to be through the fluids filling the pores of the rock. Archie's Law is given by

$$\rho = a\rho_w\phi^{-m} \quad (14.2)$$

where ρ is the rock resistivity, ρ_w is fluid resistivity, ϕ is the fraction of the rock filled with the fluid, while a and m are two empirical parameters (Keller and Frischknecht 1966). For most rocks, a is about 1 while m is about 2. Under certain special conditions, the above equation can be used to determine the change in the fluid saturation or fluid resistivity with time. If initially the subsurface material is saturated with water, and the change in the resistivity is caused by withdrawal of water (i.e. a reduction in the fraction per unit volume of the rock which is filled with water), the desaturation factor (Keller and Frischknecht 1966) can be calculated from the change in the subsurface resistivity. To calculate the desaturation factor, the value of the m parameter in Archie's Law is needed. By default, it is set to 2.0 but this value can be changed by the user. On the other extreme, consider a case where the fluid saturation

factor does not change but the resistivity of the fluid changes (for example in tracer experiments with a conductive salt below the water table). The ratio of the resistivity of the fluid at the later time to the initial resistivity can be calculated directly from the model resistivities. It must be emphasized that the above two situations are ideal cases. The results are only valid if Archie's Law holds for the subsurface medium. In many cases, the relationship between the medium resistivity and water content is much more complicated (Olivar *et al.* 1990).

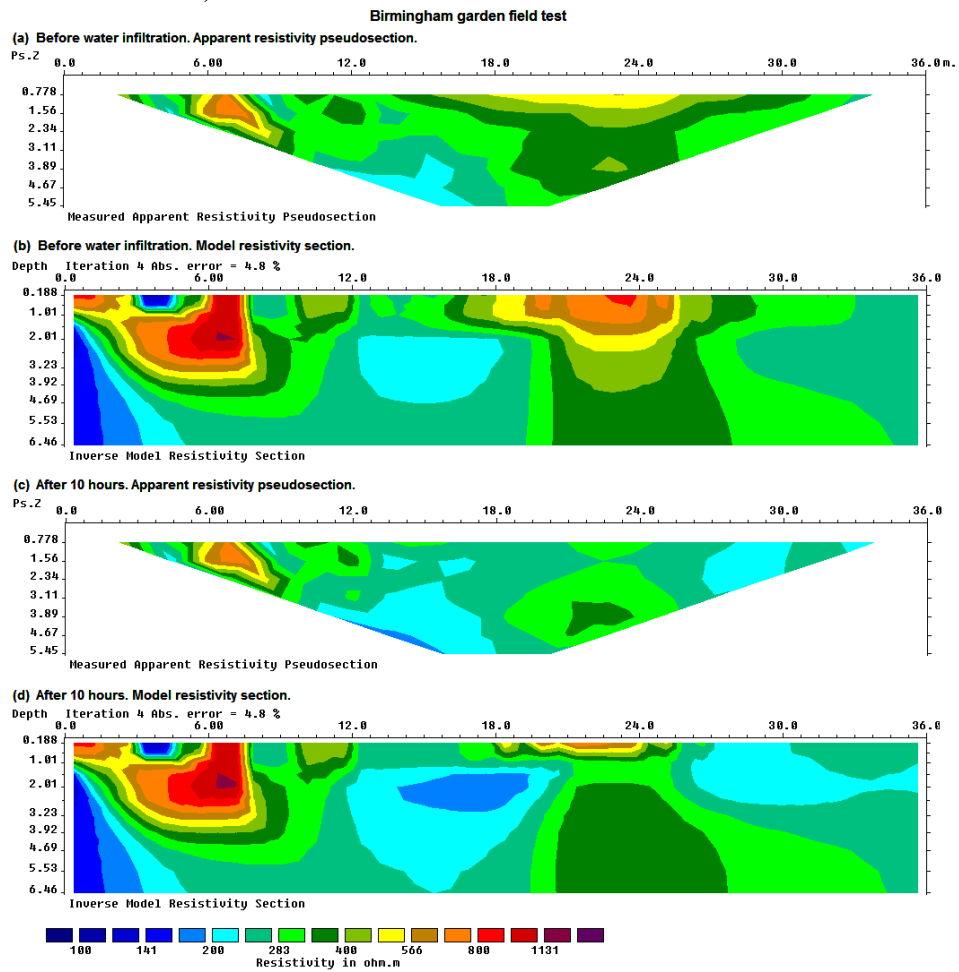

Figure 40. Apparent resistivity and inversion model sections from the Birmingham time-lapse experiment. (a) The apparent resistivity and (b) inversion model sections from the survey conducted at the beginning of the Birmingham infiltration study. The data and model after 10 hours of irrigation are shown in (c) and (d).

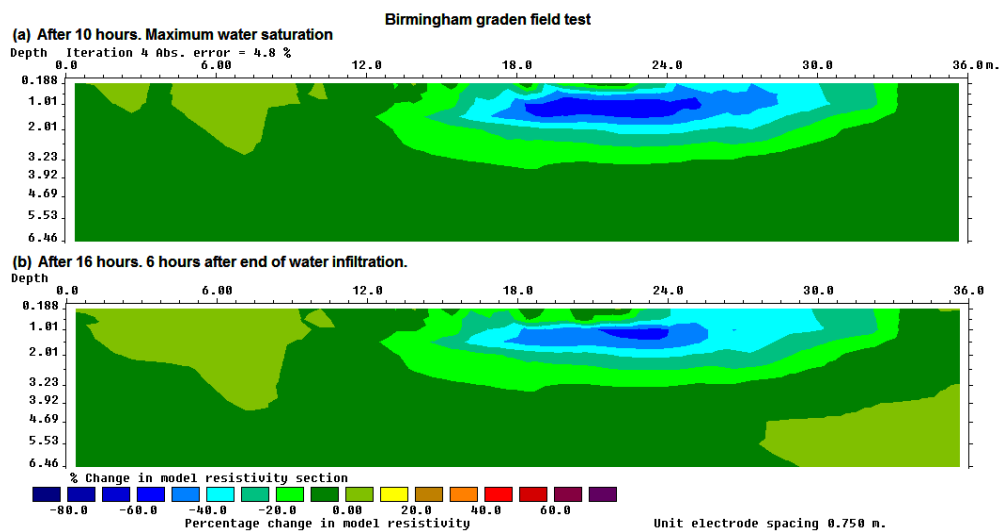

Figure 41. Sections showing the change in the subsurface resistivity values with time obtained from the inversion of the data sets collected during the infiltration and recovery phases of the study.

Change factor in Archie's Law - This option allows the user to change the exponent m in equation (14.1) used to calculate the desaturation value.

Display time sections with topography - This option display the sections with the percentage change or resistivity ratio with topography included.

14.2.4 Display region of investigation

This display the depth of investigation (DOI) section if it was calculated. On selecting this option, the following dialog box will be shown.

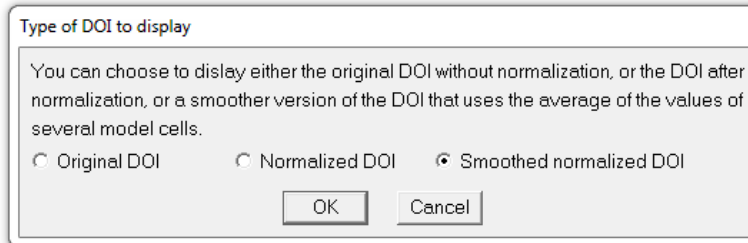

The different types of DOI are described in Appendix F. After you select the appropriate choice, you will need to select the type of contour values to use for the DOI and model resistivity sections. An example of a DOI section plot is shown in Figure 51 in Appendix F.

14.3 Change display settings

This cover a number of parameters that control the display of the sections as listed in the following menu.

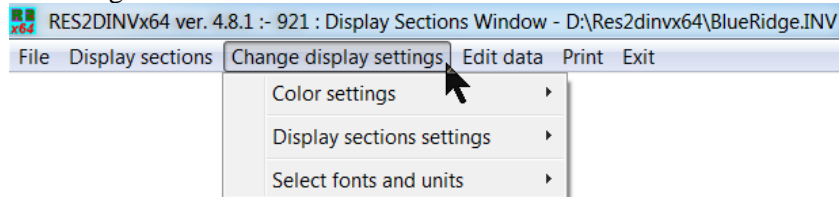

14.3.1 Color settings

This cover a number of options to change the colors used in drawing the sections. The program uses 17 colors in the contour scale used in drawing the sections. You can adjust the colors using the options in the following menu list.

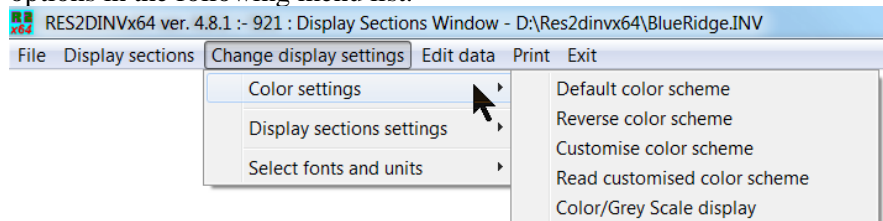

Default color scheme - This will reset the color scheme used for coloring the sections to a default system used by the program.

Reverse color scheme - The default color scheme uses blue for low resistivity values, and red for high values. This enables the user to reverse the colors used.

Customize color scheme - This option can be used to manually change the colors used. After changing the values, the color scheme can be saved into a file so that it can be reused.

Read customize color scheme - You can change the color scheme to a set of customized colors that was earlier saved in a file.

Color/Grey Scale display - By default, the program will display the pseudosections and model section in color. This option allows you to display the sections using a grey scale, possibly for making printouts on normal laser printers. Different shades of grey, ranging from pure white to pure black, are used.

14.3.2 Display sections settings

This set of options change the number of sections displayed, the horizontal and vertical scales.

The various options are listed in the following menu.

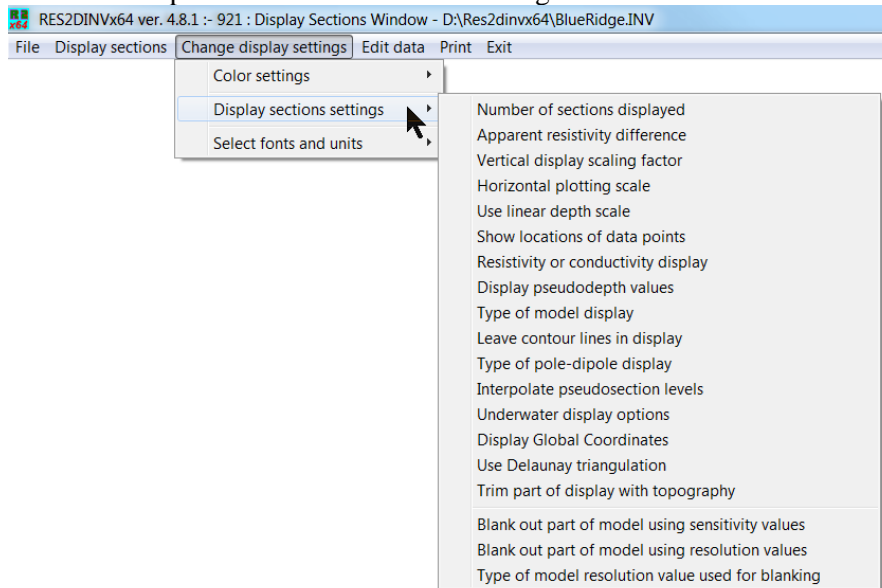

Number of sections displayed - You can choose to display 1, 2 or 3 sections on the screen. By default, all the 3 sections (the observed and calculated apparent resistivity pseudosections and the model section) are displayed.

Apparent resistivity difference - You can choose to display either the calculated apparent resistivity pseudosection itself, or the percentage difference between the logarithms of the calculated and observed apparent resistivity values.

Vertical display scaling factor - This option allows you to specify the ratio of the vertical scale to the horizontal scale, i.e. the vertical exaggeration factor, in the display. Convenient values to use are 2.0, 1.5 and 1.0. If you enter a value of 0.0, the program will use a default scaling factor so that the display can fit into the display screen.

Horizontal plotting scale - This allows you to change the horizontal scale, in terms of number of pixels per unit electrode spacing. This option is useful when you want to plot the results from different survey lines with different numbers of electrodes, with the same scale.

Use linear depth scale - The program normally displays the depths to the centers of the model layers when it displays the model section. The thickness of the layers usually increase with depth, so the corresponding depth markers are not equally spaced. This option can be used to display the depth markers with a constant spacing.

Show locations of data points - By default, the location of the data points (and centers of the model blocks) will be shown by white dots in the color pseudosection display. You can choose not to display the dots with this option.

Resistivity or conductivity display - The resistivity pseudosections and model sections are normally displayed. However, you can display the sections using conductivity values (i.e. the reciprocal of the resistivity) which is more commonly used in certain fields, such as hydrogeology.

Display pseudodepth values - For the apparent resistivity pseudosections, you can display the pseudodepth values on the vertical scale, or display the electrode spacing and “n” factors (where applicable).

Type of model display - In this option, you can display the resistivity values in the model section in the form of contours (the default choice), or in the form of rectangular blocks which constitute the inversion model. The contoured section makes it easier to visualize geological structures, while finer features might be more easily detected in the rectangular blocks section.

Leave contour lines in display - This option will draw the contour lines as black lines.

Type of pole-dipole display - This option is only relevant for pole-dipole data sets with measurements with the “forward” and “reverse” pole-dipole arrays (see Appendix A). Here you can choose to display the apparent resistivity values measured with the array in the “forward” or “reverse” configuration.

Interpolate pseudosection levels - Certain types of non-conventional array measurement sequences can result in an arrangement of the data points in the pseudosection with only one data point at some data levels. This results in a very jagged appearance in the outline of the pseudosection. This option will

interpolate the pseudosection contour plot to reduce the jagged appearance for cases with data levels with only one point. Alternatively, you can use the ‘Delaunay triangulation’ option.

Underwater display options - This covers the display of model sections for an underwater survey with the electrodes on the river, lake or sea bed (section 7.9.1). The first option in the following dialog box extends the model section drawn to the surface boundary of the water bottom. What a contoured display is used, normally the centers of the model blocks are used which in the case of the topmost layer is slightly below the water bottom boundary. Thus, in the normal display there is a slight gap between the top of the model section and water bottom. Figure 42 shows an example of a plot with both options enabled. Note this gap does not appear if the model section is drawn with rectangular blocks. In the second option, the color of the water layer can be changed to match the resistivity values in the contour scale used for the model display.

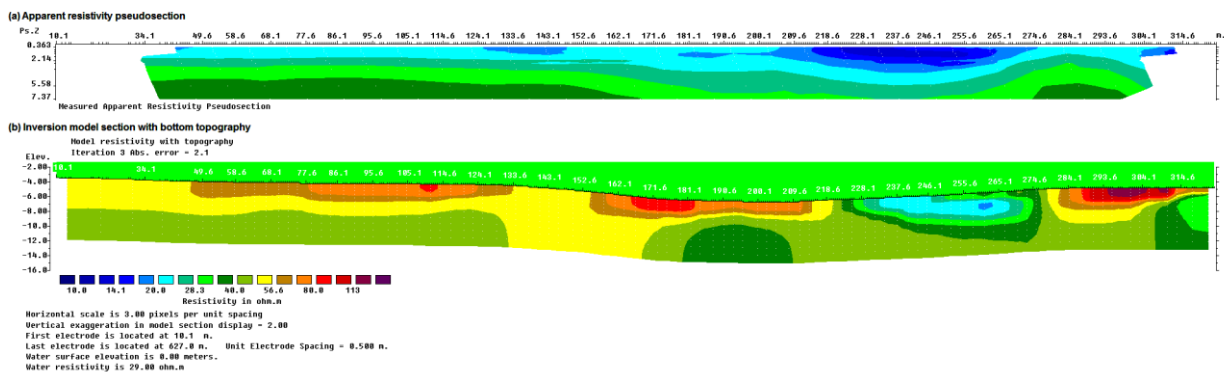
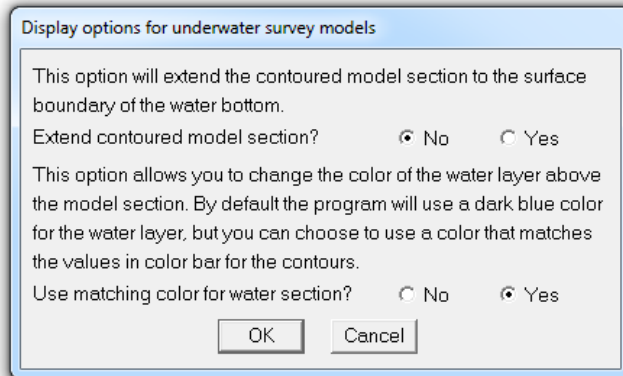
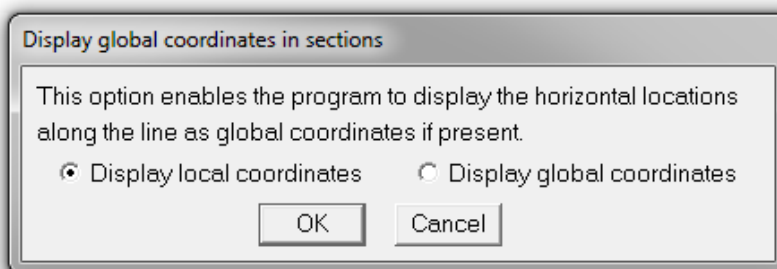

Figure 42. Example of underwater survey. (a) Apparent resistivity pseudosection. (b) Model section with topography. Note the contoured model plot has been extended upwards to the water bottom interface, and the color of the water layer matches the contour scale used for the resistivity sections. This example is from an underwater riverbed survey by Sage Engineering, Belgium.

Display Global Coordinates - This option will display the global coordinates instead of the local coordinates along the line, if the global coordinates were given the data file.



Use Delaunay triangulation - The program normally uses a simple triangulation method to draw the apparent resistivity pseudosection where the data points are arranged row by row according to their pseudodepths. This works well for most data sets, particularly those measured using a conventional array

with a uniform spacing between adjacent electrodes. In some cases, particularly for data in the general array format, where the spacings between the electrodes is non-uniform, the pseudosection does not have a simple contoured form. This is because the data points cannot be arranged into a small number of levels with uniform pseudodepths due to small variations in the electrode spacings. In such cases, an alternative method to draw the pseudosection using Delaunay triangulation can be used.

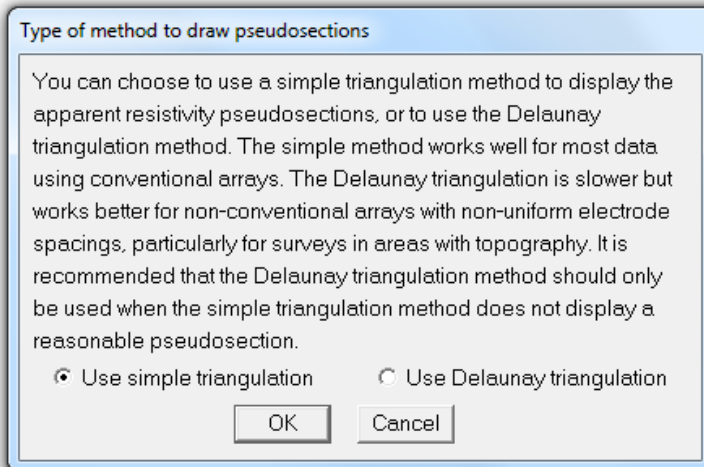

Blank out part of model using sensitivity values - This option will allow you to blank out parts of model that have low sensitivity values using the following dialog box.

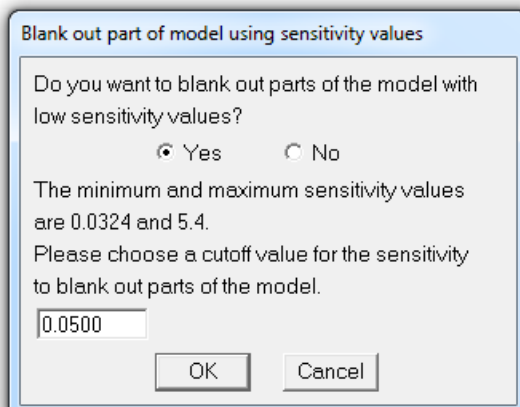

Blank out part of model using resolution values - This is similar to the previous option expect the model resolution per unit area values is used to select areas of the model to blank out. This option can only be used if the option to calculate the model resolution values was enabled before running the inversion of the data file (see section 11.4.6).

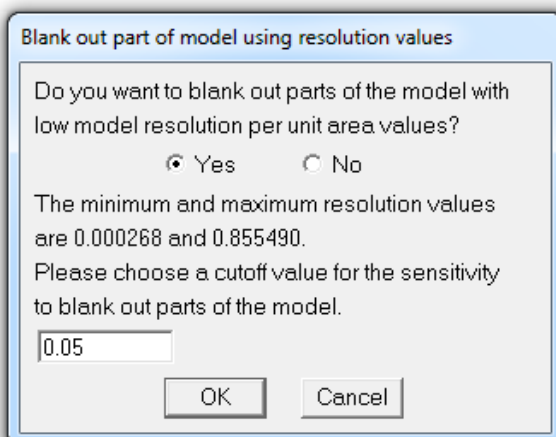

Type of model resolution value used for blanking - This selects the type of model resolution used to blank out parts of the model with low resolution values. The various options are in the following dialog box.

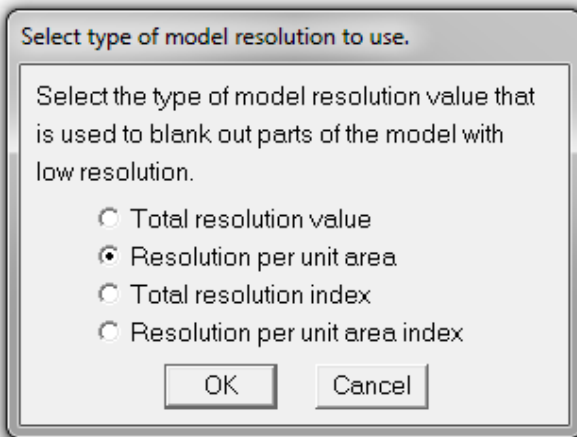

14.3.3 Select fonts and units

These options can be used to change the font of the characters used in labeling the sections, and to use feet instead of meters. The following sub-options are displayed when this menu option is selected.

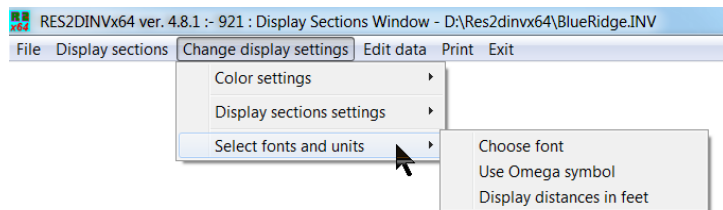

Choose font - This option is used to select the font used to display text in the model sections.

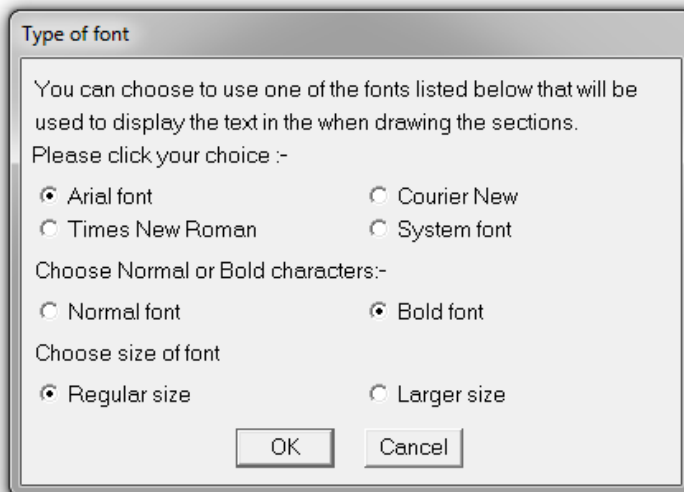

Use Omega symbol - This option allows the user to select the word 'ohm' or the Greek symbol Ω to label the resistance or resistivity values in the model sections display.

Display distances in feet - This allows the user to display distances in feet instead of the default meters.

14.4 Edit data

The following option is displayed on selecting this menu option.

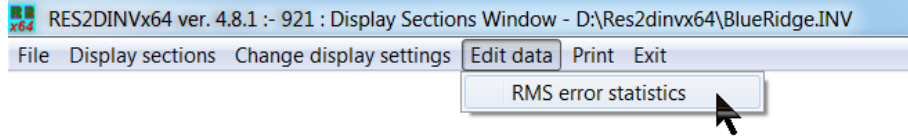

This option displays the measured and calculated apparent resistivity (and I.P. if present) as statistical plots in the form of bar charts and scatter plots. It can be used to filter out data points with high misfits to create a filtered data set which can be used for a new inversion.

14.4.1 RMS error statistics

This displays the data misfit between the measured and calculated apparent resistivity values in the form of a histogram as shown in Figure 43a. This option can be used to filter out data outliers. Data with normal random noise will show an exponential decrease in the number of data points with increasing data misfit, as in the initial part of Figure 43a. Data outliers are likely to have much higher data misfit values which can be used to separate them from the other data points, as shown by a data point on the right end of the histogram in Figure 43a. In this option, the user selects a data misfit cutoff value. The data points that will be removed are marked in red in the scatter plot on the right. If I.P. data is present, the scatter plot for the apparent I.P. data points will also be displayed (Figure 43b). When you exit this window, the program will prompt the user to save the trimmed data set into a new file.

On the top menu bar, there are a few options as shown below.

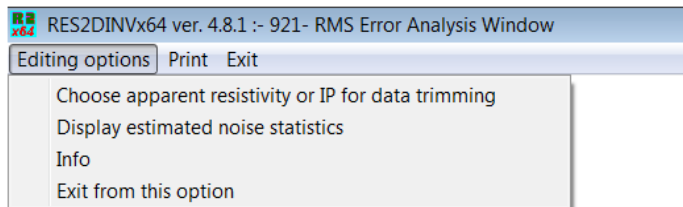

Choose apparent resistivity or IP for data trimming :- This option will display the following dialog box.

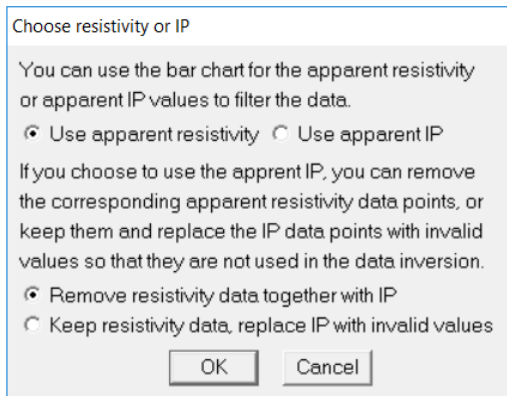

This selects the apparent resistivity or apparent I.P. data misfit values for the histogram plot. If you select the option to remove the data points based on the apparent I.P. misfit, you can remove both the apparent resistivity and I.P. values, or retain the resistivity values while removing the I.P. value.

Display estimated noise statistics :- If the input data has error values for each data point, such as from reciprocal measurements (see section 7.7), the program will also calculate a normalized data misfit. If the error values are not present, the program will attempt to estimate the error values from the data misfits. For the L1-norm data misfit, the normalized data misfit (L_{1N}) is given by

$$L_{1N} = \frac{1}{m} \sum_{j=1}^m \left| \frac{\rho_{cj} - \rho_{mj}}{\Delta\rho_{mj} + \varepsilon} \right|$$

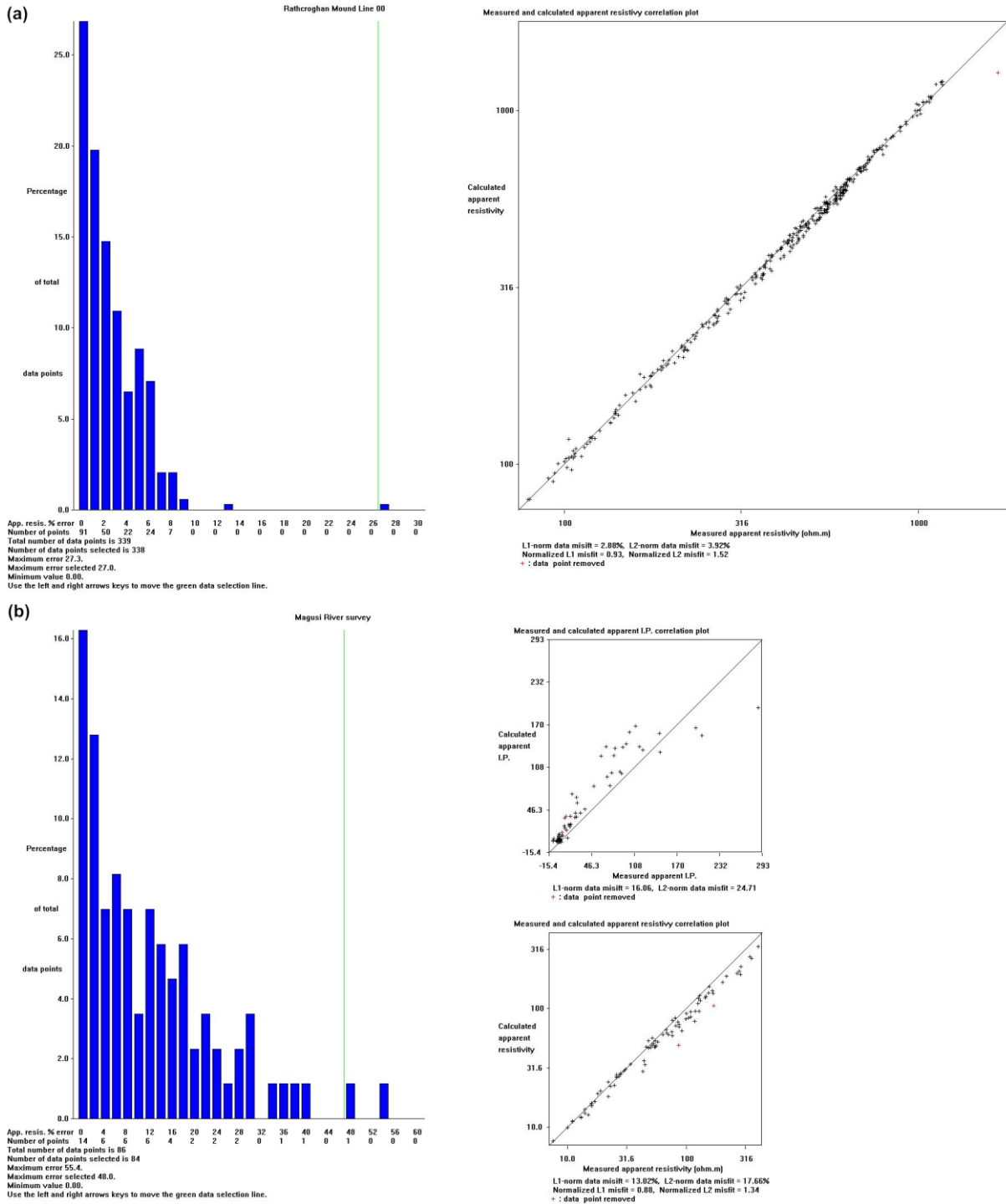

Figure 43. Histogram and scatter plots for the inversion results of the (a) RATHCRO.DAT and (b) IPMAGUSI.DAT data sets.

where ρ_c and ρ_m are the calculated and measured apparent resistivity values and $\Delta\rho_m$ is the estimated error. In some cases, the estimated error might be zero if the normal and reciprocal measurements give the same apparent resistivity value due to the limited accuracy of the measuring instrument. To avoid an infinite value for the normalized misfit, we add a small positive value ε to the denominator. The L2-norm data misfit is calculated in a similar way using the following equation.

$$L_{2N} = \sqrt{\frac{1}{m} \sum_{j=1}^m \left(\frac{\rho_{cj} - \rho_{mj}}{\Delta\rho_{mj} + \varepsilon} \right)^2}$$

Ideally the normalized misfits should be about 1.0 if the calculated values fit the data to within the noise level.

Acknowledgements

Dr. Torleif Dahlin of Lund University in Sweden provided the interesting and challenging Odarslov Dyke, Gladkvarn and Knivsas data sets. The Grundfor and Cromer data sets were kindly provided by Dr. Niels B. Christensen of the University of Aarhus in Denmark and Dr. Torleif Dahlin. The Rathcroghan data set was kindly provided by Dr. Kevin Barton and Dr. Colin Brown from data collected by the Applied Geophysics Unit of University College Galway, Ireland. Dr. Andrew Binley of Lancaster University kindly provided the cross-borehole field data set. Mr. Ernst Neiderleithinger of Buro Fur Geophysik Lorenz (Germany) supplied the Landfill data set that provided the initial motivation to write this program to handle large 2-D data sets. I am also grateful to Prof. Douglas Oldenburg of the University of British Columbia in Canada for pointing out some of the possible advantages of using equation (2). The Bauchi data was provided by Dr. Ian Acworth of School of Civil and Environmental Engineering, The Un. of New South Wales, Australia. Many thanks to Richard Cromwell and Rory Retzlaff of Golder Assoc. (Seattle) for the survey example to map holes in a clay layer. Bill Seaton of ATS, Virginia kindly provided the BLUERIDGE.DAT data set. I would also like to thank Ron Kaufman of Technos Inc. for his permission to use the Lake Lelia underwater field survey example. I would like to acknowledge Michel Ritz of IRD, France for kindly providing the BOREHOLE_TOPO.DAT example data set. The data set for the floating electrodes survey along the São Francisco River in Brazil was kindly provided by Rodrigo Machado. Finally, a special thanks to Ron Barker of The University of Birmingham (U.K.) for the Birmingham time-lapse, Stud Farm bedrock survey and the Clifton (with Julian Scott) data sets.

References

- Acworth, R. I., 1987. The development of crystalline basement aquifers in a tropical environment: *Quarterly Journal Engineering Geology*, **20**, 265-272.
- Barker, R. and Moore, J., 1998. The application of time-lapse electrical tomography in groundwater studies. *The Leading Edge*, **17**, 1454-1458.
- Brandes, I. and Acworth, R.I., 2003. Intrinsic negative chargeability of soft clays. *ASEG Extended Abstracts*, 2003, 1-4.
- Christensen N.B. and Sorensen K.I., 1994. Integrated use of electromagnetic methods for hydrogeological investigations. *Proceedings of the Symposium on the Application of Geophysics to Engineering and Environmental Problems*, March 1994, Boston, Massachusetts, 163-176.
- Claerbout, J.F. and Muir, F., 1973. Robust modeling with erratic data. *Geophysics*, **38**, 826-844.
- Dahlin, T., 1996. 2D resistivity surveying for environmental and engineering applications. *First Break*, **14**, 275-284.
- Dahlin, T. and Zhou, B., 2004. A numerical comparison of 2D resistivity imaging using ten electrode arrays. *Geophysical Prospecting*, **52**, 379-398.
- Dahlin, T. and Zhou, B., 2006. Multiple gradient array measurements for multi-channel 2D resistivity imaging. *Near Surface Geophysics*, **4**, 113-123.
- Dahlin, T., Loke, M.H., Siikanen, J. and Höök, M., 2014. Underwater ERT Survey for Site Investigation for a New Line for Stockholm Metro, in *Procs. 31st Nordic Geological Winter Meeting*, Lund, Sweden, 8-10 January 2014.
- Day-Lewis, F.D., Singha, K. and Binley, A.M., 2004. Applying petrophysical models to radar travel time and electrical resistivity tomograms: Resolution-dependent limitations. *Journal of Geophysical Research : Solid Earth*, **110**, 1 - 17.
- deGroot-Hedlin, C. and Constable, S., 1990, Occam's inversion to generate smooth, two-dimensional models from magnetotelluric data. *Geophysics*, **55**, 1613-1624.
- Edwards, L.S., 1977, A modified pseudosection for resistivity and induced-polarization. *Geophysics*, **42**, 1020-1036.
- Farquharson, C.G., 2008. Constructing piecewise-constant models in multidimensional minimum-structure inversions. *Geophysics*, **73**, K1-K9.
- Farquharson C.G. and Oldenburg D.W. 2004. A comparison of automatic techniques for estimating the regularization parameter in non-linear inverse problems. *Geophysical Journal International*, **156**, 411-425.
- Fox, R.C., Hohmann, G.W., Killpack, T.J. and Rijo, L., 1980, Topographic effects in resistivity and induced polarization surveys. *Geophysics*, **45**, 75-93.
- Hallof, P.G., 1990, Reconnaissance and detailed geophysical results, Granite Mountain Area Pershing County, Nevada. in Fink, J.B., McAlister, E.O., Sternberg, B.K., Wieduwilt, W.G. and Ward, S.H. (Eds), 1990, *Induced polarization : Applications and case histories : Investigations in Geophysics No. 4*, Soc. Expl. Geophys.
- Keller G.V. and Frischknecht F.C., 1966. *Electrical methods in geophysical prospecting*. Pergamon Press Inc., Oxford.
- Kenma, A., Binley, A., Ramirez, A. and Daily, W., 2000. Complex resistivity tomography for environmental applications. *Chemical Engineering Journal*, **77**, 11-18.
- Kim, J H., M J. Yi, S G., Park, and J.G. Kim, 2009. 4-D inversion of DC resistivity monitoring data acquired over a dynamically changing earth model. *Journal of Applied Geophysics*, **68**, 522-532.
- Kim, J.H., 2010. 4-D inversion of resistivity monitoring data using L1 norm minimization. *Procs. 16th European Meeting of Environmental and Engineering Geophysics*, 6 - 8 September 2010, Zurich, Switzerland, A15.
- Loke, M.H., 1999. Time-lapse resistivity imaging inversion. 5th Meeting of the Environmental and Engineering Geophysical Society European Section Proceedings. Em1.
- Loke, M.H., 2000. Topographic modelling in resistivity imaging inversion. 62nd EAGE Conference & Technical Exhibition Extended Abstracts, D-2.
- Loke, M.H., 2018. Tutorial : 2-D and 3-D electrical imaging surveys. Geotomosoft Solutions, Malaysia. (Available for download from www.geotomosoft.com)
- Loke, M.H. and Barker, R.D., 1996, Practical techniques for 3D resistivity surveys and data inversion. *Geophysical Prospecting*, **44**, 499-523.
- Loke, M.H. and Dahlin, T., 2002. A comparison of the Gauss-Newton and quasi-Newton methods in resistivity imaging inversion. *Journal of Applied Geophysics*, **49**, 149-162.

- Loke, M.H., Acworth, I. and Dahlin, T., 2003. A comparison of smooth and blocky inversion methods in 2D electrical imaging surveys. *Exploration Geophysics*, **34**, 182-187.
- Loke, M.H. and Dahlin, T., 2010. Methods to Reduce Banding Effects in 3-D Resistivity Inversion. Near Surface 2010 – 16th European Meeting of Environmental and Engineering Geophysics 6 - 8 September 2010, Zurich, Switzerland, A16.
- Loke, M.H., Wilkinson, P. and Chambers, J., 2010a. Fast computation of optimized electrode arrays for 2D resistivity surveys. *Computers & Geosciences*, **36**, 1414-1426.
- Loke, M.H., Wilkinson, P. and Chambers, J., 2010b. Parallel computation of optimized arrays for 2-D electrical imaging. *Geophysical Journal International*, **183**, 1202-1315.
- Loke, M.H., Chambers, J.E., Rucker, D. F., Kuras, O. and Wilkinson, P. B., 2013. Recent developments in the direct-current geoelectrical imaging method. *Journal of Applied Geophysics*, **95**, 135-156.
- Loke, M.H., Dahlin, T. and Rucker, D.F., 2014. Smoothness-constrained time-lapse inversion of data from 3-D resistivity surveys. *Near Surface Geophysics*, **12**, 5-24.
- Loke, M.H., Kiflu, H., Wilkinson, P.B., Harro, D. and Kruse, S., 2015. Optimized arrays for 2-D resistivity surveys with combined surface and buried arrays. *Near Surface Geophysics*, **13**, 505-517.
- Nelson, G.D. and Van Voorhis, 1973, Letter to the editor regarding the paper “Complex resistivity spectra of porphyry copper mineralization”. *Geophysics*, **38**, 984.
- Niederleithinger, E., 1994, Use of high resolution geomagnetics, 2D-DC-geoelectrics and induced polarisation in environmental investigations. Paper presented at SAGEEP '94, Boston, USA.
- Oldenburg, D.W. and Li., Y., 1999. Estimating depth of investigation in dc resistivity and IP surveys. *Geophysics*, **64**, 403-416.
- Olivar, A., de Lime, L. and Sharma, M.M., 1990. A grain conductivity approach to shaly sandstones. *Geophysics*, **55**, 1347-1356.
- Robain, H., Albouy, Y., Dabas, M., Descloitres, M., Camerlynck, C., Menchler, P. and Tabbagh, A., 1997, The location of infinite electrodes in pole-pole electrical surveys: consequences for 2D imaging. *Journal of Applied Geophysics*, **41**, 313-333.
- Rucker, D., Fink, J.B. and Loke, M.H., 2011a. Environmental Monitoring of Leaks using Time Lapsed Long Electrode Electrical Resistivity. *Journal of Applied Geophysics*, **74**, 242-254.
- Rucker, D.F., Noonan, G.E. and Greenwood, W.J., 2011b. Electrical resistivity in support of geological mapping along the Panama Canal. *Engineering Geology*, **117**, 121-133.
- Sasaki, Y., 1992, Resolution of resistivity tomography inferred from numerical simulation. *Geophysical Prospecting*, **40**, 453-464.
- Scott, J.B.T., Barker, R.D. Peacock, S., 2000. Combined seismic refraction and electrical imaging. *Procs. 6th Meeting of the European Association for Environmental and Engineering Geophysics*, 3-7 Sept. 1997, Bochum, Germany, EL05.
- Seaton, W.J. and Burbey, T.J., 2000. Aquifer characterization in the Blue Ridge physiographic province using resistivity profiling and borehole geophysics : Geologic analysis. *Journal of Environmental & Engineering Geophysics*, **5**, no. 3, 45-58.
- Silvester, P.P. and Ferrari, R.L., 1990, *Finite elements for electrical engineers* (2nd. ed.). Cambridge University Press.
- Slater, L., Binley, A.M., Zaidman, M.D. and West, L.J., 1997, Investigation of vadose zone flow mechanisms in unsaturated chalk using cross-borehole ERT. *Proceedings of the EEGS European Section 3rd Meeting*, Aarhus, Denmark, 17-20.
- Summer, J.S., 1976, *Principles of induced polarization for geophysical exploration*. Elsevier Scientific Publishing Company.
- Tong, L. and Yang, C., 1990, Incorporation of topography into two-dimensional resistivity inversion. *Geophysics*, **55**, 354-361.
- Van Voorhis, G.D. Nelson, P.H. and Drake, T.L., 1973, Complex resistivity spectra of porphyry copper mineralization. *Geophysics*, **38**, 49-60.
- Waddell, J. and Barton, K., 1995, Seeing beneath Rathcroghan. *Archaeology Ireland*, Vol. **9**, No. 1, 38-41.
- White, R.M.S., Collins, S. and Loke, P., 2003. Resistivity and IP arrays, optimised for data collection and inversion. *Exploration Geophysics*, **34**, 229-232.
- Witherly, K.E. and Vyselaar, J., 1990, A geophysical case history of the Poplar Lake Copper-Molybdenum deposit, Houston Area, British Columbia. in Fink, J.B., McAlister, E.O., Sternberg, B.K., Wieduwilt, W.G. and Ward, S.H. (Eds), 1990, *Induced polarization : Applications and case histories : Investigations in Geophysics No. 4*, Soc. Expl. Geophys.

Zhou B. and Dahlin, T., 2003, Properties and effects of measurement errors on 2D resistivity imaging surveying, *Near Surface Geophysics*, 1, 105-117.

Appendix A Array types in RES2DINV

A list of the arrays supported by the RES2DINV program together with their number codes is given below.

Table 40. Array types and their number codes.

Array name	Number code	Number of electrodes
Wenner (Alpha)	1	4
Pole-Pole	2	2
Inline Dipole-Dipole	3	4
Wenner (Beta)	4	4
Wenner (Gamma)	5	4
Pole-Dipole	6	3
Wenner-Schlumberger	7	4
Equatorial dipole-dipole	8	4
Offset pole-dipole (only used as sub-array number with data in the general array format)	10	3
Non-conventional or general array	11	2 to 4
Cross-borehole survey (apparent resistivity values)	12	2 to 4
Cross-borehole survey (resistance values)	13	2 to 4
Gradient array (only used as sub-array number with data in the general array format)	15	4

A description of the different arrays types is given in the free tutorial notes on electrical imaging (Loke 2018). Figure 44 shows the arrangement of the electrodes for some commonly used arrays. In general, for an array with 4 electrodes, there are 3 possible arrangements for the electrodes. The Wenner array has three different variations. The "normal" Wenner array is actually the Wenner alpha array. The Wenner beta array is a special case of the dipole-dipole array where the "n" factor is always 1. The RES2DINV program will automatically convert a Wenner beta array data file into a dipole-dipole array data set.

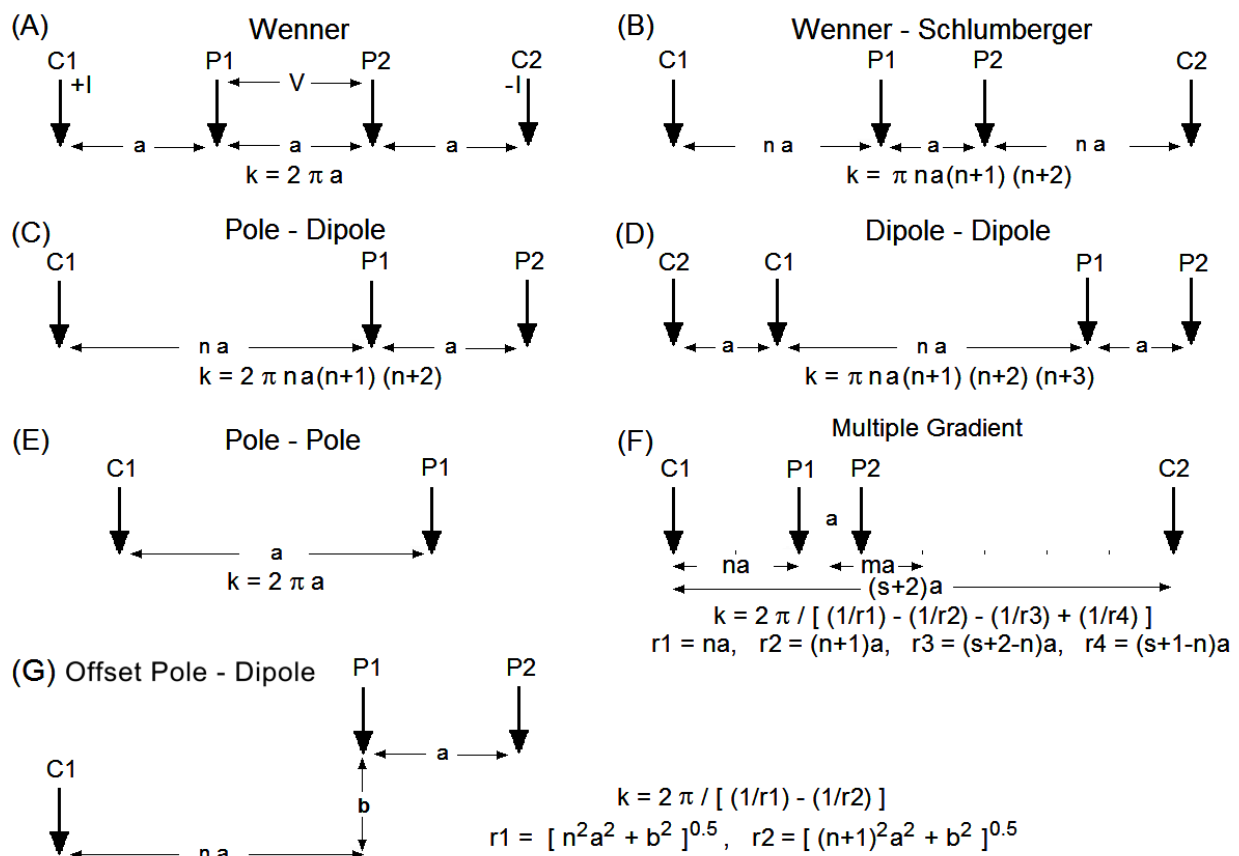

Figure 44. Arrangement of the electrodes for some commonly used arrays and their geometric factors.

The general array with number code 11 is always given with a secondary sub-array number code. If the arrays are actually one of the conventional arrays, the number code for the conventional array is used as the sub-array number (for example if it is a dipole-dipole array the sub-array number is then 3). If it is not one of the conventional arrays, or if it is a mixture of different arrays (such as the dipole-dipole and gradient), the sub-array number is given as 0.

The 'forward' and 'reverse' variations of the pole-dipole array are shown in Figure 45. If an offset dipole-dipole array is used, the general array data format should be used with a sub-array type of 0.

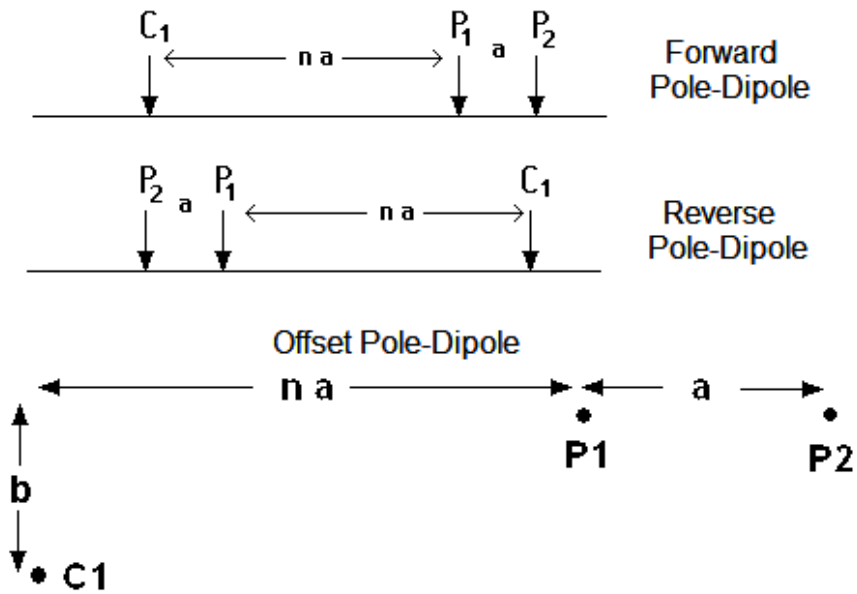

Figure 45. Normal, reverse and offset pole-dipole array arrangements.

Appendix B Special OhmMapper Note

Data collected by the OhmMapper system can be converted into the format used by the RES2DINV program using the 'DataMap for OhmMapper' program provided by Geometrics, Inc. This is a Windows based program. After starting the program, please click the EXPORT option to carry out the data conversion. For further details, please refer to the OhmMapper manual provided by Geometrics. The figure below shows an example of a data set collected by the OhmMapper system together with the inversion model produced by the RES2DINV program. The survey was conducted over an area with weathered granite. The data set is given in the file OHMMAPPER.DAT. The measurements were made using the dipole-dipole array with a dipole length "a" spacing of 10 metres and with n values of 0.5 to 3.5. The data set has 732 data points while the inversion model consists of 1240 cells.

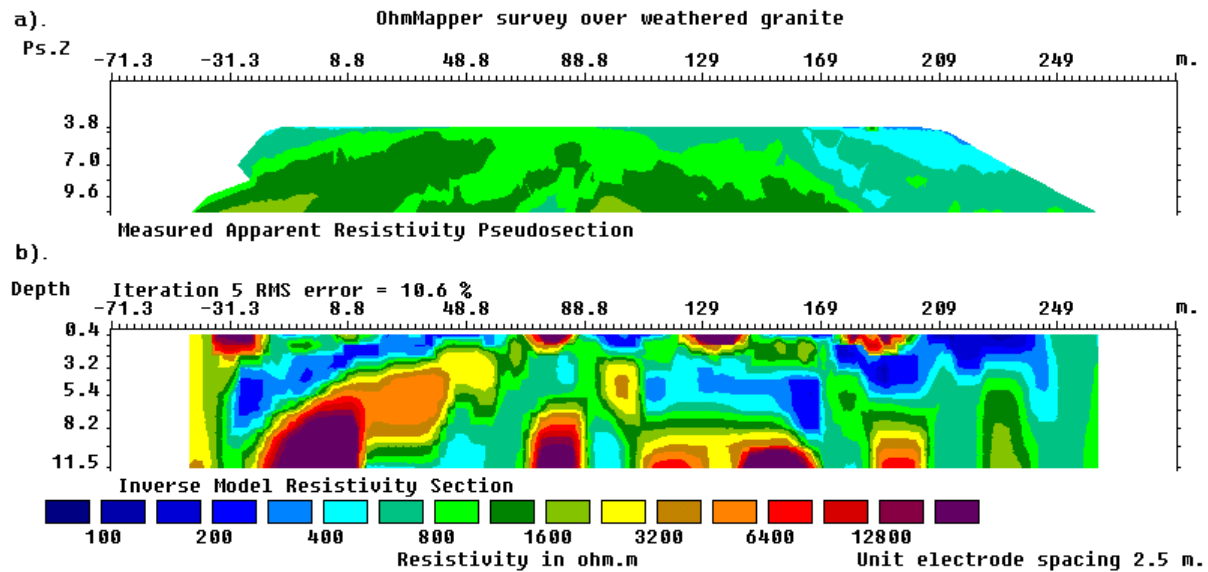
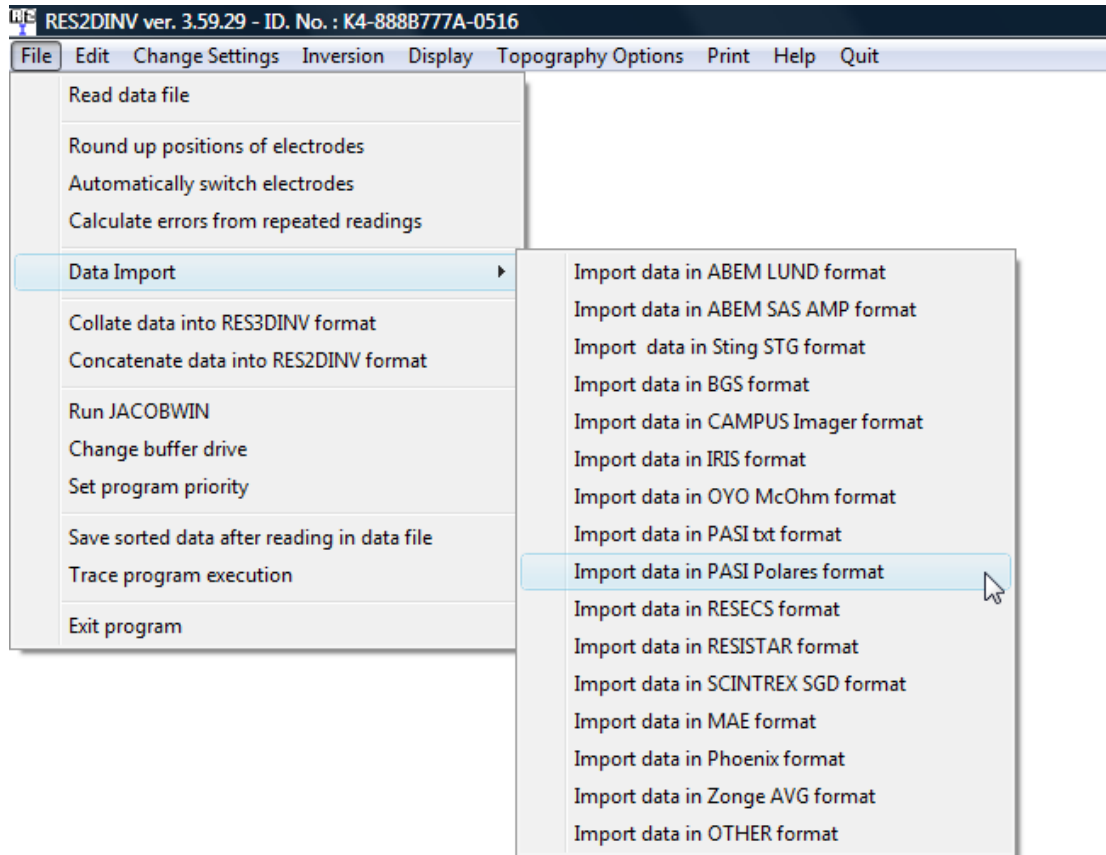

Figure 46. Example OhmMapper data set and inversion model. (a) Apparent resistivity pseudosection measured with an OhmMapper mobile resistivity surveying system. (b) Model section obtained by RES2DINV program.

Appendix C Converting data from the PASI instruments

The PASI resistivity meters use two types of data formats, the older text format with a 'txt' extension and a newer 'ptf' binary format. To convert the files into the format used by the RES2DINV program, click 'File – Data Import' on the main menu and then select the appropriate option in the list as shown below.



After clicking the PASI format option, a dialog box will be displayed to select the 'txt' or Polares format data file. As an example, if you had selected the option to import a 'txt' file, the following dialog box will be displayed.

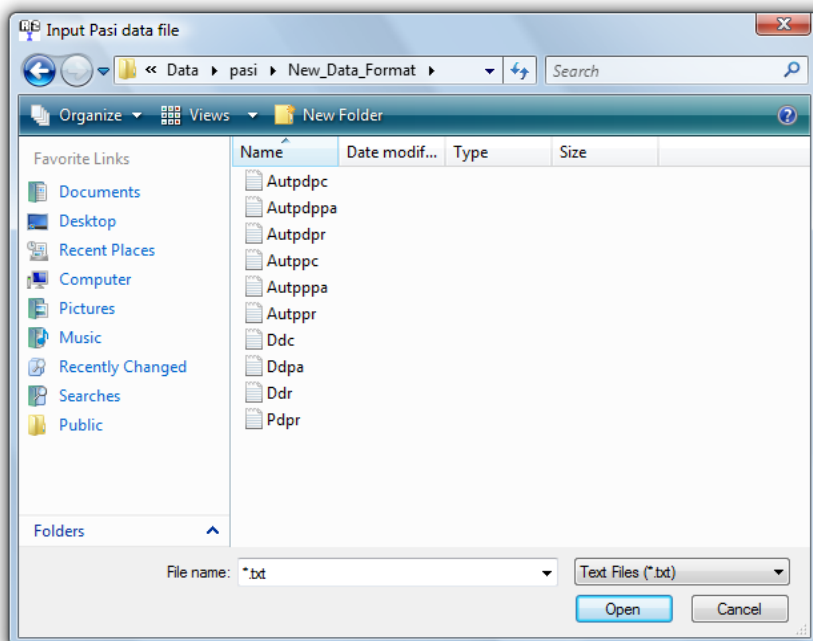

Selecting the option to import a Polares 'ptf' data file will bring up the following dialog box.

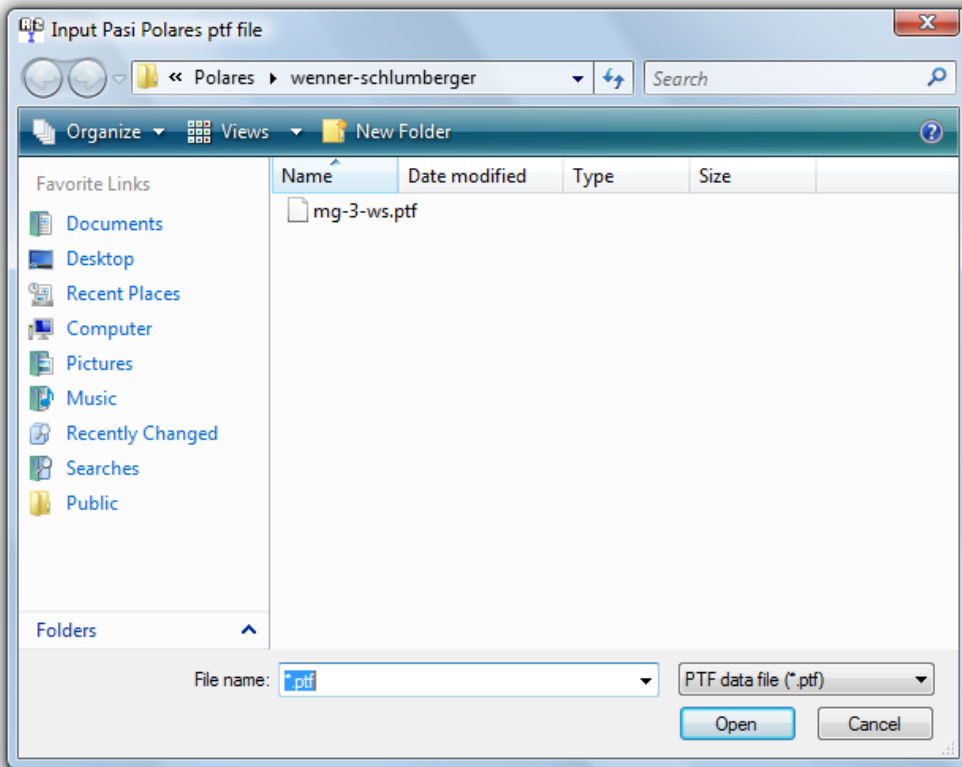

The program will then convert the data, and prompt the user for the name of the file with the 'dat' extension to save the converted data in the RES2DINV format.

Appendix D Surveys with electrodes suspended in a water layer

The two arrangements for aquatic surveys have the electrodes on the seabed (section 7.9.1) or floating on the water surface (section 7.9.2) have disadvantages if a mobile system is used. If the water layer is thick, the resolution will be very poor with floating electrodes as most of the current will flow within the water layer and very little penetrates into the sub-bottom materials which are of interest. Dragging the cable along the bottom might lead to other problems, such as the cable being snagged by debris on the seabed. The third possible arrangement is to have the cable suspended a short distance (such as 1 meter) above the seabed. This has the advantage of better resolution with the electrodes closer to the targets of interest while avoiding obstacles on the seabed. The example file `Suspended-Streamer-Aquatic-Survey.dat` file (Table 41) shows the data format for this type of situation. After the section with the water layer parameters, a header 'Suspended streamer used' is used to indicate that the electrode are not on the water bottom but suspended in the water layer. This is followed by the main section giving the elevation of the streamer along the profile. This data set is from a synthetic model with the cable 4 meters below the water surface and 1.0 to 1.5 meters above an uneven seabed with a depth of 5.0 to 5.5 meters below the surface. The water region is modeled by a finite-element mesh. The vertical positions of the nodes in the mesh are automatically adjusted to take into account variations in the water thickness (Figure 47) with adjustments at the appropriate nodes to fit the actual depths of the electrodes along the profile. Figure 48 shows the pseudosection and inversion model for the example data file.

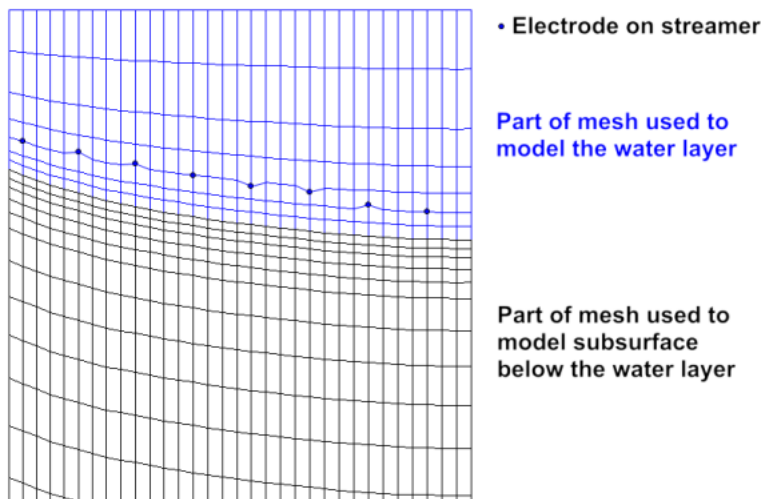

Figure 47. Mesh used to model water layer.

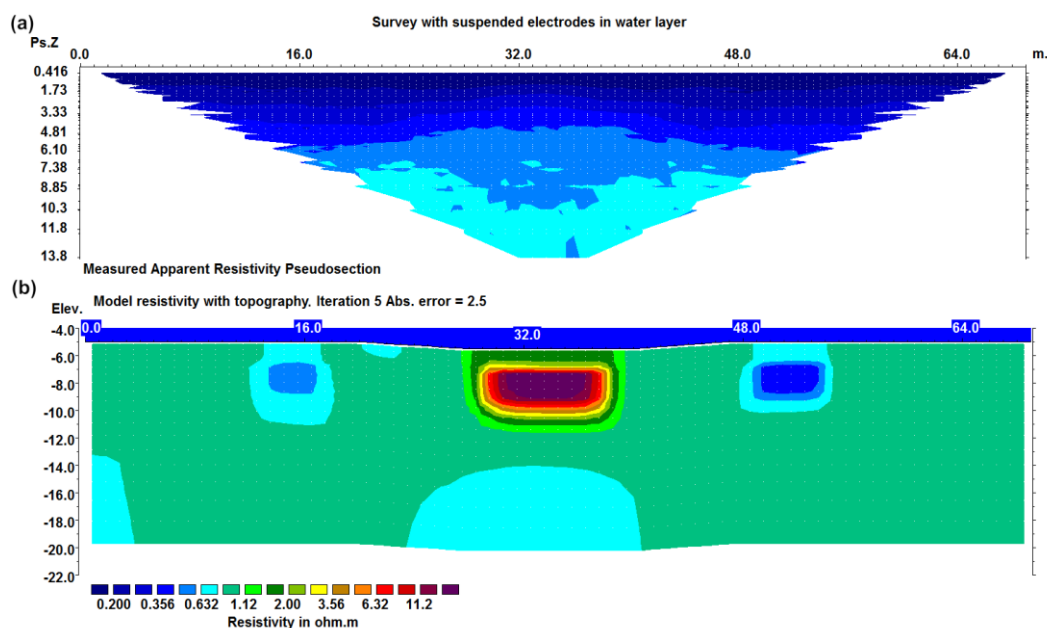

Figure 48. Example data set and inversion model for a survey with a streamer suspended in a water layer. (a) Apparent resistivity pseudosection and (b) inversion model section.

Table 41. Example data file for a survey electrodes suspended in a water layer.

<i>Suspended-Streamer-Aquatic-Survey.dat file</i>	<i>Comments</i>
Survey with suspended electrodes in water layer	<i>Title</i>
1.0	<i>Unit electrode spacing</i>
11	<i>General array type</i>
3	<i>Non-specific sub-array</i>
Type of measurement (0=app. resis, 1=resistance)	<i>Header</i>
0	<i>0 to indicate apparent resistivity given</i>
2172	<i>Number of data points</i>
1	<i>Indicates true horizontal x-distances</i>
0	<i>No I.P. data</i>
4 1.0,0.0 0.0,0.0 2.0,0.0 3.0,0.0 0.15426	<i>First 3 data points in general</i>
4 2.0,0.0 1.0,0.0 3.0,0.0 4.0,0.0 0.15422	<i>array data format. Note water</i>
4 3.0,0.0 2.0,0.0 4.0,0.0 5.0,0.0 0.15409	<i>surface at 0.0 meter elevation</i>
..	
..	<i>Similar format for other data</i>
..	<i>points</i>
4 12.0,0.0 4.0,0.0 60.0,0.0 68.0,0.0 0.53350	<i>Last 2 data points</i>
4 13.0,0.0 5.0,0.0 61.0,0.0 69.0,0.0 0.78482	
Topography in separate list	<i>Topography information header for general array</i>
1	<i>True x-distance</i>
8	<i>Number of topography values</i>
0.000,-5.000	<i>Topography x and z values</i>
20.00,-5.000	<i>Note this is the elevation of the true water bottom.</i>
28.00,-5.500	
30.00,-5.500	
34.00,-5.500	
40.00,-5.500	
47.00,-5.000	
69.00,-5.000	<i>Last topography data point.</i>
0	<i>No fixed regions</i>
1	<i>1 indicates survey with submerged electrodes</i>
0.300,-100.000, 200.000,0.0	<i>Resistivity, left and right limits of water layer, elevation at top of water layer</i>
1	<i>Indicates surface geometric factor used</i>
Suspended streamer used	<i>Header to indicate survey with suspended streamer</i>
Type of suspended streamer information (0=streamer,1=true water bottom)	<i>Header, to provide options for other types of information in future</i>
0	<i>Use 0 for now</i>
Number of streamer elevation data points	<i>Header</i>
7	<i>Number of values for streamer elevation profile</i>
x and z coordinates of points on streamer	<i>Header</i>
0.000,-4.000	<i>This section lists the x and z coordinates for</i>
10.00,-4.000	<i>points along the streamer profile</i>
30.00,-4.000	
35.00,-4.001	
40.00,-4.000	
60.00,-4.00	
69.00,-4.000	
0,0,0,0	<i>End with a few zeros</i>

Appendix E Plotting with Surfer

Over the years, the menu system in the Surfer program has changed. This section describes a method to plot the results using the latest version Surfer 13 (as of May 2016). As an example, we will use the inversion model saved in the RATCHRO.INV file which should be installed together with the program. First, read in this file in the ‘Display’ window using the ‘File-Read file with inversion results’ option. Next use the ‘Display sections – Model display – Include topography in model display’ option to display the model section. As example is shown in the figure below.

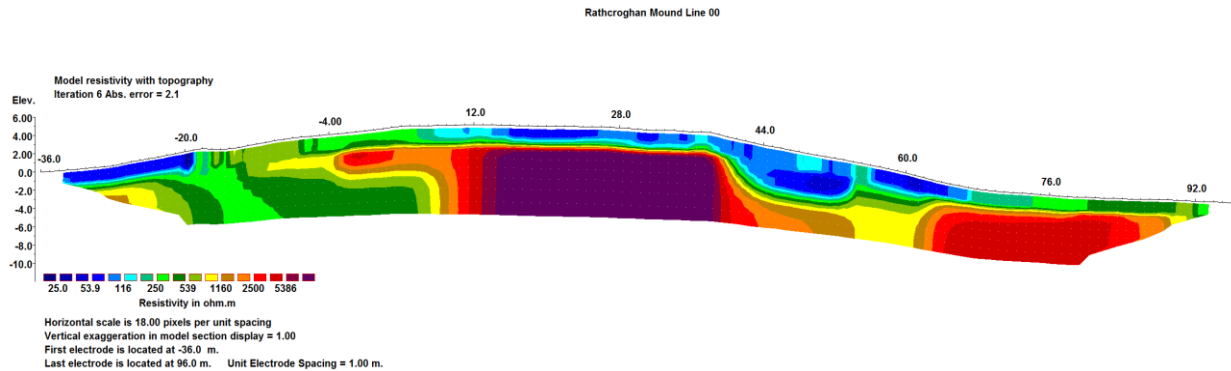

Figure 49. Example display with topography for the RATCHRO.INV file.

Note the contour intervals have been set with 25.0 as the first contour, and it increases logarithmically by a factor of 10 after every 5 contours. After displaying the model section, select the ‘File – Model export – Save data in Surfer format’ option, which will display the following dialog box.

Saving inversion results in SURFER format

Please select iteration number :

You can save the resistivity values directly or the logarithm of the values.

Save resistivity values directly Save logarithm of resistivity values

For model with topography and x-positions given as surface distances, you can save an extra set of Surfer files using the stretched linear distances.

Do not save extra set of files Save extra set of files.

Please select the values that you want to save in SURFER format.

Type of section.	Available(?)	Type of section.	Available(?)
<input type="checkbox"/> Measured apparent resistivity	<input checked="" type="checkbox"/>	<input type="checkbox"/> Calculated apparent resistivity	<input checked="" type="checkbox"/>
<input type="checkbox"/> Model resistivity	<input checked="" type="checkbox"/>	<input type="checkbox"/> Model conductivity	<input checked="" type="checkbox"/>
<input checked="" type="checkbox"/> Model resistivity with topography	<input checked="" type="checkbox"/>	<input type="checkbox"/> Model conductivity with topography	<input checked="" type="checkbox"/>
<input type="checkbox"/> Measured apparent I.P.	<input type="checkbox"/>	<input type="checkbox"/> Calculated apparent I.P.	<input type="checkbox"/>
<input type="checkbox"/> Model I.P.	<input type="checkbox"/>	<input type="checkbox"/> Model I.P. with topography	<input type="checkbox"/>
<input type="checkbox"/> Model resolution values	<input type="checkbox"/>	<input type="checkbox"/> Model resolution per unit area	<input type="checkbox"/>

Give model IP values as metal factor values? No Yes

When you click ‘Ok’ with the above settings, you will find the following files saved in the same folder as the RATCHRO.INV file. They are text files that you can view with a text editor such as NotePad.

- Rathcro_topres.dat :- Contains the model resistivity values and the centers of the blocks.
- Rathcro_topres.blm :- Surfer blanking file to blank out regions outside the model section.
- Rathcro_topres_post.dat :- File with positions of electrodes.
- Rathcro_topres.lvl :- Contains the contour values and colors.

To use the files, with Surfer, first you need to create a grid file. Start up Surfer and select the 'File-New-Plot' option if necessary to get the menu system as shown below.

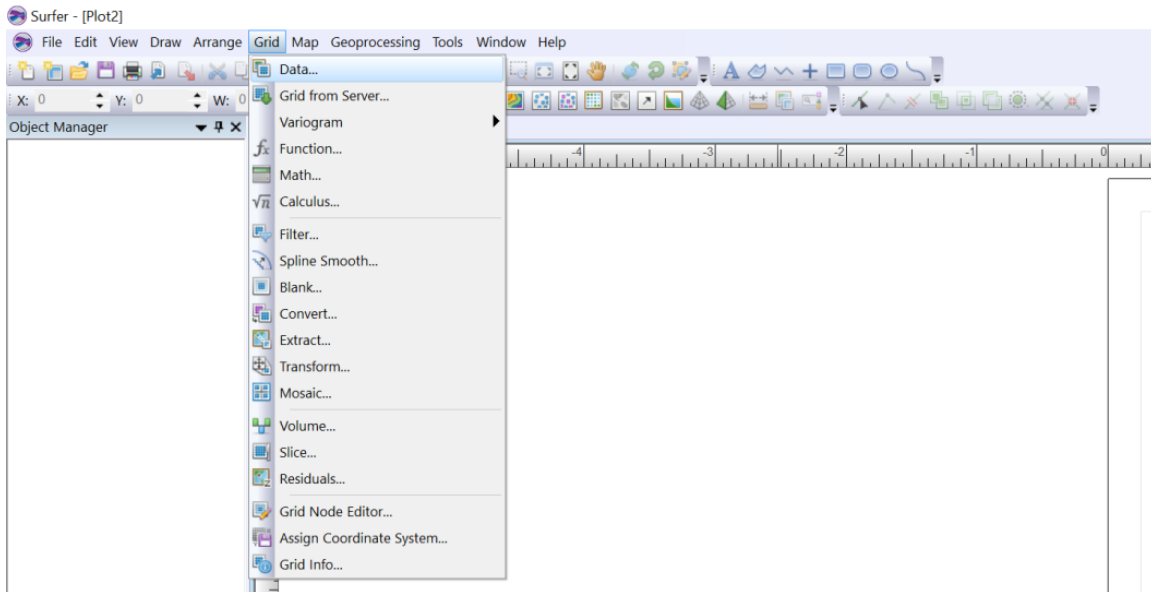

Select the 'Grid-Data' option, and then read in the 'Ratcro_modres.dat' file. Surfer will then display a dialog box with the default settings to contour the grid file. You should change the number of nodes to 5 to 10 times the values suggested by Surfer to ensure the sides of the section are smooth in your plot. In the figure below, the default values given by Surfer are 100 by 13 nodes, which have been changed to 1000 by 130 nodes. Surfer has a number of gridding options to interpolate the data values. Some methods that use a polynomial, such as the default 'Kriging' method might result in negative model resistivity values if there are large variations in the resistivity values. In the figure below, the 'Triangulation with linear interpolation' method is selected to avoid negative values.

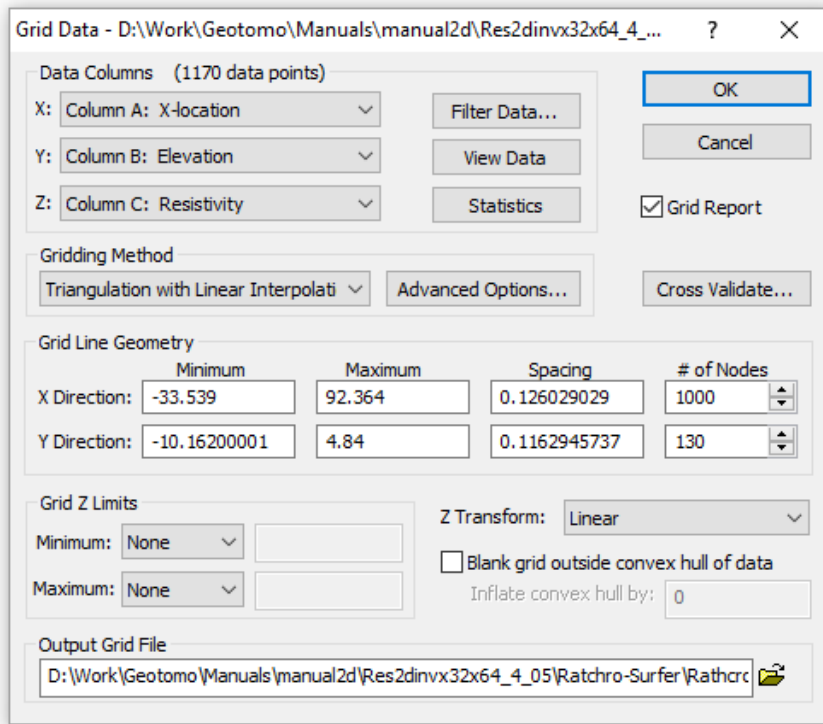

Select 'OK' and then Surfer will interpolate the values into a rectangular box that contains all the points that will be saved in a file 'Rathcro_topres.grd'. To blank out the sections of the box outside the actual model section, select the 'Grid-Blank' command, and then read in the Rathcro_topres.grd file. It will next ask for a blanking file. Read in the 'Rathcro_topres.blm' file. Surfer will next create a new grid file and

will ask you the name of the output grid file. You can set a name such as 'Rathcro_modres_bln.grd'. We will now use this new grid file to draw the section. Select the 'Map-New-Contour Map' option, and read in the 'Rathcro_topres_bln.grd' file.

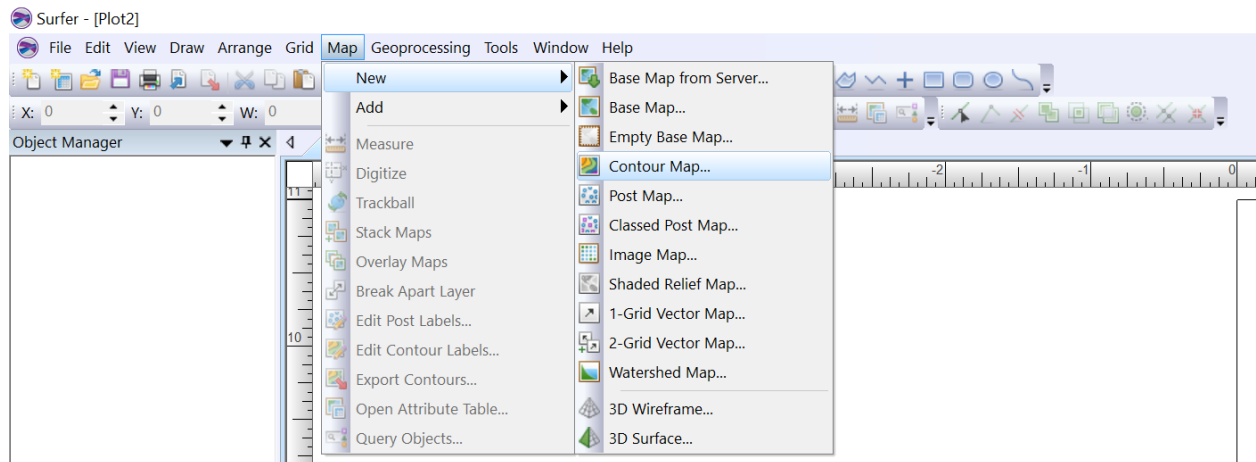

Surfer will draw the contours and display the section. Next click the 'Contour-Rathcro_topres_bln' icon in the Object Manager near the top-left section of the Surfer window. This will bring up a 'Property Manager' section below it. The options in the Property Manager will allow you to set the contours values and fill the contours with colors by select the 'Levels' tab, as shown below.

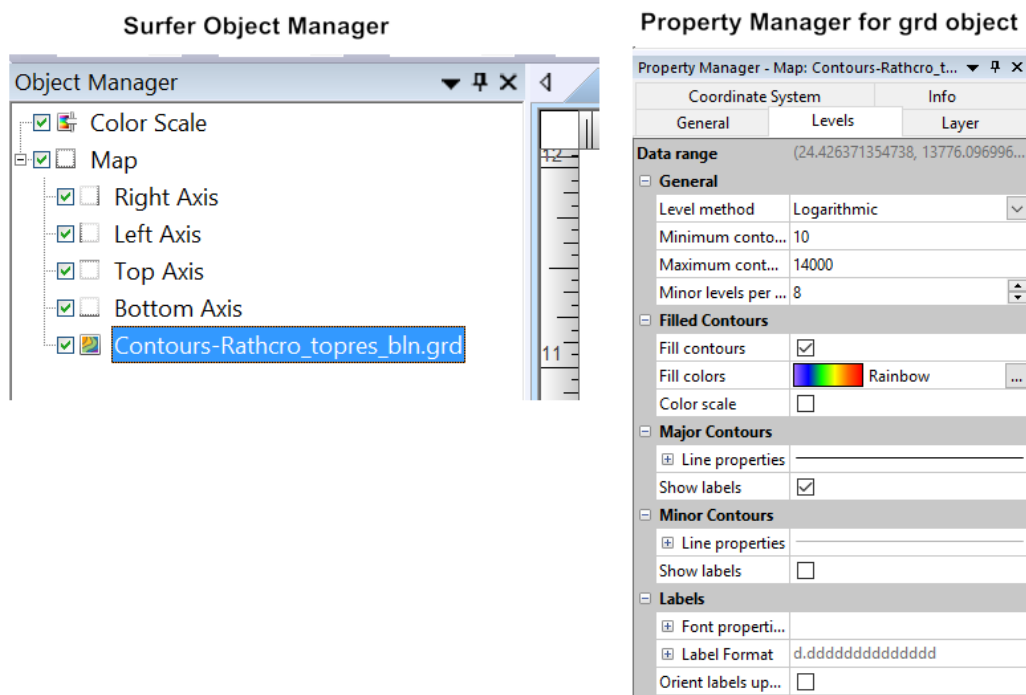

To use the same contour values and colors as in the Res2dinvx64 program, in the "Level method" tab, select the 'Advanced' option which will show the following box.

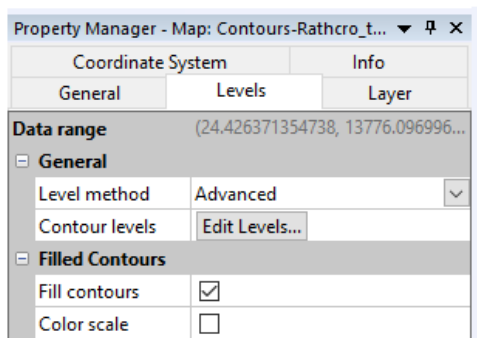

Click 'Edit Levels' which will show the following box.

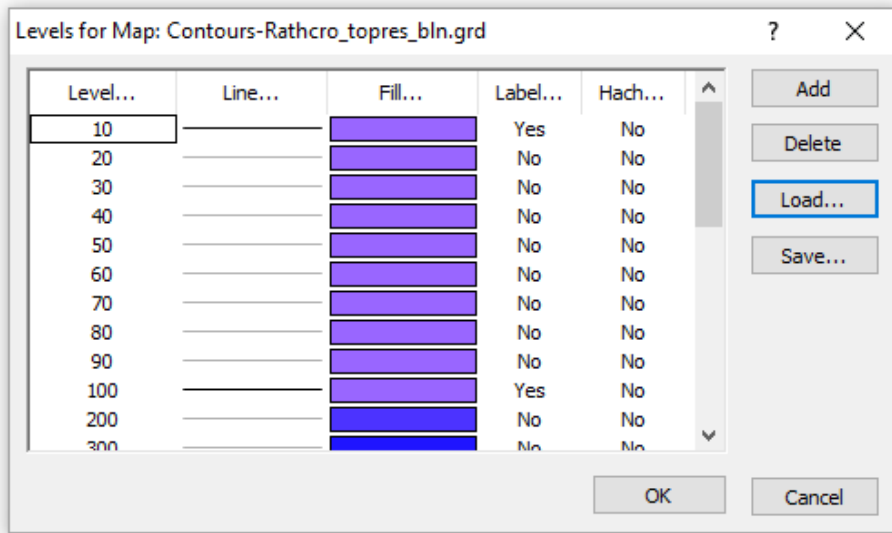

Select the 'Load' option and read in the 'Rathcro_topres.lvl' file. When you click 'OK' the model section will be redrawn using the same contour values and colors as in the Res2dinvx64 program. The next step is to load the file containing the positions of the electrodes so that they will be drawn on top of the section. Click the section drawn on the screen or the 'Contours-Rathcro_topres_bln.grd' icon in the 'Object Manager' window so that it will be selected. After that, select the 'Map-Add-Post Layer' option as shown below.

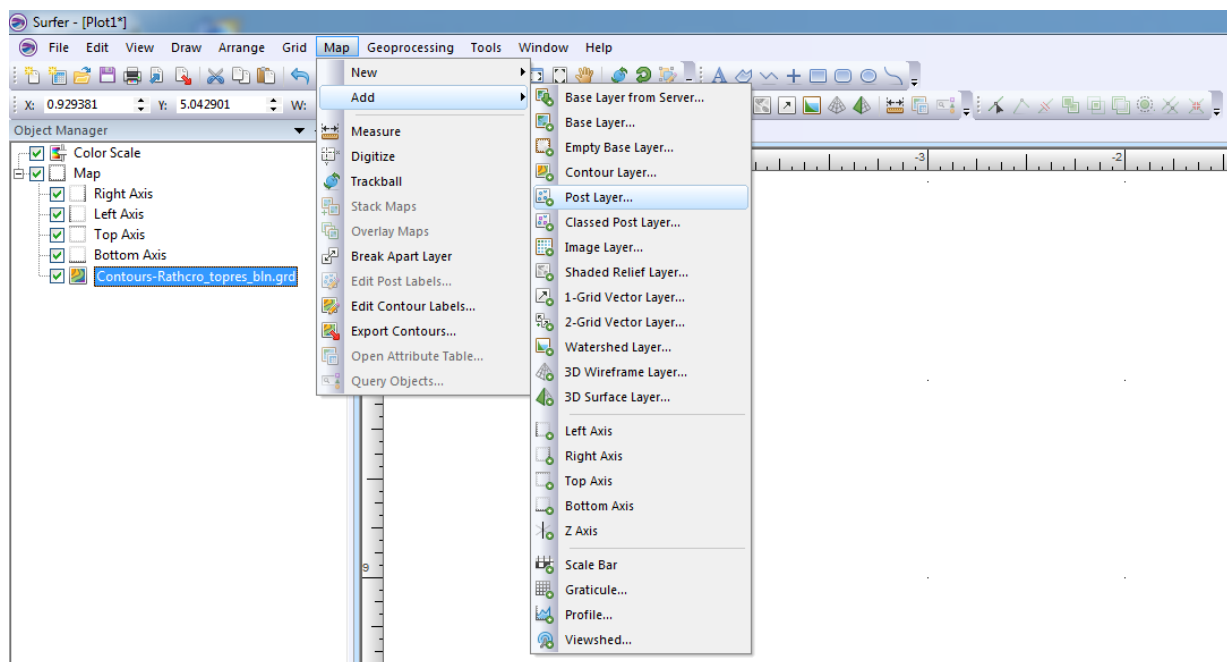

Read in the 'Rathcro_topres_post.dat' file. Surfer might show a message to adjust the map limits. Select 'Yes' and it will automatically adjust the contour plot so that it fits the post map. In the 'Object Manager' window you will now see a 'Post-Rathcro_topres_post.dat' member in the list below the 'Map' label. Click this member so that the 'Property Manager' for the plot of the electrodes will be shown. In the 'Property Manager', click the 'Symbol' tab, and then the 'Symbol properties' row, and it will show the different options to set the symbol representing the electrode. As an example, the 'Symbol set' was changed to 'Arial' and the Symbol 719 was selected to draw Figure 50. The other change to make is to draw a line joining the electrodes to represent the ground surface. Click the 'General' tab and then click the box next the 'Connect points' window.

The post icon in the Object Manager

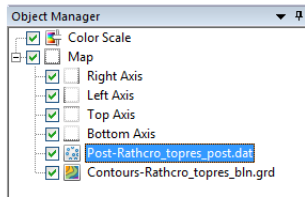

The 'Symbol' options in Property Manager

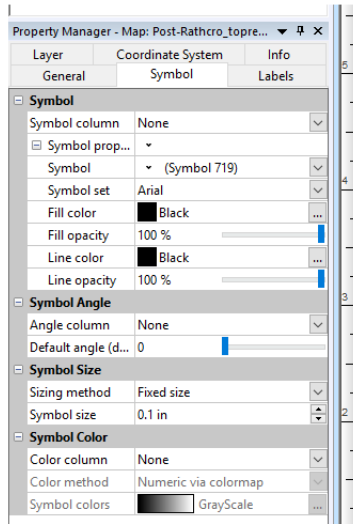

The 'General' options in Property Manager

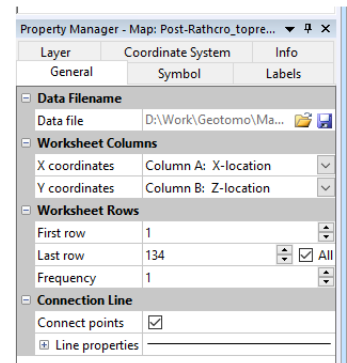

The final output is shown in Figure 50. There will be slight differences in the contour sections drawn by SURFER and RES2DINV due to the differences in the interpolation methods used. SURFER does not use the original data points, but an interpolated rectangular grid of points to draw the contours. The differences will probably be more obvious in areas with very rapid changes in the resistivity. One way to reduce the differences is to increase the number of grid lines used by SURFER for the interpolation grid.

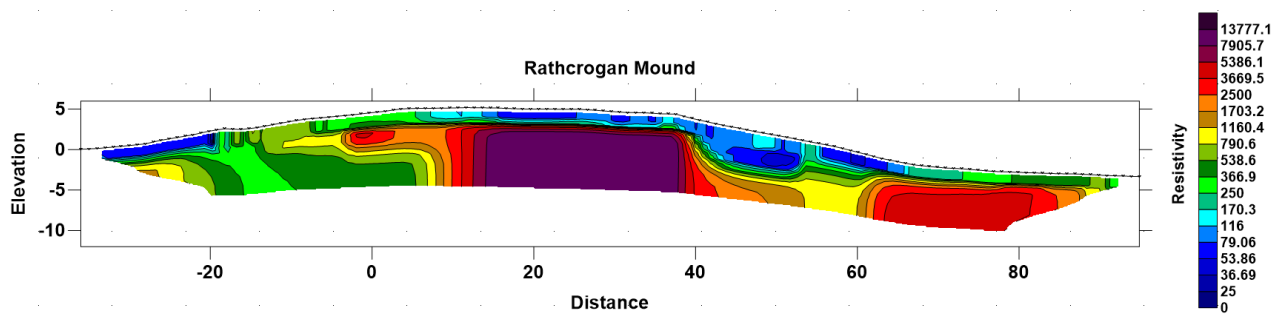

Figure 50. Plot of the RATCHRO.INV file output using Surfer.

Appendix F Depth of investigation (DOI) calculations

The DOI method (Oldenburg and Li 1999) attempts to assess the parts of the inverse model that are well constrained by the data. The least-squares optimization equation is modified to the following form (see section 11.2.5),

$$\left(\mathbf{J}^T \mathbf{J} + \lambda(\mathbf{F} + \mu \mathbf{I})\right) \Delta \mathbf{q}_k = \mathbf{J}^T \mathbf{g} - \lambda \mathbf{F} \mathbf{q}_k - \lambda \mu (\mathbf{q}_k - \mathbf{q}_m).$$

The reference model \mathbf{q}_m is usually a homogenous model with the average apparent resistivity value. In the DOI method, two inversions are carried out with difference reference models, such as with one-tenth and ten times the average apparent resistivity values. From the model resistivity values, the following depth of investigation (DOI) index is calculated.

$$R(x, z) = \frac{q_1(x, z) - q_2(x, z)}{q_{m1} - q_{m2}} \quad (\text{F.1})$$

q_{m1} and q_{m2} are the resistivity of first and second reference models, $q_1(x, z)$ and $q_2(x, z)$ are model cell resistivity obtained from the first and second inversions. R will approach a value of 0.0 where the inversion will produce the same cell resistivity regardless of the reference model resistivity in areas that are well constrained by the data. In areas where the data do not have much information about the cell resistivity, R will approach a value of 1.0 as the cell resistivity will be similar to the reference resistivity. Thus, the model resistivity in areas where R has small values is considered to be “reliable”, while in areas with high R values are not reliable.

The model used to calculate the DOI index use cells that extend to the ends of the survey line, and a depth range of about three to five times the maximum median depth of investigation of the arrays in the data set. This ensures that data has minimal information about the resistivity of the cells near the bottom of the model, i.e. in theory the bottom cells have DOI values of almost 1.0. However, if the model does not extend sufficiently far downwards or the reference damping factor μ is too small, the maximum DOI value might be much less than 1.0. In such cases, the ‘normalized’ DOI value (R_n) can be used. It is given by

$$R_n = \frac{R}{R_{\max}},$$

where R_{\max} can be the maximum DOI value. Some model sections might have small local artifacts that might result in irregular DOI contours. The ‘Smoothed normalized DOI’ display takes a weighted average of the DOI value for a particular model cell with the DOI values for the neighboring cells around it. An example of this plot is shown in Figure 51.

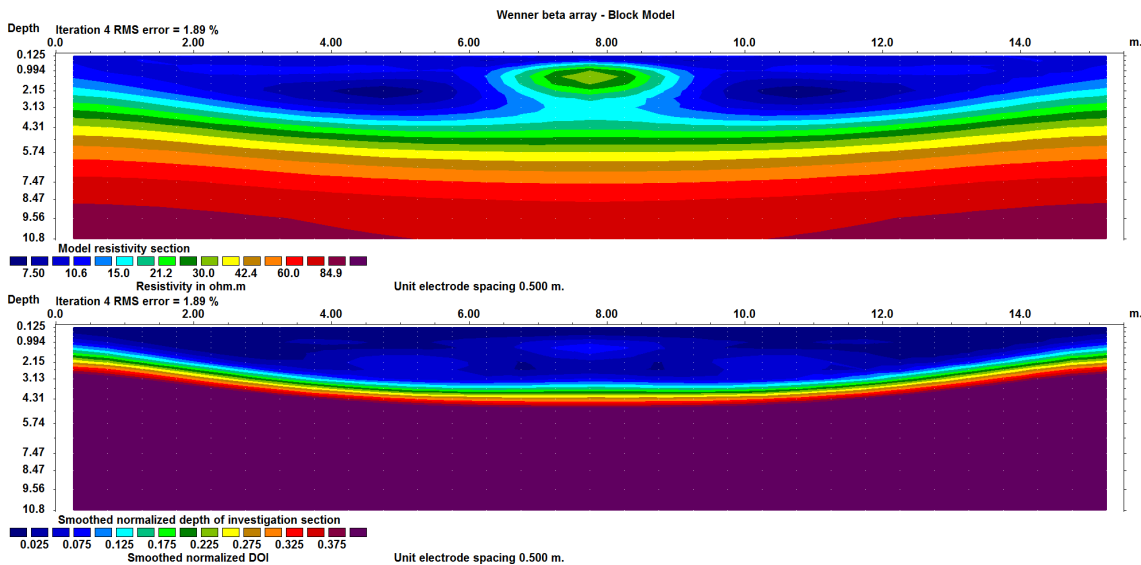

Figure 51. Example DOI plot for the beta.dat file. The top section shows the inverse resistivity model where the second reference model was used. As such, the inverse model values tend to be higher towards the bottom of the section as it trends to the reference resistivity used. The second section is the DOI section plot. If a DOI contour value of 0.1 is used as the cutoff point, the maximum depth of investigation in the middle of the survey line is about 3.5 meters. This DOI contour line becomes gradually shallower towards the ends of the line where there is less data.

DISCLAIMER

This software is provided "as is" without any express or implied warranties including its suitability for a particular purpose. Neither this company nor the subagent will assume responsibility for any damage or loss caused by the use of this program. In the event of program bugs, every effort will be made to correct the bugs. Registered users are entitled to free software updates and support for the first year. After the first year, there is an annual fee for software updates and technical support. However, the original software version provided and downloaded updates released up to one year after the software purchase can still be used indefinitely if the user chooses not to upgrade. Please contact Geotomo Software Sdn Bhd (geotomosoft@outlook.com or sales@aarhusgeosoftware.dk) or refer to the 'Ordering & Enquires' page on the www.geotomosoft.com website, for the annual fee that is applicable to your license.

SUPPORT

Please contact your distributor if you have any questions concerning this program. A frequent source of queries is when the results obtained are not what you expect, or the program refuses to accept your data file. In such a case, support will only be provided if a copy of the data file is sent together as an attachment with your email, preferably compressed into a ZIP file. The most common causes of problems are (a) the data in the DAT file is not given in the correct RES2DINV format (b) excessive noise in the data set (particularly for dipole-dipole surveys and/or IP data sets) (c) instrument malfunction or field survey errors. It is only possible to trace the source of the problem if a copy of the data file is provided. Please note that support is only available for registered users of the full version of the program. It is not possible to provide technical support for users of the demo version of this software. For technical support, you can contact the software provider by email at the following addresses. Please attach a copy of your data file to your email.

geotomosoft@gmail.com, support@aarhusgeosoftware.dk

The following information will be required before technical support is provided.

- 1). Your license number. This ID number is displayed near the middle of the initial information box when the RES2DINV program starts up if the program has a valid license.
- 2). The name of your company or institution.
- 3). Approximate date your company/institution purchased the software.

If you purchased the software more than one year ago, please contact Geotomo Software Sdn Bhd (sales@aarhusgeosoftware.dk) on renewing the support.

What's New

Version 3.00 - Major upgrade to Windows 3.1 and 95. Maximum number of electrodes increased to 500. Multi-tasking support for Windows 95. Support for any Windows compatible graphics card and printer.

Version 3.01 - Improvements to finite-difference subroutine to calculate the Jacobian matrix which is now about twice as fast as the earlier versions.

Version 3.10 - Support for underwater surveys. Direct incorporation of topography into inversion model using a distorted finite-element grid.

Version 3.11 - The time taken by the finite-element subroutine to calculate the Jacobian matrix is reduced. An option to use a finer mesh for the finite-difference or finite-element forward modelling method is added.

Version 3.12 - Non-integer values for the “*n*” factor for the dipole-dipole, pole-dipole and Wenner-Schlumberger arrays supported (please refer to Appendix A). The maximum limits for the number of data levels and model layers increased to 52 and 17 respectively.

Version 3.13 - The ratio of the largest electrode spacing to unit electrode spacing for the Wenner and pole-pole array was increased from 32 to 64. The maximum number of data levels is now 64. The maximum number of model layers was also increased to 18.

Version 3.20 - Support for IP data added.

Version 3.21 - The maximum number of electrodes was increased to 650. Improvements has been made to the disk-memory swapping subroutines so that for a given amount of RAM the number of datum points the program can handle is increased. For computer systems with more than one hard-disk drive, the program will automatically select the drive with the most free disk space to store the temporary disk swap files.

Version 3.22 - Slight improvements to the use of memory in the IP inversion section. The size of the IP data set that can be handled for a given amount of memory was increased. An option to optimise the damping factor automatically during the inversion process was added. Support for the “reverse” pole-dipole array added (see Appendix A). Support for a command line batch mode included (see Appendix I). An option to plot the model section in the form of rectangular blocks was also added.

Version 3.30 - Support for cross-borehole surveys added. An option to allow the number of model parameters to exceed the number of datum points was also added.

Version 3.31 - An option for a used defined model added. In this model, the user specifies the thickness of the first layer and the factor to increase the thickness for each subsequent deeper layer. The program will also automatically update the directory used for the input data files and the output inversion files listed in the RES2DINV.INI file.

Version 3.32 - An option to extend the subdivision of the subsurface into blocks to the edges of the survey line was added. Option to display the uncertainty in the model resistivity values was also added.

Version 3.33 - An option to incorporate the effects of the remote electrodes used in surface resistivity surveys with the pole-pole and pole-dipole arrays was added.

Version 3.34 - A few bug fixes. The user can now scale the depths of the model layers so that the depth to the last layer can be much greater than the default limit allowed by the program. When the program saves the model values in the XYZ format, it will now also save the coordinates of the corners of the blocks in the model. An option to use a very fine mesh in the vertical direction for resistivity contrasts of greater than 250:1 was added, as well as an option for 6 nodes in the horizontal direction between adjacent electrodes.

Version 3.35 - The user can now set the maximum number of electrodes, from 150 to 1500, via the JACOBWIN.EXE program. Drawing of colour contour sections is now significantly faster on most computers.

Version 3.36 - A robust least-squares inversion option was added. For very noisy data with 'outliers', the resulting model will be less sensitive to such datum points when the robust data inversion method is selected. For areas where the subsurface geology has sharp interfaces, the robust model inversion method will give better results.

Version 3.40 - Support for non-conventional arrays for resistivity surveys.

Version 3.41 – Two new methods for topographic modelling using a damped distorted grid and the inverse Schwartz-Christoffel transformation added.

Version 3.42 - Support for remote electrodes for IP surveys.

Version 3.43 - Support for the Wenner Gamma array, and underwater surveys with non-conventional arrays. Maximum number of electrodes increased to 2000. The program has also been optimised for data sets where the unit electrode spacing has been reduced by half of the actual value so as to get a model where the width of the blocks is half the usual size. This helps in cases where there are very large lateral resistivity variations near the surface.

Version 3.44 - Support for IP surveys with non-conventional arrays. This feature is useful in some cases where data from a series of overlapping collinear 1D sounding survey lines can be combined into a single 2-D data set to obtain a 2-D model.

Version 3.45 - Option to save results in SURFER format added. Also support for surveys with some electrodes underwater and some electrodes above the water surface level added.

Version 3.46 - Minor additions for data in general array format. Option to use a model with half the unit electrode spacing for data in general array format is added (see the file RATCMIX2.DAT for an example). It is now possible to carry out the inversion of data in the general array format with the demo version, but the results will only be displayed temporarily on the screen during the inversion. The damped distorted grid finite-element method is set as the default method for topographic modelling.

Version 3.47 – An option to carry out the inversion of IP data sequentially was added. Slight changes in the menu structure.

Version 3.48 – Support for up to 4 boreholes in cross-borehole option.

Version 3.49 – Incomplete Gauss-Newton inversion option added. Maximum number of electrodes increased to 4000, and maximum number of data points to 20000. Option to combine a number of 2-D data files in RES2DINV format into a single 3-D data file in RES3DINV format added.

Version 3.50 – Bedrock edge detection and time-lapse options added.

Version 3.51 – Option to include data noise estimates included.

Version 3.52 – Option for surveys with floating electrodes added. Support for topography in cross-borehole surveys included.

Version 3.53 – Sparse inversion option for very long survey lines (2000 to 16000 electrode positions) added. This method inverts the entire data set and model at a single time to produce a continuous and seamless model. New format for batch mode option script file which makes use of the files containing the inversion parameters produced by the RES2DINV program.

Version 3.54 – Option to include boundaries of layers from seismic or borehole surveys added.

Version 3.55 – Support for the multiple gradient array added.

Version 3.56 – Support for the offset pole-dipole array added.

Version 3.57 – Support to incorporate water layer into the inversion model for surveys with floating electrodes added.

Version 3.58 – Support for global coordinates added.

Version 3.59 – Support for time-lapse cross-borehole data added. Support for inclined boreholes added.

Version 3.70 Beta - Trial version with support for multi-core PCs. New inversion algorithm for time-lapse data. Complex resistivity inversion method for I.P. data.

Version 3.71 - Option to calculate model resolution values. New time-lapse method support for cross-borehole data.

Version 4.00 - 64-bit version that can access more than 4 GB RAM. This greatly increases the maximum size of the data set and model that can be handled. Supports up to 30 time series for time-lapse surveys.

Version 4.01 – Options to extend the horizontal range of inversion model and fast calculation of Jacobian matrix for dense data sets added.

Version 4.02 – Option to collate data from 2-D lines that are not parallel or orthogonal in the Res3dinvx64 arbitrary electrodes format. Option for using L-curve method to estimate optimum damping factor added.

Version 4.03 – Support for more than one water layer for underwater surveys added.

Version 4.04 – Support for survey with electrodes on the ground surface and water bottom across water layer with a limited extent (such as a dam) added. Support for time-lapse I.P. data.

Version 4.05 – Support for underwater surveys with electrodes on a streamer suspended in the water layer with the entire water layer modeled by the finite-element mesh. Option to fix resistivity of regions above and below sharp boundary added.

Version 4.06 – Depth of investigation (DOI) calculations added. Option to display sequential changes in time-lapse display.

Version 4.07 – Options to display correlation plots for the data misfits added. Support for BMP, JPEG, PNG, TIFF and GIF bitmap graphics file formats.

Version 4.08 – Option to remove a series of data points using the ‘Exterminate bad data points’ option by using mouse right click the first and last data point in a profile. Model with borehole electrodes saved to xyz file with global coordinates if present. Option to save output model in Paraview vtk format. I.P. model values automatically saved with resistivity values and a second vtk file is automatically generated if global coordinates present. Aarhus Geosoftware online copy protection system implemented to replace USB dongle system.